



**HAL**  
open science

## Variants associated with Gaucher disease in multiple system atrophy

Jun Mitsui, Takashi Matsukawa, Hidenao Sasaki, Ichiro Yabe, Masaaki Matsushima, Alexandra Dürr, Alexis Brice, Hiroshi Takashima, Akio Kikuchi, Masashi Aoki, et al.

► **To cite this version:**

Jun Mitsui, Takashi Matsukawa, Hidenao Sasaki, Ichiro Yabe, Masaaki Matsushima, et al.. Variants associated with Gaucher disease in multiple system atrophy. *Annals of Clinical and Translational Neurology*, 2015, 2 (4), pp.417-426 10.1002/acn3.185 . hal-01122349

**HAL Id: hal-01122349**

**<https://hal.sorbonne-universite.fr/hal-01122349>**

Submitted on 3 Mar 2015

**HAL** is a multi-disciplinary open access archive for the deposit and dissemination of scientific research documents, whether they are published or not. The documents may come from teaching and research institutions in France or abroad, or from public or private research centers.

L'archive ouverte pluridisciplinaire **HAL**, est destinée au dépôt et à la diffusion de documents scientifiques de niveau recherche, publiés ou non, émanant des établissements d'enseignement et de recherche français ou étrangers, des laboratoires publics ou privés.



Distributed under a Creative Commons Attribution - NonCommercial - NoDerivatives 4.0 International License

## RESEARCH ARTICLES

**Variants associated with Gaucher disease in multiple system atrophy**

Jun Mitsui<sup>1</sup>, Takashi Matsukawa<sup>1</sup>, Hidenao Sasaki<sup>2</sup>, Ichiro Yabe<sup>2</sup>, Masaaki Matsushima<sup>2</sup>, Alexandra Dürr<sup>3</sup>, Alexis Brice<sup>3</sup>, Hiroshi Takashima<sup>4</sup>, Akio Kikuchi<sup>5</sup>, Masashi Aoki<sup>5</sup>, Hiroyuki Ishiura<sup>1</sup>, Tsutomu Yasuda<sup>1</sup>, Hidetoshi Date<sup>1</sup>, Budrul Ahsan<sup>1</sup>, Atsushi Iwata<sup>1</sup>, Jun Goto<sup>1</sup>, Yaeko Ichikawa<sup>1</sup>, Yasuo Nakahara<sup>1</sup>, Yoshio Momose<sup>1</sup>, Yuji Takahashi<sup>1</sup>, Kenju Hara<sup>6</sup>, Akiyoshi Kakita<sup>7</sup>, Mitsunori Yamada<sup>7,8</sup>, Hitoshi Takahashi<sup>7</sup>, Osamu Onodera<sup>6</sup>, Masatoyo Nishizawa<sup>6</sup>, Hirohisa Watanabe<sup>9</sup>, Mizuki Ito<sup>9</sup>, Gen Sobue<sup>9</sup>, Kinya Ishikawa<sup>10</sup>, Hidehiro Mizusawa<sup>10</sup>, Kazuaki Kanai<sup>11</sup>, Takamichi Hattori<sup>11</sup>, Satoshi Kuwabara<sup>11</sup>, Kimihito Arai<sup>12</sup>, Shigeru Koyano<sup>13</sup>, Yoshiyuki Kuroiwa<sup>14</sup>, Kazuko Hasegawa<sup>15</sup>, Tatsuhiro Yuasa<sup>16</sup>, Kenichi Yasui<sup>17</sup>, Kenji Nakashima<sup>17</sup>, Hijiri Ito<sup>18</sup>, Yuishin Izumi<sup>19</sup>, Ryuji Kaji<sup>19</sup>, Takeo Kato<sup>20</sup>, Susumu Kusunoki<sup>21</sup>, Yasushi Osaki<sup>22</sup>, Masahiro Horiuchi<sup>23</sup>, Tomoyoshi Kondo<sup>24</sup>, Shigeo Murayama<sup>25</sup>, Nobutaka Hattori<sup>26</sup>, Mitsutoshi Yamamoto<sup>27</sup>, Miho Murata<sup>28</sup>, Wataru Satake<sup>29</sup>, Tatsushi Toda<sup>29</sup>, Alessandro Filla<sup>30</sup>, Thomas Klockgether<sup>31</sup>, Ullrich Wüllner<sup>31</sup>, Garth Nicholson<sup>32</sup>, Sid Gilman<sup>33</sup>, Caroline M. Tanner<sup>34</sup>, Walter A. Kukull<sup>35</sup>, Mathew B. Stern<sup>36</sup>, Virginia M.-Y. Lee<sup>37</sup>, John Q. Trojanowski<sup>37</sup>, Eliezer Masliah<sup>38</sup>, Phillip A. Low<sup>39</sup>, Paola Sandroni<sup>39</sup>, Laurie J. Ozelius<sup>40</sup>, Tatiana Foroud<sup>41</sup> & Shoji Tsuji<sup>1</sup>

<sup>1</sup>Department of Neurology, Graduate School of Medicine, University of Tokyo, Tokyo, Japan

<sup>2</sup>Department of Neurology, Hokkaido University Graduate School of Medicine, Sapporo, Japan

<sup>3</sup>AP-HP, Hôpital de la Salpêtrière, Département de Génétique et Cytogénétique, Inserm, U 1127, Cnrs, UMR 7225, 3- Sorbonne Université, UPMC Univ Paris 06, UM 75, ICM, F-75013, Paris, France

<sup>4</sup>Department of Neurology and Geriatrics, Kagoshima University Graduate School of Medical and Dental Sciences, Kagoshima, Japan

<sup>5</sup>Department of Neurology, Tohoku University School of Medicine, Sendai, Japan

<sup>6</sup>Department of Neurology, Brain Research Institute, Niigata University, Niigata, Japan

<sup>7</sup>Department of Pathology, Brain Research Institute, Niigata University, Niigata, Japan

<sup>8</sup>Department of Clinical Research, Saigata Medical Center, National Hospital Organization, Niigata, Japan

<sup>9</sup>Department of Neurology, Nagoya University Graduate School of Medicine, Nagoya, Japan

<sup>10</sup>Department of Neurology and Neurological Science, Graduate School of Medical and Dental Science, Tokyo Medical and Dental University, Tokyo, Japan

<sup>11</sup>Department of Neurology, Chiba University School of Medicine, Chiba, Japan

<sup>12</sup>Division of Neurology, National Hospital Organization, Chiba East Hospital, Chiba, Japan

<sup>13</sup>Department of Clinical Neurology and Stroke Medicine, Graduate School of Medicine, Yokohama City University, Yokohama, Japan

<sup>14</sup>Department of Neurology, Teikyo University School of Medicine University Hospital, Mizonokuchi, Kawasaki, Japan

<sup>15</sup>Division of Neurology, National Hospital Organization, Sagami National Hospital, Sagami, Japan

<sup>16</sup>Department of Neurology, Kamagaya-Chiba Medical Center for Intractable Neurological Disease, Kamagaya General Hospital, Chiba, Japan

<sup>17</sup>Division of Neurology, Department of Brain and Neurosciences, Faculty of Medicine, Tottori University, Yonago, Japan

<sup>18</sup>Department of Neurology, Mifukai Vihara Hananosato Hospital, Hiroshima, Japan

<sup>19</sup>Department of Clinical Neuroscience, Institute of Health Biosciences, University of Tokushima Graduate School, Tokushima, Japan

<sup>20</sup>Departments of Neurology, Hematology, Metabolism, Endocrinology, and Diabetology, Faculty of Medicine, Yamagata University, Yamagata, Japan

<sup>21</sup>Department of Neurology, Kinki University School of Medicine, Osaka, Japan

<sup>22</sup>Department of Geriatrics, Cardiology and Neurology, Kochi Medical School, Nankoku, Japan

<sup>23</sup>Division of Neurology, Department of Internal Medicine, St. Marianna University School of Medicine, Kawasaki, Japan

<sup>24</sup>Department of Neurology, Wakayama Medical University, Wakayama, Japan

<sup>25</sup>Department of Neuropathology and the Brain Bank for Aging Research, Tokyo Metropolitan Geriatric Hospital and Institute of Gerontology, Tokyo, Japan

<sup>26</sup>Department of Neurology, Juntendo University School of Medicine, Tokyo, Japan

<sup>27</sup>Department of Neurology, Kagawa Prefectural Central Hospital, Takamatsu, Japan

<sup>28</sup>Department of Neurology, National Center Hospital of Neurology and Psychiatry, Tokyo, Japan

<sup>29</sup>Division of Neurology/Molecular Brain Science, Kobe University Graduate School of Medicine, Kobe, Japan

<sup>30</sup>Department of Neurological Sciences, University Federico II, Naples, Italy

<sup>31</sup>Department of Neurology, University of Bonn and German Center for Neurodegenerative Diseases (DZNE), Bonn, Germany

<sup>32</sup>Concord Hospital, University of Sydney at the Australian and New Zealand Army Corps (ANZAC) Research Institute, Sydney, Australia

<sup>33</sup>Department of Neurology, University of Michigan, Ann Arbor, Michigan

<sup>34</sup>Parkinson's Disease Research Education and Clinical Center, San Francisco Veteran's Affairs Medical Center, San Francisco, California

<sup>35</sup>Department of Epidemiology, University of Washington School of Public Health, Seattle, Washington

<sup>36</sup>Parkinson's Disease and Movement Disorders Center, Department of Neurology, Perelman School of Medicine at the University of Pennsylvania, Philadelphia, Pennsylvania

<sup>37</sup>Institute on Aging, Udall Parkinson's Research Center, Center for Neurodegenerative Disease Research and the Department of Pathology and Laboratory Medicine, Perelman School of Medicine at the University of Pennsylvania, Philadelphia, Pennsylvania

<sup>38</sup>Department of Neurosciences, University of California San Diego, San Diego, California

<sup>39</sup>Department of Neurology, Mayo Clinic, Rochester, Minnesota

<sup>40</sup>Departments of Genetics and Genomic Sciences and Neurology, Icahn School of Medicine at Mount Sinai, New York, New York

<sup>41</sup>Department of Medical and Molecular Genetics, Indiana University School of Medicine, Indianapolis, Indiana

## Correspondence

Shoji Tsuji, 7-3-1 Hongo, Bunkyo, Tokyo  
113-8655, Japan. Tel: +81-3-5800-8972;  
Fax: +81-3-5800-6548;  
E-mail: tsuji@m.u-tokyo.ac.jp

## Funding Information

This study was supported in part by KAKENHI (Grant-in-Aid for Scientific Research on Innovative Areas [22129001 and 22129002]) to S. T.; the Global COE Program from the Ministry of Education, Culture, Sports, Science and Technology of Japan, a Grant-in-Aid (H23-Jitsuyoka [Nanbyo]-Ippan-004, and "the Research Committee for Ataxic Diseases" of the Research on Measures for Intractable Diseases) from the Ministry of Health, Welfare and Labour, Japan to S. T.; the French Agency for Research (ANR-09-MNPS-032-01/R09148DS) and the Programme Hospitalier de Recherche Clinique (AOM03059/R05129DD) to A. D. and A. B.; the Deutsche Forschungsgemeinschaft (Wu 184-6) the Deutsche Parkinson Vereinigung to U. W.; National Institutes of Health grant (NS-53488) to J. Q. T.; and National Institutes of Health grant (P01NS044233) to P. A. L.

Received: 12 January 2015; Revised: 28 January 2015; Accepted: 28 January 2015

doi: 10.1002/acn3.185

## Introduction

Multiple system atrophy (MSA) is a progressive neurodegenerative disease characterized clinically by autonomic failure in addition to various combinations of parkinsonism, cerebellar ataxia, and pyramidal dysfunction.<sup>1</sup> The cardinal neuropathological hallmark is argyrophilic filamentous glial cytoplasmic inclusions (GCIs)<sup>2,3</sup> in which fibrillar aggregates of  $\alpha$ -synuclein in oligodendrocytes are the major components.<sup>4,5</sup>

## Abstract

**Objective:** Glucocerebrosidase gene (*GBA*) variants that cause Gaucher disease are associated with Parkinson disease (PD) and dementia with Lewy bodies (DLB). To investigate the role of *GBA* variants in multiple system atrophy (MSA), we analyzed *GBA* variants in a large case-control series. **Methods:** We sequenced coding regions and flanking splice sites of *GBA* in 969 MSA patients (574 Japanese, 223 European, and 172 North American) and 1509 control subjects (900 Japanese, 315 European, and 294 North American). We focused solely on Gaucher-disease-causing *GBA* variants. **Results:** In the Japanese series, we found nine carriers among the MSA patients (1.65%) and eight carriers among the control subjects (0.89%). In the European series, we found three carriers among the MSA patients (1.35%) and two carriers among the control subjects (0.63%). In the North American series, we found five carriers among the MSA patients (2.91%) and one carrier among the control subjects (0.34%). Subjecting each series to a Mantel-Haenszel analysis yielded a pooled odds ratio (OR) of 2.44 (95% confidence interval [CI], 1.14–5.21) and a *P*-value of 0.029 without evidence of significant heterogeneity. Logistic regression analysis yielded similar results, with an adjusted OR of 2.43 (95% CI 1.15–5.37) and a *P*-value of 0.022. Subtype analysis showed that Gaucher-disease-causing *GBA* variants are significantly associated with MSA cerebellar subtype (MSA-C) patients ( $P = 7.3 \times 10^{-3}$ ). **Interpretation:** The findings indicate that, as in PD and DLB, Gaucher-disease-causing *GBA* variants are associated with MSA.

Until recently, MSA had been defined as a nongenetic disorder, but then several multiplex families with the disease were described, triggering extensive fruitful searches for susceptibility genes in case-control association studies.<sup>6,7</sup> Subsequently, we identified a homozygous mutation and compound heterozygous mutations of *COQ2* in two multiplex families with MSA.<sup>8</sup> We also found a common variant (V393A) and multiple rare variants in *COQ2*, all of which lead to functional impairments in the *COQ2* gene product that increase the risk of developing sporadic MSA.

V393A was observed exclusively in the Japanese population, and the carrier frequency of V393A was significantly higher in Japanese MSA patients (9.1%) than in Japanese controls (3.3–4.4%) with odds ratios of 2.1–3.0. These findings suggest that impaired COQ2 activity, which would be predicted to impair the mitochondrial respiratory chain and increase vulnerability to oxidative stress, causes susceptibility to MSA. As the association was observed only in a small proportion of MSA patients, the pathogenic mechanisms underlying MSA largely remain unknown.

In contrast to the GCIs found in MSA, neuronal inclusions containing  $\alpha$ -synuclein, termed Lewy bodies (LBs), are observed neuropathologically in Parkinson disease (PD) and dementia with LBs (DLB).<sup>9</sup> Abnormal fibrillar  $\alpha$ -synuclein aggregation in LBs and GCIs is the common feature of PD/DLB and MSA, respectively, which collectively form a subset of neurodegenerative disorders referred to as the “ $\alpha$ -synucleinopathies”.<sup>10</sup> Intriguingly, a link between PD and MSA was reported recently based on postmortem brain examinations of familial PD patients with SNCA mutations (G51D and A53E) showing  $\alpha$ -synuclein pathology characterized by neuronal and oligodendroglial inclusions similar to GCIs.<sup>11,12</sup> Moreover, the risk of parkinsonism among first-degree relatives is significantly higher in MSA patients than in control subjects,<sup>13,14</sup> and coincidence of PD and MSA within the same pedigrees has been reported.<sup>15</sup> Taken together, these findings raise the possibility that MSA and PD share some genetic basis.

Glucocerebrosidase (*GBA*) genetic variants that have been proven to be pathogenic for Gaucher disease (GD variants) are strongly associated with PD and DLB.<sup>16–18</sup> Initial focus upon GD variants came from a report of several families of patients with GD in which obligate or confirmed carriers frequently developed parkinsonism.<sup>19</sup> As then, many studies have shown that GD variants are associated with PD and DLB.<sup>16–18</sup>

In this study, we analyzed *GBA* in a large series of sporadic MSA patients and control subjects to investigate the role of GD variants in the pathogenesis of MSA.

## Methods

### Patients with sporadic MSA and control subjects

All patients with sporadic MSA and healthy control subjects described in the previous reports,<sup>8,16</sup> and additional participants (210 MSA patients and 380 control subjects in the Japanese series) were enrolled in this study. Written informed consent was obtained from all participants in accordance with research protocols that were approved by institutional review boards at participating centers. The diagnoses of possible and probable MSA were made

based upon current consensus criteria.<sup>1</sup> A total of 574 patients with sporadic MSA and 900 control subjects were included in the Japanese series, 223 patients and 315 control subjects in the European series and 172 patients and 294 control subjects in the North American series (persons of European or Hispanic descent living in North America). Ancestry was determined by self-report on a multiple-choice questionnaire. The North American series comprised 160 persons of European descent and 12 persons of Hispanic descent in patients and 284 persons of European descent and 10 persons of Hispanic descent in control subjects. Among the 218 MSA patients in the Japanese series where information on family history was available (159 with MSA cerebellar subtype [MSA-C], 53 with MSA of the parkinsonism subtype [MSA-P] and six with MSA of undefined subtype), there were 22 MSA patients (11 MSA-C, 10 MSA-P, and one undefined subtype) who also had relatives with the clinical diagnosis of PD. Among these relatives with PD, genomic DNAs were available from five (in five families) who had siblings with MSA. Sporadic MSA patients and control subjects were recruited without reference to the presence of family history for parkinsonism. Demographic characteristics are shown in Table 1. In the European series, the male to female ratio was significantly higher in cases than in controls ( $P = 0.0012$ ). In the Japanese series, the mean age at examination was significantly older in cases than that in controls ( $P < 0.0001$ ). The MSA-P to MSA-C ratio was significantly higher in the North American series than that in the Japanese series and the European series ( $P < 0.0001$  and  $P < 0.0001$ , respectively).

### Multiplex families with MSA

Independent of the sporadic case–control series, six previously described multiplex Japanese families (1–4, 8, and 12: same families with those in a previous report)<sup>8</sup> were also screened for *GBA* variants. Autopsy findings of two affected members in Family 1 and III-6 in Family 8 confirmed the diagnosis of MSA. As previously reported, affected members in Family 1 carried the homozygous M128V-V393A variant in *COQ2* and those in Family 12 carried the compound heterozygous R387X/V393A variants in *COQ2*.<sup>8</sup>

### Nucleotide sequence analysis of GBA

Polymerase chain reaction products were subjected to direct nucleotide sequence analysis of coding sequences and flanking splice sites of *GBA* with a DNA analyzer, 3730xl (Life Technologies, Carlsbad, CA). Three primer pairs were designed selectively to amplify *GBA* but not its pseudogene, as previously described.<sup>16,20</sup> Analysis of sequence traces was achieved using Variant Reporter v1.1

**Table 1.** Demographic data of participants.

	Japanese series		European series		North American series	
	MSA patients	Control subjects	MSA patients	Control subjects	MSA patients	Control subjects
<i>N</i>	574	900	223	315	172	294
Age at onset	58.7, 8.7	NA	55.4, 8.3	NA	58.4, 9.5	NA
Age at examination	62.8, 8.3	51.1, 16.7	59.2, 8.0	58.9, 6.1	ND	65.2, 9.0
Sex (male/female)	306/268	434/466	138/85	150/165	103/69	156/138
Clinical subtype (MSA-C/MSA-P/Undefined)	403/141/30	NA	191/22/10	NA	52/107/13	NA

Values are presented as means and standard deviations. NA, not applicable; ND, not described; MSA-C, multiple system atrophy cerebellar subtype; MSA-P, multiple system atrophy parkinsonism subtype.

(Life Technologies) and by manual inspection of electro-pherograms. All sequencing analysis was performed at the Medical Genome Center, The University of Tokyo Hospital.

### Nomenclature of GBA variants

Amino acid numbering of *GBA* variants followed conventional nomenclature, which considers the first amino acid after the signal peptide (the first amino acid of the mature *GBA* protein) as amino acid 1.<sup>21</sup>

### Gaucher-disease-causing GBA variants

We referred to the Human Gene Mutation Database (HGMD) Professional 2014.1 (BIOBASE, Beverly, MA) for information about *GBA* variants. The variants that were categorized as “disease-causing mutations” for GD in HGMD are hereinafter termed GD variants. In this study, we focused solely on GD variants, which included 256 missense variants, 19 splicing variants, 28 small deletions, 15 small insertions, four small indels, four gross deletions (defined as more than 20 base-pairs), one gross insertion, and 18 complex rearrangements.

### Statistical analysis

Results are presented as means and standard deviations. We used Student’s *t*-test to determine whether the mean age at disease onset between carriers and noncarriers of the GD variants were significantly different. We used Fisher’s exact test and multiple logistic regression analysis to calculate the significance of differences in allele frequencies. We used multiple logistic regression analysis to compute odds ratios and corresponding 95% confidence intervals (CIs). We calculated pooled odds ratios based on a fixed-effects model (Mantel–Haenszel method) and a multiple logistic regression model. The heterogeneity across odds ratios was assessed with Cochran *Q* statistic, Breslow-Day test, and  $I^2$  statistics. All statistical tests were

two-sided, and we used a *P*-value of less than 0.05 to indicate statistical significance. Our statistical analysis utilized StatsDirect version 2.7.8 (StatsDirect, Cheshire, England) and R version 2.15.3 (<http://r-project.org/>).

### Results

We identified 20 nonsynonymous single-nucleotide substitutions and one complex multiple-nucleotide substitutions (L444P-A456P-V460V or *RecNciI*) in our sporadic case-control series. Among these 21 variants, nine were known GD variants (R120W, G202R, F213I, N370S, G377S, D409H, L444P, L444R, and *RecNciI*) (Table 2), that is, all nine have been proven to be pathogenic for GD, which were identified only in cases with clinical features of GD and decreased *GBA* activities.<sup>22–29</sup> The other 12 variants have not been reported to be pathogenic for GD, and include I(-20)V, P55L, Q57R, L67Q, R163Q, I204M, E326K, T334I, F347L, T369M, T410R, and I489V (Table S1). Of note, it has been shown that activities of mutant *GBA* with E326K are slightly to moderately decreased. The consensus is that E326K is not sufficient to cause GD, and a functional polymorphism.<sup>30</sup> With these considerations, we did not include E326K as GD-causing mutations.

In the Japanese series, we found nine carriers of GD variants among 574 MSA patients (1.65%) and eight carriers among 900 control subjects (0.89%). In the European series, we found three carriers among 223 MSA patients (1.35%) and two carriers among 315 control subjects (0.63%). In the North American series, we found five carriers among 172 MSA patients (2.91%) and one carrier among 294 control subjects (0.34%). Combining all series, we identified 17 carriers among 969 MSA patients (1.75%) as GD variant carriers, and we found GD variant carriers in 11 of the 1509 control subjects (0.73%). Among carriers of GD variants, two MSA patients (one MSA-C from the European series and one MSA-P from the North American series) carried homozygous N370S variants, whereas none of the control subjects had two alleles with GD variants. The ages at onset of the



**Table 2.** Gaucher-disease-causing *GBA* variants in sporadic MSA patients and control subjects in each series.

Genotypes	Japanese series		European series		North American series	
	MSA patients (n = 574)	Control subjects (n = 900)	MSA patients (n = 223)	Control subjects (n = 315)	MSA patients (n = 172)	Control subjects (n = 294)
R120W/NM	1	0	0	0	0	0
G202R/NM	1	0	0	0	0	0
F213I/NM	2	0	0	0	0	1
N370S/NM	0	0	1	2	2	0
N370S/N370S	0	0	1	0	1	0
G377S/NM	0	0	0	0	1	0
D409H/NM	0	1	0	0	0	0
L444P/NM	4	2	1	0	1	0
L444R/NM	1	0	0	0	0	0
RecNci/NM	0	5	0	0	0	0
Total	9/574 (1.65%)	8/900 (0.89%)	3/223 (1.35%)	2/315 (0.63%)	5/172 (2.91%)	1/294 (0.34%)
Odds ratio (95% confidence interval)	1.78 (0.68–4.76)		2.13 (0.35–16.3)		8.77 (1.34–168.8)	
Fisher's exact test	<i>P</i> = 0.32		<i>P</i> = 0.65		<i>P</i> = 0.028	

Logistic regression analysis	MSA patients (n = 969)	Control subjects (n = 1509)
Carrier frequency of Gaucher-disease-causing <i>GBA</i> variants	17/969 (1.75%)	11/1509 (0.73%)
Odds ratio adjusted for each series (95% confidence interval)	2.43 (1.15–5.37), <i>P</i> = 0.022	
Odds ratio unadjusted for each series (95% confidence interval)	2.43 (1.15–5.37), <i>P</i> = 0.022	

GBA, Glucocerebrosidase; MSA, multiple system atrophy; NM, nonmutated allele.

MSA-C and MSA-P patients were 43 and 69, respectively. The available medical records of the two cases made no mention of GD or relevant clinical signs.

Although the carrier frequencies of GD variants were higher in MSA patients than in control subjects within the three series, the difference was significant only in the North American series (*P* = 0.028). A Mantel–Haenszel procedure of each series yielded a pooled odds ratio (OR) of 2.44 (95% CI 1.14–5.21) and a *P*-value of 0.029 (Fig. 1). The heterogeneity of OR of each series from the Mantel–Haenszel analysis was not significant (Cochran *Q* = 1.80, *P* = 0.41; Breslow–Day = 1.99, *P* = 0.37; *I*<sup>2</sup> = 0%). A multiple logistic regression model employing GD variants in each series yielded an OR adjusted for each series of 2.43 (95% CI = 1.15–5.37, *P* = 0.022), and an unadjusted OR of 2.43 (95% CI = 1.15–5.37, *P* = 0.022) (Table 2). Taken together, these data indicate that there is no effect modification by the series.

We then analyzed the clinical presentations of the 17 MSA patients carrying GD variants. The ages (in years) at symptom onset in these patients (58.1 ± 8.2) did not differ significantly (*P* = 0.93) from those in noncarriers (57.9 ± 8.9). The male to female ratio of these patients (8–9) did not differ significantly (*P* = 0.47) from those of noncarriers (540 to 412). The clinical phenotypes of these 17 MSA patients included 14 MSA-C and three MSA-P subjects (Table 3). The carrier frequency of MSA-C patients was 2.17% (14 in 646) and that of MSA-P patients

was 1.11% (3 in 270). None of the 53 patients with undefined subtypes carried GD variants. Given that 11 in 1509 control subjects (0.73%) carried such variants, GD variants were significantly associated with MSA-C (adjusted OR, 2.99 [95% CI 1.35–6.79], *P* = 7.3 × 10<sup>−3</sup>). In the MSA-C group, a Mantel–Haenszel procedure of each series yielded a pooled OR of 3.00 (95% CI 1.37–6.59) with a *P*-value of 6.3 × 10<sup>−3</sup> (Fig. S1). The heterogeneity of OR of each series from the Mantel–Haenszel analysis was not significant (Cochran *Q* = 2.82, *P* = 0.24; Breslow–Day = 3.48, *P* = 0.18; *I*<sup>2</sup> = 29%). Although the carrier frequency is also higher in MSA-P patients than in control subjects, the association of GD variants with MSA-P is inconclusive (adjusted OR, 1.54 [95% CI 0.34–5.04], *P* = 0.51).

Interestingly, we occasionally see siblings or other family members of the patients with MSA who are affected with PD. Among the five sib-pairs with sporadic MSA and PD, where genomic DNA samples are available (Families P2, P29, P30, P31, and P32 in Fig. 2), one sib-pair (Family P29) share the same heterozygous GD mutation, G202R. In another sib-pair (Family P2), one PD patient discordantly had a heterozygous GD variant (RecNci). *SNCA* single-nucleotide substitutions and multiplications were not present in the affected members of these pedigrees (data not shown).

Independent of the above analyses, we additionally analyzed affected members in six multiplex families with MSA reported previously.<sup>8</sup> Of the six multiplex MSA

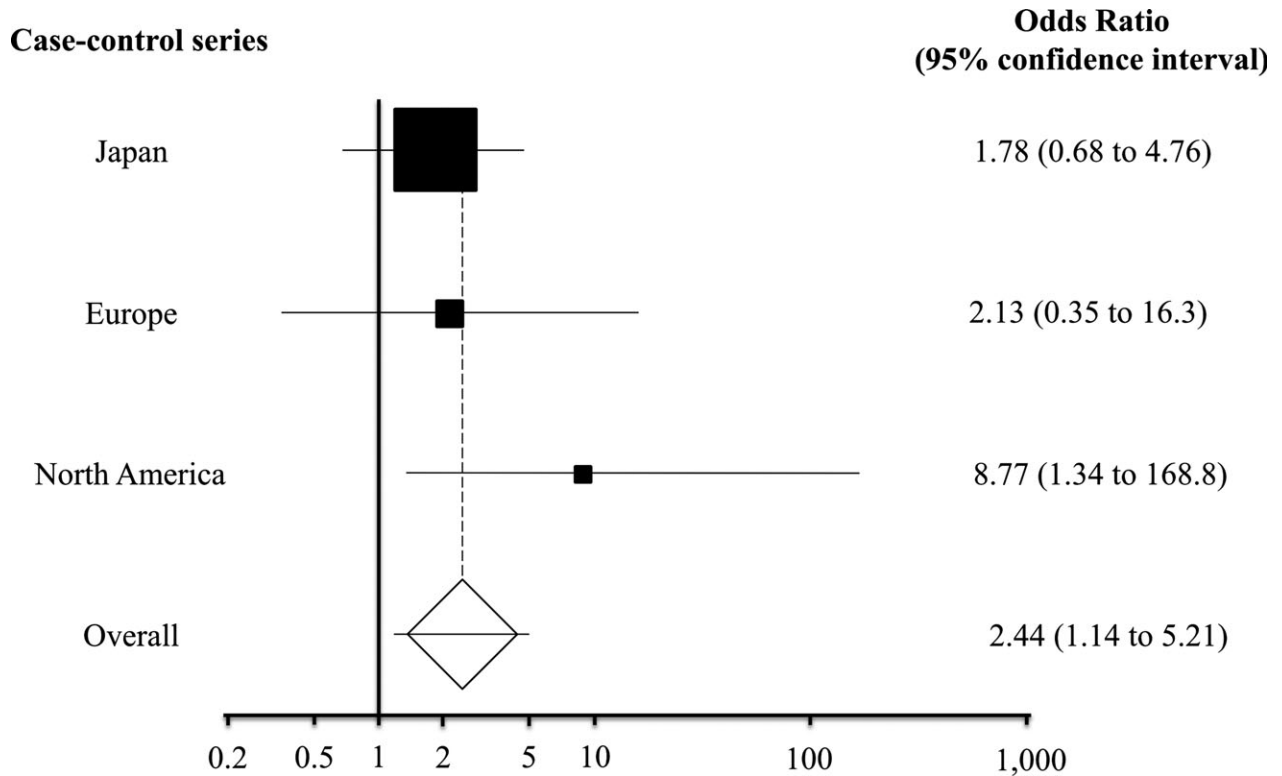
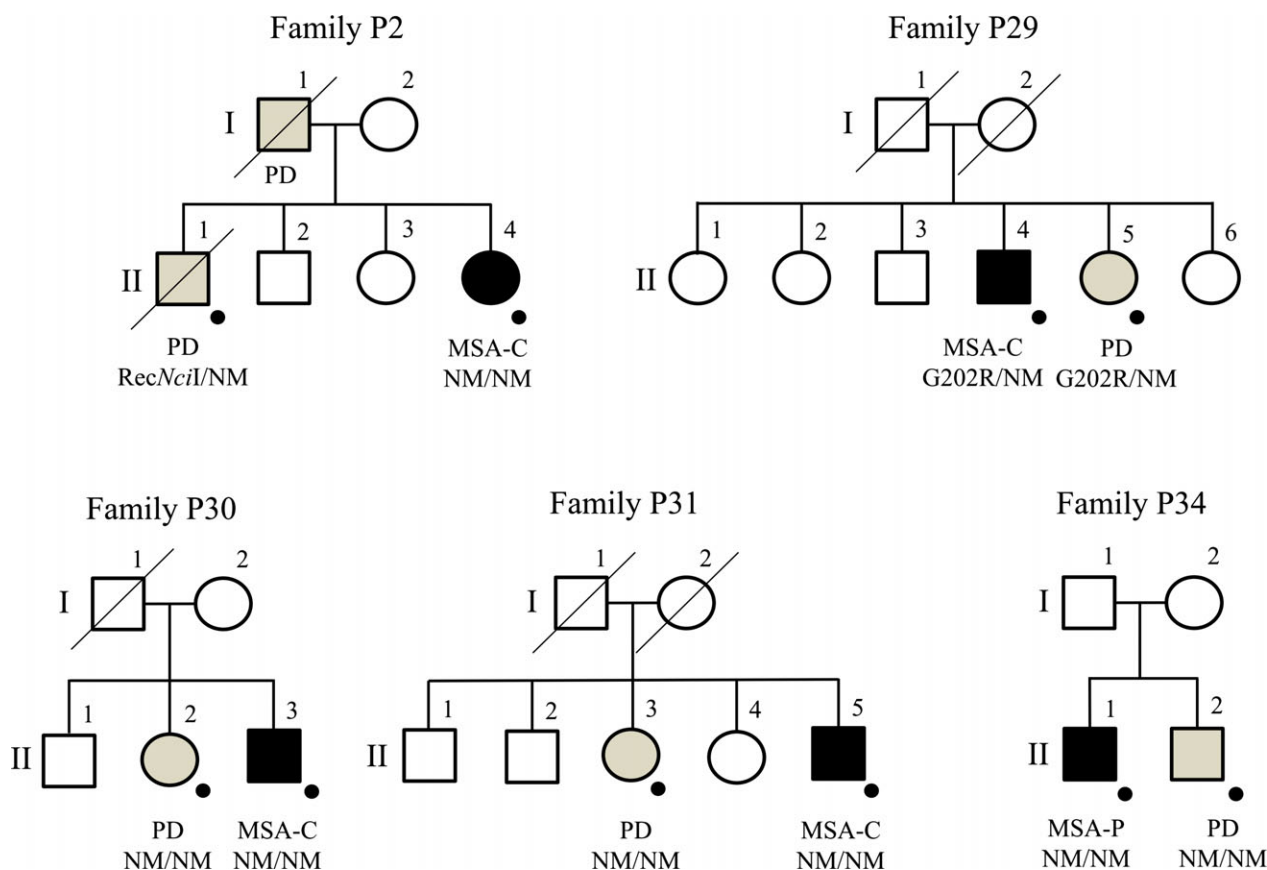

**Figure 1.** Odds ratios for GD-causing *GBA* variants among MSA patients, as compared with controls, at each case-control series and overall. Shown are the combined estimates (on a log<sub>10</sub> scale) of the odds ratios for carrying GD variants. The odds ratio estimate is marked with a solid black square. The lines represent the 95% confidence interval of odds ratio estimate. The size of the square represents the weight that the corresponding series exerts in the Mantel-Haenszel analysis. Confidence intervals of pooled odds ratios are displayed as a horizontal line through the diamond. The heterogeneity of odds ratio of each series from the Mantel-Haenszel analysis was not significant (Cochran  $Q = 1.80$ ,  $P = 0.41$ ; Breslow-Day = 1.99,  $P = 0.37$ ;  $I^2 = 0\%$ ), indicating that there is no effect modification by the series (population). *GBA*, Glucocerebrosidase; *MSA*, multiple system atrophy; *GD*, Gaucher disease.

**Table 3.** Gaucher-disease-causing *GBA* variants in combined series in each clinical subtype.

Genotypes	Cases			Controls
	MSA-C patients ( <i>n</i> = 646)	MSA-P patients ( <i>n</i> = 270)	Undefined subtypes patients ( <i>n</i> = 53)	Control subjects ( <i>n</i> = 1509)
R120W/NM	1	0	0	0
G202R/NM	1	0	0	0
F213I/NM	2	0	0	1
N370S/NM	2	1	0	0
N370S/N370S	1	1	0	2
G377S/NM	1	0	0	0
D409H/NM	0	0	0	1
L444P/NM	5	1	0	2
L444R/NM	1	0	0	0
RecNcil/NM	0	0	0	5
Total	14/646 (2.17%)	3/270 (1.11%)	0/53 (0.00%)	11/1509 (0.73%)
Adjusted odds ratio (95% confidence interval)	2.99 (1.35–6.79)	1.54 (0.34–5.04)	NA	NA
Fisher's exact test	$P = 7.3 \times 10^{-3}$	$P = 0.51$	NA	NA

*GBA*, Glucocerebrosidase; *MSA-C*, multiple system atrophy of the cerebellar type; *MSA-P*, multiple system atrophy parkinsonism subtype; *NM*, nonmutated allele; *NA*, not applicable.



**Figure 2.** Identification of Gaucher-disease-causing *GBA* variants in sib-pairs with coincidence of MSA and PD. Squares represent men; circles, women; black symbols, individuals with MSA; gray symbols, individuals with PD; open symbols, unaffected individuals; dots, genomic DNAs available. *GBA*, Glucocerebrosidase; MSA-C, multiple system atrophy of the cerebellar type; MSA-P, multiple system atrophy with predominant parkinsonism; PD, Parkinson disease; NM, nonmutated allele.

families, we found that three of the four patients with MSA in Family 8 had GD variants, whereas we did not observe GD variants in other families. In Family 8, three patients with MSA-P (III-2, III-4, and III-6) including one (III-6) with autopsy-proven MSA (definite MSA) had the same heterozygous GD variant (L444R) (Fig. 3), whereas the other patient with MSA-C (IV-1) did not carry the variant. In addition, one unaffected sibling (III-5) carried the variant, whereas the other unaffected sibling (III-1) did not carry the variant. Thus, although cosegregation of the GD variant with MSA was not complete in this family, the observation may also support some association of GD variants with MSA.

## Discussion

In this study, we demonstrated that GD variants are associated with MSA, raising a possibility that MSA, PD, and DLB partly share genetic risk factors. The carrier frequency of GD variants in MSA is 1.75% in the combined Japanese, European, and North American series. This is

in a striking contrast to a much higher carrier frequency of ~7% in PD, suggesting that impact of GD variants as a risk factor for MSA is weaker compared to that for PD.<sup>17</sup>

We focused solely on GD variants that have been reported to be pathogenic mutations for GD, and this makes it difficult to interpret the pathogenicity of other rare variants that have not been reported to cause GD. As a considerable number of rare variants with unknown significance were identified in this study, functional analysis of each mutant *GBA* would be required to determine whether they are functionally neutral variants or potentially pathogenic for GD.

Diagnosis of MSA was made according to the current consensus criteria in this study. Although there is an inherent risk for clinical misdiagnosis, which would limit the interpretations of our findings, it should also be noted that to evaluate associations of rare variants with diseases as encountered in this study, substantially large sample sizes are required to accomplish a sufficient detection power. Nonetheless, it is noteworthy that GD variants were significantly associated with MSA-C, given that the clinical



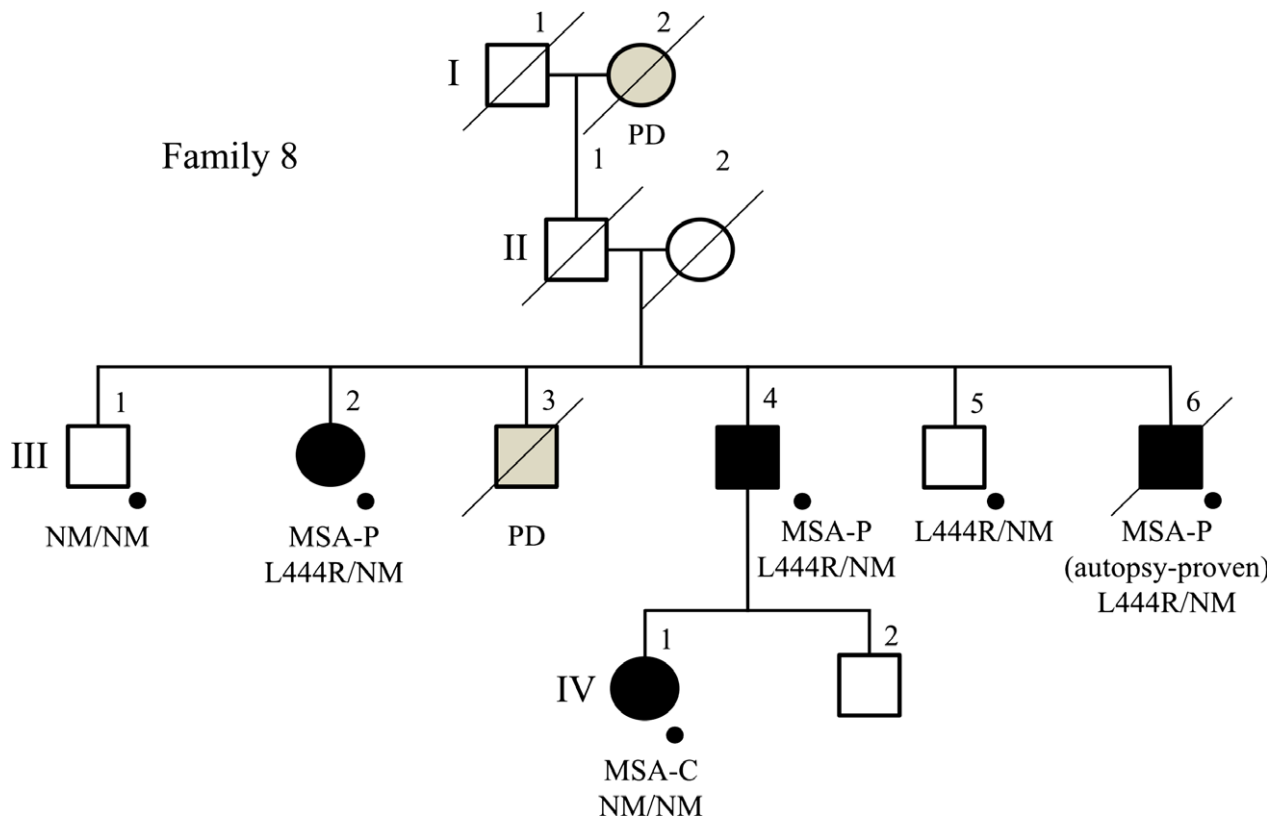

**Figure 3.** Identification of Gaucher-disease-causing *GBA* variants in a multiplex family with MSA. The diagnosis of definite MSA in III-6 in Family 8 was confirmed by autopsy findings. Squares represent men; circles, women; black symbols, individuals with MSA; gray symbols, individuals with PD; open symbols, unaffected individuals; dots, genomic DNAs available. *GBA*, Glucocerebrosidase; MSA-P, multiple system atrophy with predominant parkinsonism; PD, Parkinson disease; NM, nonmutated allele.

presentation of MSA-C is distinct from that of PD and inclusion of patients with PD in the MSA-C group is unlikely.<sup>1</sup> Although the carrier frequency is also higher in MSA-P patients than in control subjects, the association of GD variants with MSA-P is inconclusive. Given their limited sample size ( $n = 270$ ) in this study, analysis of a larger case series will be needed to answer the question of whether GD variants are also associated with MSA-P.

In the five sib-pairs with coincidence of MSA and PD and the six multiplex families with MSA, it is noteworthy that, despite the low frequency of carriers of the GD variants in the Japanese controls (0.89%), GD variants were identified, and shared by affected siblings in Family P29 (one sibling with MSA-C and one with PD) and Family 8 (three siblings with MSA-P). None of the affected individuals (either MSA or PD) carried deleterious variants in *COQ2* (data not shown). Although the number of families is limited and cosegregation is not complete in Family 8, these observations may support the increased risk of GD variants in developing MSA, leading to familial clustering.

In our previous study, we showed that the carrier frequency of V393A in *COQ2* was significantly higher in

Japanese MSA patients (9.1%) than in Japanese controls (3.3–4.4%) with odds ratios of 2.1–3.0.<sup>8</sup> It is remarkable that among the nine MSA patients carrying GD variants in the Japanese series, two MSA-C patients had GD variants (one F213I and one L444P) and V393A variants in *COQ2* simultaneously, both in heterozygous states (data not shown). Their ages at onset were both 54 years, which is slightly younger than the average age at onset of 58.7 years in the Japanese MSA patients. As the number of patients carrying both alleles is limited, the biological relevance of the combination of *GBA* and *COQ2* variants in the pathogenesis of MSA remains to be determined.

Previous studies have shown no significant associations of GD variants with MSA,<sup>31–34</sup> perhaps because of smaller sample sizes, and perhaps because these studies analyzed only specific variants (L444P and/or N370S). The concordant trend of increased risk of GD variants for developing MSA in each of the three series utilized in this study (Japanese, European, and North American) strengthens our conclusion and makes a bias of stratification unlikely.

Since discovery of the genetic association between *GBA* and PD, the biological relationships between mutant *GBA*

and  $\alpha$ -synuclein have been investigated intensively. Use of induced pluripotent stem cells from PD patients with GD variants revealed that GBA activity was reduced, glucosylceramide and  $\alpha$ -synuclein levels were increased, and both autophagy and ubiquitin-proteasome pathways were defective in derived dopaminergic neurons.<sup>35</sup> Moreover, a postmortem human brain study showed that, even in sporadic PD patients without GD variants, GBA activity was selectively reduced in the early stages of PD within regions containing increased  $\alpha$ -synuclein levels and limited LB formation.<sup>36</sup> While future replication studies on larger case-control series would be needed to verify the association of GBA mutations with MSA, studies on the biochemical effects associated with mutant GBA may contribute to better understanding the mechanisms underlying development of MSA as well as those underlying PD, and aid in developing novel therapeutic measures for this intractable disease.

## Acknowledgments

This study was supported in part by KAKENHI (Grant-in-Aid for Scientific Research on Innovative Areas [22129001 and 22129002]) to S. T.; the Global COE Program from the Ministry of Education, Culture, Sports, Science and Technology of Japan, a Grant-in-Aid (H23-Jitsuyoka [Nanbyo]-Ippan-004, and “the Research Committee for Ataxic Diseases” of the Research on Measures for Intractable Diseases) from the Ministry of Health, Welfare and Labour, Japan to S. T.; the French Agency for Research (ANR-09-MNPS-032-01/R09148DS) and the Programme Hospitalier de Recherche Clinique (AOM03059/R05129DD) to A. D. and A. B.; the Deutsche Forschungsgemeinschaft (Wu 184-6) the Deutsche Parkinson Vereinigung to U. W.; National Institutes of Health grant (NS-53488) to J. Q. T.; and National Institutes of Health grant (P01NS044233) to P. A. L. We thank Mio Takeyama, Keiko Hirayama, and Zhenghong Wu for their support in the laboratory experiments and Cecilia Marelli for her clinical input to this study. We also thank the DNA and Cell Bank of CRicm for technical assistance.

## Conflict of Interest

None declared.

## References

- Gilman S, Wenning GK, Low PA, et al. Second consensus statement on the diagnosis of multiple system atrophy. *Neurology* 2008;71:670–676.
- Papp MI, Kahn JE, Lantos PL. Glial cytoplasmic inclusions in the CNS of patients with multiple system atrophy (striatonigral degeneration, olivopontocerebellar atrophy and Shy-Drager syndrome). *J Neurol Sci* 1989;94:79–100.
- Nakazato Y, Yamazaki H, Hirato J, et al. Oligodendroglial microtubular tangles in olivopontocerebellar atrophy. *J Neuropathol Exp Neurol* 1990;49:521–530.
- Tu PH, Galvin JE, Baba M, et al. Glial cytoplasmic inclusions in white matter oligodendrocytes of multiple system atrophy brains contain insoluble alpha-synuclein. *Ann Neurol* 1998;44:415–422.
- Wakabayashi K, Yoshimoto M, Tsuji S, Takahashi H. Alpha-synuclein immunoreactivity in glial cytoplasmic inclusions in multiple system atrophy. *Neurosci Lett* 1998;249:180–182.
- Al-Chalabi A, Durr A, Wood NW, et al. Genetic variants of the alpha-synuclein gene SNCA are associated with multiple system atrophy. *PLoS One* 2009;4:e7114.
- Scholz SW, Houlden H, Schulte C, et al. SNCA variants are associated with increased risk for multiple system atrophy. *Ann Neurol* 2009;65:610–614.
- The Multiple-System Atrophy Research Collaboration. Mutations in COQ2 in familial and sporadic multiple-system atrophy. *N Engl J Med* 2013;369:233–244.
- Spillantini MG, Schmidt ML, Lee VM, et al. Alpha-synuclein in Lewy bodies. *Nature* 1997;388:839–840.
- Goedert M, Spillantini MG. Lewy body diseases and multiple system atrophy as alpha-synucleinopathies. *Mol Psychiatry* 1998;3:462–465.
- Kiely AP, Asi YT, Kara E, et al.  $\alpha$ -Synucleinopathy associated with G51D SNCA mutation: a link between Parkinson's disease and multiple system atrophy? *Acta Neuropathol* 2013;125:753–769.
- Pasanen P, Myllykangas L, Siitonen M, et al. A novel  $\alpha$ -synuclein mutation A53E associated with atypical multiple system atrophy and Parkinson's disease-type pathology. *Neurobiol Aging* 2014;35:2180.e1–2180.e5.
- Vidal JS, Vidailhet M, Derkinderen P, et al. Familial aggregation in atypical Parkinson's disease: a case control study in multiple system atrophy and progressive supranuclear palsy. *J Neurol* 2010;257:1388–1393.
- Nee LE, Gomez MR, Dambrosia J, et al. Environmental-occupational risk factors and familial associations in multiple system atrophy: a preliminary investigation. *Clin Auton Res* 1991;1:9–13.
- Fujioka S, Ogaki K, Tacik PM, et al. Update on novel familial forms of Parkinson's disease and multiple system atrophy. *Parkinsonism Relat Disord* 2014;20(Suppl 1):S29–S34.
- Mitsui J, Mizuta I, Toyoda A, et al. Mutations for Gaucher disease confer high susceptibility to Parkinson disease. *Arch Neurol* 2009;66:571–576.
- Sidransky E, Nalls MA, Aasly JO, et al. Multicenter analysis of glucocerebrosidase mutations in Parkinson's disease. *N Engl J Med* 2009;361:1651–1661.

18. Nalls MA, Duran R, Lopez G, et al. A multicenter study of glucocerebrosidase mutations in dementia with Lewy bodies. *JAMA Neurol* 2013;70:727–735.
19. Goker-Alpan O, Schiffmann R, LaMarca ME, et al. Parkinsonism among Gaucher disease carriers. *J Med Genet* 2004;41:937–940.
20. Koprivica V, Stone DL, Park JK, et al. Analysis and classification of 304 mutant alleles in patients with type 1 and type 3 Gaucher disease. *Am J Hum Genet* 2000;66:1777–1786.
21. Tsuji S, Choudary PV, Martin BM, et al. Nucleotide sequence of cDNA containing the complete coding sequence for human lysosomal glucocerebrosidase. *J Biol Chem* 1986;261:50–53.
22. Stone DL, Carey WF, Christodoulou J, et al. Type 2 Gaucher disease: the collodion baby phenotype revisited. *Arch Dis Child Fetal Neonatal Ed* 2000;82:F163–F166.
23. Kim MJ, Suh JT, Lee HJ, et al. Simultaneous detection of Gaucher's disease and renal involvement of non-Hodgkin's lymphoma: the first Asian case report and a review of literature. *Ann Clin Lab Sci* 2012;42:293–301.
24. He GS, Grace ME, Grabowski GA. Gaucher disease: four rare alleles encoding F213I, P289L, T323I, and R463C in type 1 variants. *Hum Mutat* 1992;1:423–427.
25. Cormand B, Grinberg D, Gort L, et al. Two new mild homozygous mutations in Gaucher disease patients: clinical signs and biochemical analyses. *Am J Med Genet* 1997;70:437–443.
26. Amaral O, Marcão A, Sá Miranda M, et al. Gaucher disease: expression and characterization of mild and severe acid beta-glucosidase mutations in Portuguese type 1 patients. *Eur J Hum Genet* 2000;8:95–102.
27. Michelakakis H, Dimitriou E, Van Weely S, et al. Characterization of glucocerebrosidase in Greek Gaucher disease patients: mutation analysis and biochemical studies. *J Inherit Metab Dis* 1995;18:609–615.
28. Walley AJ, Barth ML, Ellis I, et al. Gaucher's disease in the United Kingdom: screening non-Jewish patients for the two common mutations. *J Med Genet* 1993;30:280–283.
29. Uchiyama A, Tomatsu S, Kondo N, et al. New Gaucher disease mutations in exon 10: a novel L444R mutation produces a new NciI site the same as L444P. *Hum Mol Genet* 1994;3:1183–1184.
30. Horowitz M, Pasmanik-Chor M, Ron I, Kolodny EH. The enigma of the E326K mutation in acid  $\beta$ -glucocerebrosidase. *Mol Genet Metab* 2011;104:35–38.
31. Segarane B, Li A, Paudel R, et al. Glucocerebrosidase mutations in 108 neuropathologically confirmed cases of multiple system atrophy. *Neurology* 2009;72:1185–1186.
32. Jamrozik Z, Lugowska A, Slawek J, Kwiecinski H. Glucocerebrosidase mutations p.L444P and p.N370S are not associated with multisystem atrophy, progressive supranuclear palsy and corticobasal degeneration in Polish patients. *J Neurol* 2010;257:459–460.
33. Sun QY, Guo JF, Han WW, et al. Genetic association study of glucocerebrosidase gene L444P mutation in essential tremor and multiple system atrophy in mainland China. *J Clin Neurosci* 2013;20:217–219.
34. Srulijes K, Hauser AK, Guella I, et al. No association of GBA mutations and multiple system atrophy. *Eur J Neurol* 2013;20:e61–e62.
35. Schöndorf DC, Aureli M, McAllister FE, et al. iPSC-derived neurons from GBA1-associated Parkinson's disease patients show autophagic defects and impaired calcium homeostasis. *Nat Commun* 2014;5:4028.
36. Murphy KE, Gysbers AM, Abbott SK, et al. Reduced glucocerebrosidase is associated with increased  $\alpha$ -synuclein in sporadic Parkinson's disease. *Brain* 2014;137:834–848.

## Supporting Information

Additional Supporting Information may be found in the online version of this article:

**Figure S1.** Odds ratios for Gaucher-disease-causing *GBA* variants among MSA-C patients, as compared with controls, at each case-control series and overall. Shown are the combined estimates (on a  $\log_{10}$  scale) of the odds ratios for carrying GD variants among MSA-C patients. The odds ratio estimate is marked with a solid black square. The lines represent the 95% confidence interval of odds ratio estimate. The size of the square represents the weight that the corresponding series exerts in the Mantel-Haenszel analysis. Confidence intervals of pooled odds ratios are displayed as a horizontal line through the diamond. The heterogeneity of odds ratio of each series from the Mantel-Haenszel analysis was not significant (Cochran  $Q = 2.82$ ,  $P = 0.24$ ; Breslow-Day = 3.48,  $P = 0.18$ ;  $I^2 = 29\%$ ), indicating that there is no effect modification by the series (population).

**Table S1.** Nonsynonymous variants in *GBA* that have not been reported to be causative for Gaucher disease.