



HAL
open science

Low Power Load Interface For Vibrational Energy MEMS harvesters

Mohammed Bedier, Dimitri Galayko

► **To cite this version:**

Mohammed Bedier, Dimitri Galayko. Low Power Load Interface For Vibrational Energy MEMS harvesters. Journées Nationales sur la Récupération et le Stockage d'Énergie (JNRSE'2016), Le laboratoire IMS May 2016, Bordeaux, France. hal-01371851

HAL Id: hal-01371851

<https://hal.sorbonne-universite.fr/hal-01371851>

Submitted on 26 Sep 2016

HAL is a multi-disciplinary open access archive for the deposit and dissemination of scientific research documents, whether they are published or not. The documents may come from teaching and research institutions in France or abroad, or from public or private research centers.

L'archive ouverte pluridisciplinaire **HAL**, est destinée au dépôt et à la diffusion de documents scientifiques de niveau recherche, publiés ou non, émanant des établissements d'enseignement et de recherche français ou étrangers, des laboratoires publics ou privés.

Low Power Load Interface For Vibrational Energy MEMS harvesters

M. Bedier

Universite Pairs-Sorbonne, UPMC Paris 6, LIP6
Paris, France
Mohammed.bedier@lip6.fr

Dimitri Galayko

Universite Paris-Sorbonne, UPMC Paris 6, LIP6
Paris, France
Dimitri.galayko@lip6.fr

Abstract— Electrostatic vibrational energy harvesting is an appealing source power for self powered wireless sensors. With many pervious successful implementation of energy harvesters, a power efficient load interface is needed. This article describes multiple energy-shot load interface for vibrational energy MEMS harvester with a low power decision mechanism.

Keywords— Energy harvesting; MEMS; Electrostatic converters; Ambient vibration

I. INTRODUCTION

The harvesting of ambient energy has gained increased interest with the emerge of IoT revolution specially with the need of self power sensors and energy aware electronics design. Electrostatic energy harvesting is among the promising techniques to extract the ambient energy and use it instead of traditional battery cells. The energy is harnessed by taking advantage of the vibrational force and allowing it to act against an electrostatic force by the mean of a conditioning circuit (CC). The Miniaturized Vibrational electrostatic energy harvesters (e-VEH) are implemented using a variable capacitor MEMS free to move with the mechanical vibration, thus disturbing the charges in the CC which results in an accumulated energy on a reservoir capacitor (C_{res}).

A completed energy harvesting system is composed of a CC, load interface (LI) and output voltage regulator. The CC extracts the energy from ambient vibration, while the output voltage regulator guaranties a constant voltage supplied to the load. Due to the nature of e-VEH, the harvested energy on C_{res} can exhibit a high voltage as well as large - yet slow - variations. Thus, a load interface (LI) is needed as an intermediate stage between the CC and the voltage regulator. The e-VEH and CC have been studied extensively, such as in [1]-[4]. However, a LI that efficiently transfers the harvested energy to a temporary low voltage load buffer C_{buffer} , were merrily addressed. This work presents a low power LI with a multiple energy-shot scheme.

II. LOAD INTERFACE ENERGY MANAGEMENT

A. Energy harvester system discription

The energy is harvested by a conditioning circuit (CC) as shown in Figure 1. The CC shown is one of various circuits implementing rectangular QV cycles and is chosen for demonstration purpose. It is a charge pump CC based on [4] with a flyback architecture. The LI maintains the CC at the maximum energy extraction interval, and stores the harvested energy to be later regulated for the load.

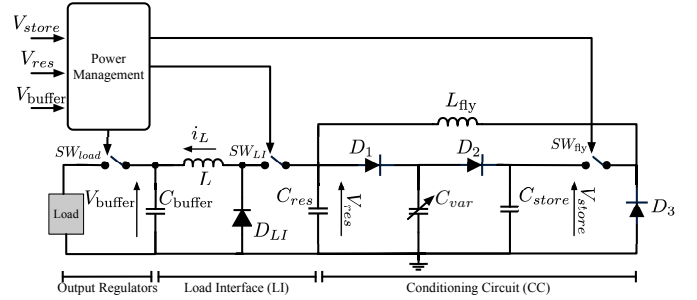

Fig. 1. E-VEH energy harvesting system with LI and voltage regulator.

The LI is a switched inductor capacitive architecture. It is composed of an inductor (L), freewheeling diode (D_{LI}), buffer capacitor (C_{buffer}) and a high side high voltage switch (SW_{LI}). The C_{buffer} is a temporary low voltage storage capacitor. The switches SW_{LI} and SW_{load} are used to activated/deactivate the LI and load regulator. The switching decision are made by a power management system.

B. Multiple shot energy transfer

For maximum harvested energy rate, the reservoir voltage V_{res} is contained with in an optimum interval [5][6]. During the harvesting operation, if V_{res} exists its optimum interval, it is forced back by activating the LI thus transferring a part of its energy into C_{buffer} . Nevertheless, V_{res} is guarantied not to fall below the optimum interval, as the LI is then deactivated, allowing V_{res} to recover back using the continuous generation of energy by the CC. The optimum interval is defined as $V_{resL} < V_{res} < V_{resH}$, where V_{resH} and V_{resL} are the high and low optimum energy harvesting interval thresholds. Assuming a lossless energy transfer, the energy to be removed from C_{res} to drop its voltage from V_{resH} to V_{resL} is,

$$\Delta W = \frac{1}{2} C_{res} (V_{resH}^2 - V_{resL}^2) \quad (1)$$

This energy is transferred through the inductor (L) with a current (i_L) defined as,

$$i_L(t) = \sqrt{\frac{C_{eq}}{L}} (V_{buffer_0} - V_{res_0}) \sin(\omega t), \quad 0 < t < t_{on}(2)$$

Where, t_{on} is the ON time of the switch SW_{LI} required to transfer ΔW , $\omega = \sqrt{1/LC_{eq}}$ and C_{eq} is the equivalent capacitance of C_{buffer} and C_{res} .

The technology of which the switch is implemented sets an upper limit on the inductor current (I_{Lmax}). Nevertheless, high

inductor current may result in large I^2R losses as well as device stress. To transfer ΔW without exceeding $I_{L,max}$, the energy is transferred in a multiple of shots instead of a single shot as shown in Figure 2. Each shot is of a fixed duration (t_{shot}) with two phases of operation. In the first phase a part of energy (δW_n) is removed from C_{res} during t_{I1} , while the second phase allows W_n to accumulate on C_{buffer} for t_{II} . This process is repeated n times until ΔW is extracted from C_{res} . The next section describes transistor level implementation of the load interface.

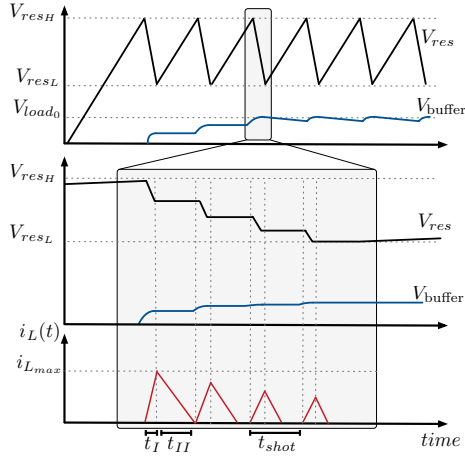

Fig. 2. Evolution of V_{res} , V_{buffer} and i_L in multiple shot energy transfer.

III. LOAD INTERFACE CONTROLLER

The load interface controller is implemented using a $0.35\mu\text{m}$ technology by AMSH35. First, V_{res} is sampled by a voltage divider using one of two sampling frequencies corresponding to two modes (idle and switching). The idle mode is activated when C_{res} accumulates energy from the harvester, while the switching mode is when C_{res} transfers ΔW to C_{buffer} . Second, the sampled scaled version of V_{res} is introduced to an RS-trigger based hysteresis comparator with its hysteresis gap fitted to the optimum interval of V_{res} . The comparator output controls SW_{LI} state, the clock selection and multiple energy shot pulse generations. Figure 3 shows the schematic of the LI controller.

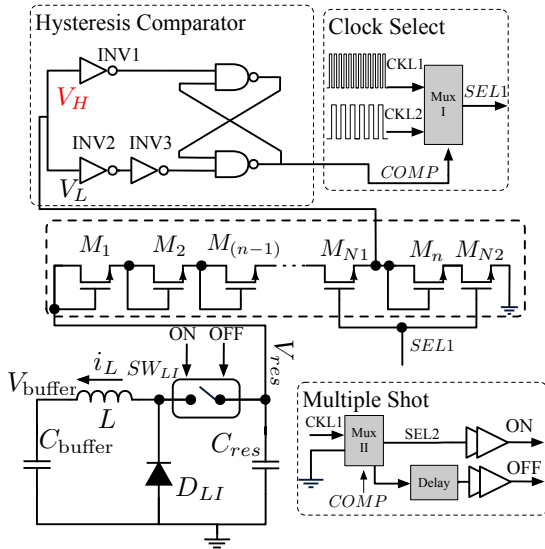

Fig. 3. Schematic of Load Interface Controller.

IV. SIMULATION AND RESULTS

The load interface and its controller is simulated with the design parameters of $L = 15\text{mH}$, $C_{res} = 1\mu\text{F}$, $C_{buffer} = 20\mu\text{F}$, and optimum interval of $7\text{V} < V_{res} < 6\text{V}$. The maximum allowed inductor current $I_{L,max} = 15\text{mA}$ defines $t_{I1} = 25\mu\text{s}$ and $t_{II} = 375\mu\text{s}$. The simulation shown in Figure 4 shows the energy transfer process. The power consumption is mainly by the hysteresis comparator, which has maximum instantaneous power consumption of 13.67nW . The energy consumed by the comparator in 10ms duration is 126.52pJ .

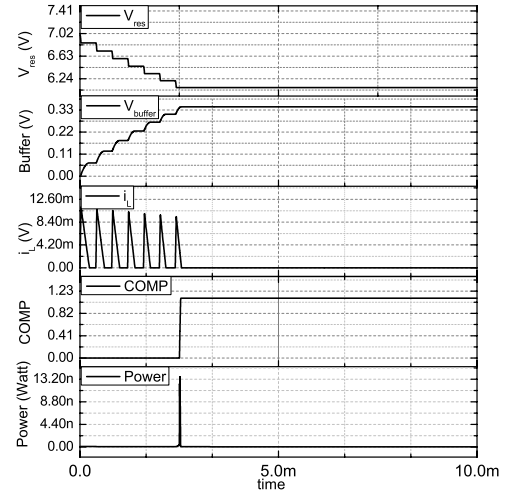

Fig. 4. Load interface controller simulation showing instantaneous power consumption of the hysteresis comparator.

V. CONCLUSION

A load interface is presented for vibrational energy harvesters with a multiple energy shot interface. The comparator energy consumption of the load interface is substantially decreased by using an RS-trigger based comparator. Further optimization of other supporting blocks, such as the multiplexers and clocks, can help decrease the power consumption. The ongoing work is toward fully integrating the harvester with the load interface and achieve autonomous operation.

REFERENCES

- [1] P. Basset, D. Galayko, A. M. Paracha, F. Marty, A. Dudka, and T. Bourouina, "A batch-fabricated and electret-free silicon electrostatic vibration energy harvester," *Journal of Micromechanics and Microengineering*, vol. 19, p. 115025, Oct. 2009.
- [2] E. O. Torres and G. A. Rincon-Mora, *Energy budget and high-gain strategies for voltage-constrained electrostatic harvesters*. IEEE, 2009.
- [3] A. Kempitaya and D. A. Borca-Tasciuc, "Analysis and optimization of asynchronously controlled electrostatic energy harvesters," *IEEE Transactions on Industrial Electronics*, 2012.
- [4] B. C. Yen and J. H. Lang, "A variable-capacitance vibration-to-electric energy harvester," *IEEE Transactions on Circuits and Systems I: Regular Papers*, vol. 53, pp. 288–295, 2006.
- [5] P. Basset, E. Blokhina, and D. Galayko, *Electrostatic Kinetic Energy Harvesting: Nanotechnologies for Energy Recovery*. Set. Wiely, 2016.
- [6] A. Karami, P. Basset, and D. Galayko, "Electrostatic vibration energy harvester using an electret-charged MEMS transducer with an unstable auto-synchronous conditioning circuit," *Journal of Physics: Conference Series*, vol. 660, p. 012025, 2015.