

60 GHz stepped impedance filter using Planar Goubau line technology

Emad Elrifai, Marjorie Grzeskowiak, Gaelle Lissorgues, Frédérique Deshours, Gerard Garrar, Elodie Richalot, Odile Picon

► **To cite this version:**

Emad Elrifai, Marjorie Grzeskowiak, Gaelle Lissorgues, Frédérique Deshours, Gerard Garrar, et al.. 60 GHz stepped impedance filter using Planar Goubau line technology. 2016 IEEE International Conference on Electronics, Circuits and Systems (ICECS), Dec 2016, Monte Carlo, Monaco. pp.153-156, 10.1109/ICECS.2016.7841155 . hal-01555768

HAL Id: hal-01555768

<https://hal.sorbonne-universite.fr/hal-01555768>

Submitted on 11 Jul 2019

HAL is a multi-disciplinary open access archive for the deposit and dissemination of scientific research documents, whether they are published or not. The documents may come from teaching and research institutions in France or abroad, or from public or private research centers.

L'archive ouverte pluridisciplinaire **HAL**, est destinée au dépôt et à la diffusion de documents scientifiques de niveau recherche, publiés ou non, émanant des établissements d'enseignement et de recherche français ou étrangers, des laboratoires publics ou privés.



Open Archive Toulouse Archive Ouverte (OATAO)

OATAO is an open access repository that collects the work of some Toulouse researchers and makes it freely available over the web where possible.

This is an author's version published in: <https://oatao.univ-toulouse.fr/24078>

Official URL : <https://doi.org/10.1109/ICECS.2016.7841155>

To cite this version :

Elrifai, Emad and Grzeskowiak, Marjorie and Lissorgues, Gaëlle and Deshours, Frédérique and Carrer, Gérard and Richalot, Elodie and Picon, Odile 60 GHz stepped impedance filter using Planar Goubau line technology. (2016) In: 2016 IEEE International Conference on Electronics, Circuits and Systems (ICECS), 11 December 2016 - 14 December 2016 (Monte Carlo, Monaco).

Any correspondence concerning this service should be sent to the repository administrator:

tech-oatao@listes-diff.inp-toulouse.fr

60 GHz Stepped Impedance Filter using Planar Goubau Line Technology

E. ELRIFAI¹, M. GRZESKOWIAK¹, G. LISSORGUES², F. DESHOURS³, G. CARRER¹, E. RICHALOT¹, O. PICON¹

¹Université Paris-Est, ESYCOM (EA 2552), UPEMLV, ESIEE-Paris, CNAM, F-77454 Marne-la-Vallée, France.

²Université Paris-Est, ESYCOM (EA 2552), UPEMLV, ESIEE-Paris, CNAM, F-93162 Noisy-le-Grand, France.

³Sorbonne Universités, UPMC Univ Paris 06, UR2, L2E, F-75005, Paris, France.

Abstract— This paper presents a fifth order stepped impedance low-pass filter using low loss Planar Goubau Line (PGL) technology on high resistivity Silicon substrate at millimeter-wave frequencies. The filter is simulated and optimized using 3D full-wave electromagnetic field simulations performed on HFSS (High Frequency Simulator Structure). On-wafer measurements in the 50-65 GHz band are in good agreement with simulation results. At 60 GHz, the measured insertion loss is 3.6dB which includes the two coplanar waveguide-to-GPL transitions.

Keywords— Stepped impedance filter; low-pass filter; 60 GHz; Planar Goubau Line (PGL)

I. INTRODUCTION

Performance, miniaturization, fabrication easiness and low cost are the usual aims behind the evolution of different electronic components, whose achievement depends on the characteristics of the used technology.

Thanks to its low cost, its low dispersion and its simple fabrication process, the Planar Goubau line (PGL) which is the planar version of Goubau line (single conductor line surrounded by dielectric) has been studied and used for different components: antennas [1], filters and resonators [2] at millimeter frequency band up to THz [3]. The planar structure of Goubau line has been presented on high resistivity Silicon substrate in [4], and showed very low insertion losses (< 0.07 dB/mm) in the unlicensed frequency band of 60 GHz. The filters play an important role in microwave and millimeter communication systems and most of them are designed using a micro-strip technology. A band-pass filter fabricated on alumina ceramic shows a measured insertion loss less than 4dB over 3 GHz band at 60GHz [5]. For suspended line technology, a low-pass stepped impedance filter is simulated in [6] on CST (Computer Simulation Technology) and has presented insertion loss of 2.5 dB at 60GHz.

This paper presents a stepped impedance low-pass filter at 60 GHz designed in a PGL technology. It is organized as following: in Section II, we describe the PGL structure and the filter design. 3D electromagnetic simulation results performed using numerical full-wave calculations with HFSS (High Frequency Simulator Structure) are presented and compared with on-wafer measurements in Sections III and IV. Finally, the main conclusions are summarized in Section V.

II. FILTER DESIGN

A. Planar Goubau Line (PGL)

A Planar Goubau Line (PGL) structure consists of a single metallic strip on a dielectric substrate without any ground plane. In [4], the PGL is designed on a high resistivity Silicon substrate of $500 \mu\text{m}$ thickness with a gold metallization of $1 \mu\text{m}$. To miniaturize the structure, the thickness of high resistivity Silicon is reduced to $350 \mu\text{m}$ (Fig. 1a).

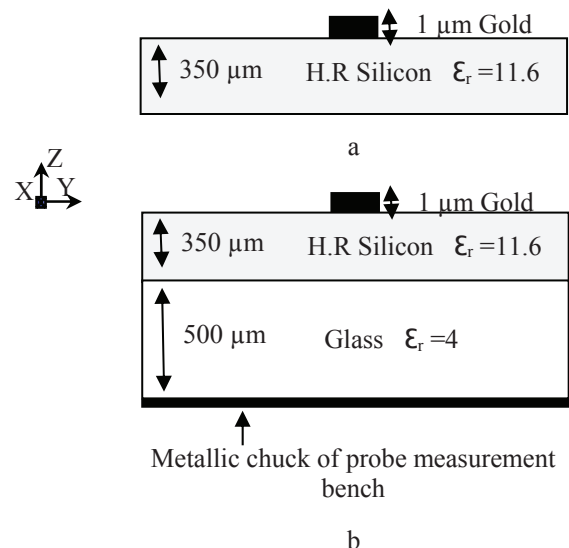

Fig. 1. Planar Goubau Line Structure (PGL), a. on Silicon substrate, b. on Silicon+Glass substrate+metallic chuck

As the filter is measured on-wafer and positioned on the metallic chuck of the probe station, we have added a $500 \mu\text{m}$ glass substrate under the Silicon substrate to minimize the related field disturbance (Fig. 1.b). As shown in Fig. 2.b, the glass substrate addition allows reducing the disturbance of the metallization chuck on the PGL propagation. Its effect on the PGL propagation mode can be neglected: we can consider that there is no noticeable effect of the chuck on filter measurements after adding the glass substrate.

We have also designed a coplanar-PGL tapered transition to perform on-wafer measurements with coplanar probes and to match the 50Ω PGL access of the filter to the 50Ω coplanar probe access.

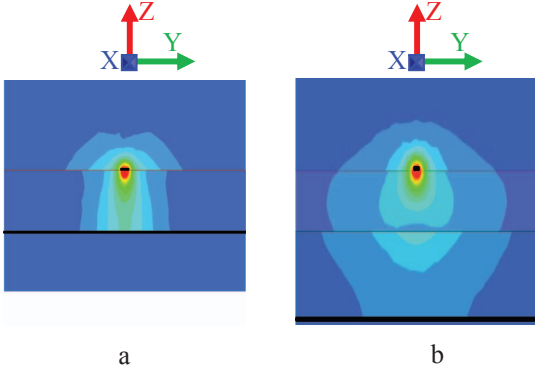

Fig. 2. Magnitude of electric field in transverse plane (y_0z) with metallic chuck, a. PGL on Silicon, b. PGL on Silicon+ Glass

B. Procedure of Filter Design

The millimeter low-pass filter has the following aimed characteristics: cutoff frequency f_c of 60 GHz, pass-band ripple of 0.5dB, insertion loss around -15dB at 67GHz. The filter must have a 50Ω characteristic impedance at both its input and output ports. According to these specifications, we have chosen a fifth order ($n=5$) filter with a Chebyshev approximation. The normalized element values obtained from tables are [7]: $g_0 = g_6 = 1$, $g_1 = g_5 = 1.7058$, $g_2 = g_4 = 1.2296$, $g_3 = 2.5408$

For the π -section circuit topology, LC component values can be calculated as follows [7]:

$$L_i = (g_i Z_0) / (2\pi f_c) \quad \text{if } i \text{ is even} \quad (1)$$

$$C_i = g_i / (Z_0 2\pi f_c) \quad \text{if } i \text{ is odd} \quad (2)$$

Using design equations of stepped impedance low-pass filter [7], the lengths of transmission line sections are found and reported in Table I.

g_i	L_i (nH)	C_i (fF)	Z_{0i} (Ω)	L_i (μm)	W_i (μm)
1			50	500	350
1.3394		92	30	46	600
1.337	0.16		98	53	50
2.166		138	20	61	800
1.337	0.16		98	53	50
1.3394		92	30	46	600
1			50	500	350

It is important to note that the transmission line tool LineCalc in ADS (Advanced Design System) considers a micro-strip mode (with ground plane), while the filter structure is fabricated using a planar Goubau line technology (without ground plane): the lumped elements are therefore modified in distributed elements (Table I). An electromagnetic

parametric simulation on planar Goubau lines has been done using HFSS to obtain the line widths corresponding to the characteristic impedances that has been chosen: High-impedance sections (98Ω) of the GPL synthesize the inductors and low-impedance sections (20 and 30Ω) replace the capacitors of the low-pass filter.

The stepped impedance low-pass filter layout and the corresponding planar transmission lines for each LC element are depicted in Fig.3. Z_{0C} and Z_{0L} are respectively the characteristic impedances of the low and high impedance lines. We assume that the source and load impedances are 50Ω .

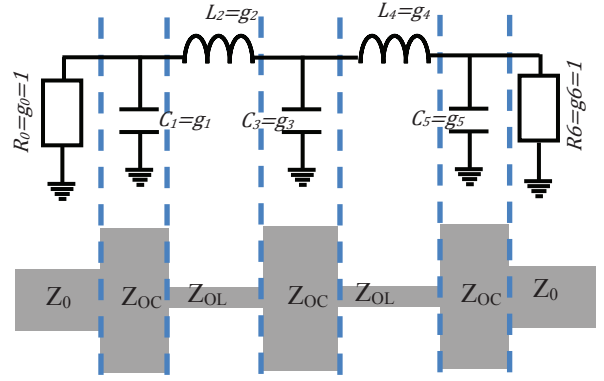

Fig. 3. Electrical equivalent circuit of the stepped impedance low-pass filter and its layout in PGL technology

Fig. 4 shows the ideal frequency response of the LC filter simulated using ADS up to 70 GHz. The pass-band ripple of 0.5dB is clearly visible. The lumped-element low-pass filter presents also an attenuation of 0.5dB at f_c and the return loss is better than 10 dB.

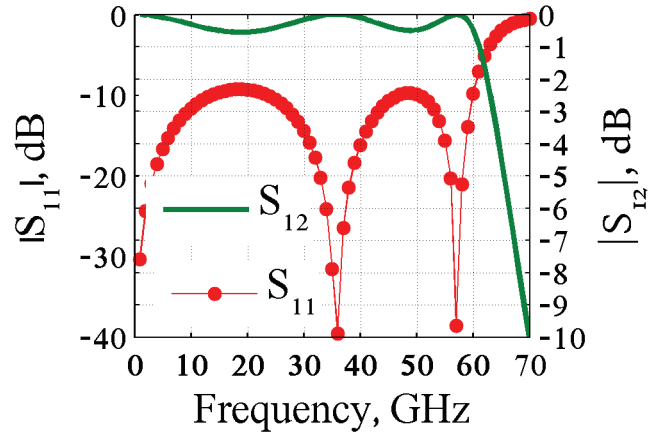

Fig. 4. Simulated S-parameters with ADS

III. 3D ELECTROMAGNETIC SIMULATIONS

First, the structure of the stepped impedance low-pass filter without coplanar-PGL transition is simulated and optimized using HFSS between 40 and 70 GHz (Fig.5.a). The value of widths obtained for the lumped elements are designed under

HFSS for the planar Goubau line and then, slightly modified to take into account the coupling between the different line sections. The transmission parameter is around 2.9 dB at 64GHz, in electromagnetic simulation: we consider all the losses: metallic, dielectric and radiating losses. In electrical simulation, the transmission is around 3.5 dB at 64GHz, the electrical model is designed with capacitors and inductors without resistors.

The impedance matching seems better with HFSS, as the reflection coefficient is determined for an access characteristic impedance equal to the Goubau line one, that varies between 48 and 52 Ω over the frequency band 55-67 GHz, while on ADS simulator the excitation ports have 50 Ω characteristic impedances.

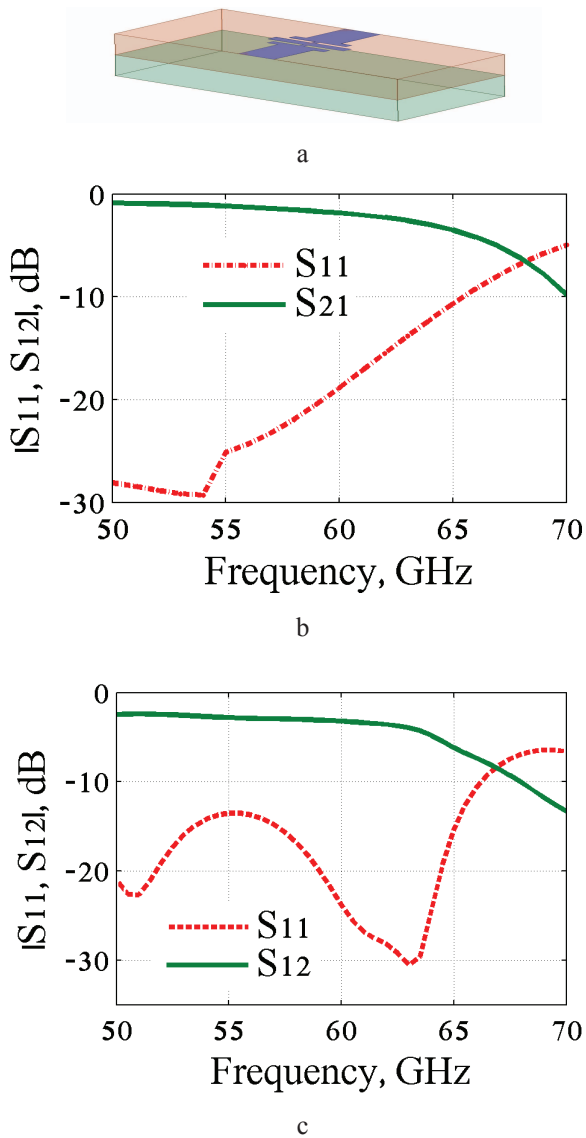

Fig. 5. Simulation using HFSS, a. Distributed element filter, b. S-parameters results (Without transition), c. S-parameters results (With transition)

The simulated insertion losses for the stepped impedance filter with the PGL technology (1.8 dB at 60 GHz), better than the ones with the suspended line technology (2.5 dB at 60 GHz) [6].

IV. MEASUREMENTS

The PGL filter was measured on wafer using 150 μm pitch Ground-Signal-Ground probes and a Vectorial Network Analyzer (VNA) operating up to 67 GHz [9]. A LRM (Line Reflect Match) calibration technique is used to eliminate systematic measurement errors due to the imperfections in the analyzer and test setup. Fig. 6a shows the fabricated stepped impedance low-pass filter under test, (7.35 \times 4.11mm with 2 transitions, 1.357 \times 0.8mm without transition).

Measured S-parameters of the PGL filter with CPW-PGL transitions are compared to the filter with CPW-PGL transitions simulation results in Fig. 6.b, showing a good agreement, with 3.6 dB insertion loss at 60 GHz for both simulation and measurement.

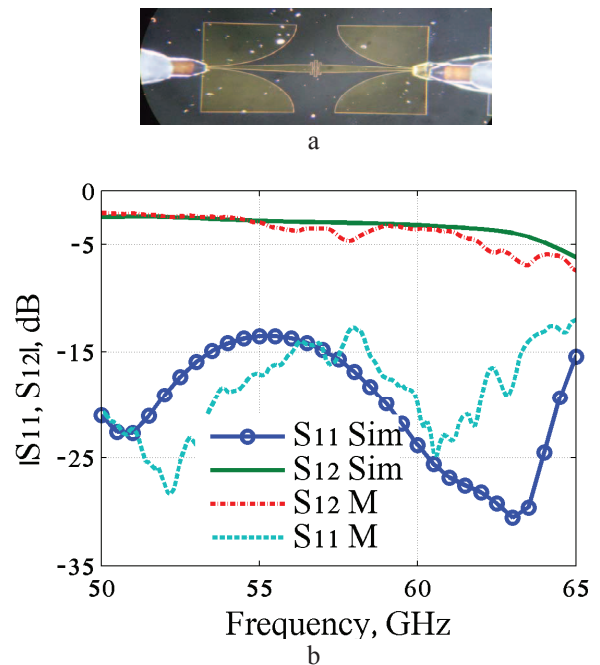

Fig. 6. Measurements, a. Fabricated structure under test, b. Comparison between experimental (M) and simulation (Sim) results

V. CONCLUSION

In this paper, a fifth order stepped impedance low-pass filter with coplanar-PGL transitions have been designed using an easy technology of Planar Goubau Line. The filter offers insertion loss of 3.6 dB at 60 GHz with return loss less than 15 dB up to 62 GHz. These performances show the efficiency of the PGL technology to design filters at 60 GHz. The de-embedding technique would be applied to extract parameters of the filter without transition to compare it with the electrical

and electromagnetic simulated results. In the same manner, the parameters of the transition could be obtained.

REFERENCES

- [1] Daniel Sánchez-Escuderos, Miguel Ferrando-Bataller, Jose I. Herranz, and Marta Cabedo-Fabrés "Periodic Leaky-Wave Antenna on Planar Goubau Line at Millimeter-Wave Frequencies", *IEEE Antennas and Wireless Propagation Letters*, Vol. 12, pp. 1006-1009, 15 august 2013, DOI: 10.1109/LAWP.2013.2278035.
- [2] A.K.Horestani, W. Withayachumnankul, A. Chahadih, A. Ghaddar, M. Zehar, D. Abbott, T. Akalin, and C. Fumeaux " Bandpass Filters Based on Coupled Split Ring Resonators for Surface Waves on Planar Goubau Lines", *The 2014 International Workshop on Antenna Technology*, 2014.
- [3] A. Treizebre, S. Laurette, Y. Xu, R. G. Bosisio and B. Bocquet "THz power divider circuits on planar goubau lines (PGLs)", *Progress In Electromagnetics Research C*, Vol. 26, pp. 219–228, 2012.
- [4] J. Emond, M. Grzeskowiak, S. Protat, G. Lissorgues, F. Deshours, E. Richalot, O. Picon, "A low-loss planar goubau line and a coplanar-pg transition on high-resistivity silicon substrate in the 57–64 GHz band", *Microwave and Optical Technology Letters*, Vol. 54, no. 1, 2012.
- [5] Y. Amano, A. Yamada, E. Suematsu, H. Sato, "Low Cost Planar Filter for 60GHz Applications", *30th European Microwave Conference*, 2000.
- [6] Shah, Sanjeev Kumar, et al. "Design and Development of Low Pass Filter at 60 GHz", *IJECCE* 4.4 (2013): 1245-1247.
- [7] G.L. Mathaei, L. Young & E.M.T. Jones, "Microwave Filter impedance matching networks and coupling structures", *Artech House*, Dedham, Mass, 1980.
- [8] Jia-Shen, Hong, G., & Lancaster, M. J., "Microstrip Filters for RF/Microwave Applications", *John Wiley & Sons Inc.*, 2001.
- [9] <http://www.keysight.com>