



HAL
open science

Experimental Investigations of a Krypton Stationary Plasma Thruster

A. I. Bugrova, A.M. Bishaev, A. V. Desyatskov, M.V. Kozintseva, A. S. Lipatov, M. Dudeck

► **To cite this version:**

A. I. Bugrova, A.M. Bishaev, A. V. Desyatskov, M.V. Kozintseva, A. S. Lipatov, et al.. Experimental Investigations of a Krypton Stationary Plasma Thruster. International Journal of Aerospace Engineering, 2013, pp.686132. 10.1155/2013/686132 . hal-01583309

HAL Id: hal-01583309

<https://hal.sorbonne-universite.fr/hal-01583309v1>

Submitted on 7 Sep 2017

HAL is a multi-disciplinary open access archive for the deposit and dissemination of scientific research documents, whether they are published or not. The documents may come from teaching and research institutions in France or abroad, or from public or private research centers.

L'archive ouverte pluridisciplinaire **HAL**, est destinée au dépôt et à la diffusion de documents scientifiques de niveau recherche, publiés ou non, émanant des établissements d'enseignement et de recherche français ou étrangers, des laboratoires publics ou privés.



Distributed under a Creative Commons Attribution 4.0 International License

Research Article

Experimental Investigations of a Krypton Stationary Plasma Thruster

**A. I. Bugrova,¹ A. M. Bishaev,¹ A. V. Desyatskov,¹ M. V. Kozintseva,¹
A. S. Lipatov,¹ and M. Dudeck²**

¹ *Laboratory of Plasmadynamics, Sub-Faculty of Physics, Moscow State Technical University of Radio Engineering, Electronics and Automation (MSTU MIREA), 119454 Moscow, Russia*

² *Institut Jean le Rond d'Alembert, Université Pierre et Marie Curie (Paris 6), 75252 Paris Cedex, France*

Correspondence should be addressed to M. Dudeck; michel.dudeck@upmc.fr

Received 18 August 2012; Revised 27 December 2012; Accepted 29 January 2013

Academic Editor: I. D. Boyd

Copyright © 2013 A. I. Bugrova et al. This is an open access article distributed under the Creative Commons Attribution License, which permits unrestricted use, distribution, and reproduction in any medium, provided the original work is properly cited.

Stationary plasma thrusters are attractive electric propulsion systems for spacecrafts. The usual propellant is xenon. Among the other suggested propellants, krypton could be one of the best candidates. Most studies have been carried out with a Hall effect thruster previously designed for xenon. The ATON A-3 developed by MSTU MIREA (Moscow) initially defined for xenon has been optimized for krypton. The stable high-performance ATON A-3 operation in Kr has been achieved after optimization of its magnetic field configuration and its optimization in different parameters: length and width of the channel, buffer volume dimensions, mode of the cathode operation, and input parameters. For a voltage of 400 V and the anode mass flow rate of 2.5 mg/s the anode efficiency reaches 60% and the specific impulse reaches 2900 s under A-3 operating with Kr. The achieved performances under operation A-3 with Kr are presented and compared with performances obtained with Xe.

1. Introduction

Hall effect thruster (HET, also named electron drift thrusters or Stationary Plasma Thrusters—SPT or PPS) is currently considered as the most efficient propulsion device for station-keeping of geostationary satellite for telecommunication. In this electrostatic plasma thruster, positive ions are created in an annular channel by inelastic collisions between neutral atoms and electrons emitted by an external hollow cathode. This process requires electron trapping in the channel by a radial magnetic field which is generated by a set of external magnetic coils or by permanent magnets. The ions are accelerated from the thruster by an axial electric field which is generated by a decrease of the electron mobility controlled by the magnetic field. But in the range of values of electron and ion parameters, only the electrons are magnetized (electron Larmor radius \ll channel size \ll ion Larmor radius).

The first electric thruster in space was a FEEP (Field Emission Electric Propulsion) on board the ZOND2 soviet

satellite in 1964 and the first SPT was tested in space in 1972 on the Soviet Meteor meteorological satellite. Now, more than 300 SPTs have been used on-board geostationary satellites for telecommunications. Moreover, a PPS1350 Hall effect thruster from Snecma-Group SAFRAN (France) has been used with success for primary propulsion on the SMART-1 interplanetary mission. This European mission arrived on a Lunar orbit (2003-2004) with only 80 kg of xenon propellant. This very low consumption is due to the high velocity of the ejected ions in HET thruster ($15\text{--}20\text{ km}\cdot\text{s}^{-1}$) giving a high specific impulse and a low propellant mass for a required variation of velocity of the satellite.

Xenon (Xe) as propellant was used for electric thrusters for the Deep Space One, SMART-1 and many geostationary missions. The noble gas xenon (131.3 amu) is chosen for its low potential of first ionization (12.13 eV), ionization cross section ($2.3\cdot 10^{-6}\text{ cm}^2$ from the ground state), its absence of toxicity and its thermodynamics properties for PPU requirements as

possibility to use xenon at a high pressure in the tank ($p_C = 58.4 \text{ bar}$, $T_C = 16.5^\circ\text{C}$).

However, xenon is expensive due to its low amount in Earth's atmosphere (1.14 ppm).

Today, beside purely scientific interest, using different gases as the propellant in stationary plasma thrusters is more economically attractive for interplanetary missions in the solar system [1]. Alternative propellants to xenon, such as atomic gas as Ar or Kr or molecular gas as N_2 or CO_2 , are much cheaper, although they have certain disadvantages: having a smaller atomic mass and higher first ionization potential will result in thruster operating with lesser efficiency than that at Xe. However, the higher specific impulse, the accessibility, and the lower cost of alternative gases are much more advantageous for their using in space in particular for the long term, of the order of tens of thousands of hours of SPT operation for long interplanetary journeys. It is quite really due to the advancement of the current technologies. Thus physical researches carried out in the development of Hall effect thrusters, optimally operating with alternative propellants, are now not only of current importance but necessary as well.

The simple replacement of the propellant in the thruster developed for the operation at Xe does not give positive effect without additional updating of the thruster. Previous experiments have shown that the solely replacement of xenon, for example, onto Ar, N_2 , or CO_2 that is ineffective. It is necessary to make modifications to the discharge chamber and for the thruster's magnetic topography and maybe to use other materials with the required physical properties for the construction. Modernization of the thrusters working with alternative propellants is necessary and it will be different for every concrete gas [1].

The use of krypton instead of xenon has been extensively considered and the properties for several HET have been described in numerous papers [1, . . . , 7]. The main advantages of krypton are found in its mass (83.8 amu) resulting in an ideal high specific impulse (I_{sp}) when compared to xenon (131.3 amu for xenon), its low cost compared to xenon, and its critical values ($p_C = 55.02 \text{ bar}$; $T_C = -63.8^\circ\text{C}$). Disadvantages are its ionization cross section of $1.3 \times 10^{-16} \text{ cm}^2$ results a low propellant utilization (compared to xenon), and reduced I_{sp} , a 14.00 eV energy for the first ionization (greater than xenon). However, all the authors indicate the necessity of an optimisation of the design of the HET for use with krypton in order to compensate for its disadvantages. For this purpose, increases of the channel length, of the number of atoms of krypton, of the mirror electron effect, and of the discharge voltage are suggested and an optimisation of the magnetic field is required.

In Section 2, previous works on SPT running with Kr are briefly presented. They are performed in Russia, USA, Poland, and France. The mean power thruster ATON A-3 developed by MSTU MIREA at Moscow is presented in Section 3. The results of the experiment series for the mean power thruster ATON A-3 (MSTU MIREA, Moscow, Russia) under using krypton and xenon as propellant are described in Section 4.

2. Previous Experimental Works with Krypton

The previous works with SPT working with krypton are briefly reported. With a usual SPT-100 and for several percentages of Xe-Kr mixtures, Kim et al. [2] obtained a reduction of the efficiency up to 15% with pure krypton. An additional coil allowed to optimize the magnetic topology to reach an anode thrust efficiency with pure Kr more than 50%. The authors showed that the increase of specific impulse is lower than expected because of the reduction of the propellant utilization efficiency.

A low power HET (200 W) previously designed for xenon has been adapted to krypton in the Air Force Research Laboratory, AFRL, USA [3]. With xenon operating conditions as reference, an increase of the flow rate of krypton (+24%) and a decrease of the coils current (−50%) have induced for this HET only a small decrease of the anode current (−15%). The discharge properties with krypton exhibit differences on velocity ion distribution and present a similar value of electric field.

A SPT-100 flight model thruster (1,350 W) from Fakel EdB in Russia has been tested in the vacuum chamber of AFRL [4] with a broad range of xenon and krypton mass flow rates at various discharge voltages. For nominal conditions close to the condition giving the same number of atoms (37% less), the thrust is between 20 and 30% less for krypton compared to xenon and the specific impulse is 37% less which is due to a low propellant utilization factor for Kr. An increase of mass flow rate around 23% or an increase of discharge potential at the nominal mass flow rate allows to compensate the low performances of krypton. However, the results have been obtained without magnetic optimization for each operating condition.

Krypton as a propellant has been used with a low power (200 W) to study the change of performances by changing the size of the channel [5]. It is experimentally shown that the propellant utilization factor increases with the channel width and also with the discharge voltage, and its increase is higher for xenon than that for krypton. The ion velocity of Kr^+ obtained by laser-induced fluorescence-(LIF) reveals that an acceleration zone for krypton is some that shifted to the exit of the discharge channel in comparison with Xe as a propellant.

Recently, the Institute of Plasma Physics and Laser Microfusion (IPPLM) at Warsaw manufactured a new HET especially dedicated to krypton [6, 7]. The design is based on previous analysis for HET and also on magnetic and thermal simulations with krypton. This small HET ($D = 50 \text{ mm}$, $L = 12 - 35 \text{ mm}$, $B_{\max} = 250 \text{ G}$) operates with an optimized magnetic field which is defined to limit the electron flux on the inner surfaces of the HET. This thruster is under development at IPPLM.

Instead of these previous researches, experimental measurements and theoretical researches on the physics properties of the krypton plasma discharge inside the channel and the plume of HET are required to deepen its knowledge.

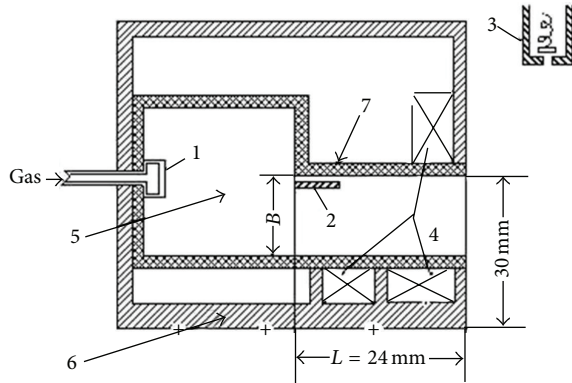

FIGURE 1: Schematic view of the ATON A-3 SPT: (1) gas distributor, (2) anode, (3) cathode-compensator, (4) magnetic coils, (5) buffer volume, (6) magnetic circuit, and (7) dielectric channel; $B = 12$ mm.

3. ATON A-3 (MSTU MIREA, Moscow)

The ATON A-3 thruster is HET developed, manufactured, optimized, and studied in MSTU MIREA under the leadership of Professors Morozov and Bugrova [8–11]. The construction, characteristics, and the principle of the operation of SPT ATON are described in detail in [8]. The ATON A-3 schematic drawing is shown in Figure 1. The annular plasma chamber consists in two successive parts with different diameters: the buffer volume and the accelerator channel. The buffer volume is used in SPT ATON and it is necessary for the most uniform distribution of a propellant. The anode and the gas distributor are separated in a SPT of ATON type: the gas distributor is in the bottom of the buffer and the annular anode is located at the entrance of the accelerator channel. The external diameter of the channel at the chamber exit is 60 mm. The chamber is made of BNSiO_2 . The magnetic field lines configuration in SPT of new generation named ATON provides the focusing condition of ions, and plasma flow is separated from insulator walls. The magnetic field is generated by a set of three external coils (see Figure 1). Due to the equipotentialization of magnetic force lines in SPT [8] one may control the shape of plasma jet changing currents in the coils. If the magnetic force lines are “directed” in radius and have the convexity to the anode (an “ideal” one, [8]) then plasma jet has the shape of the “cylinder” (or a “tube”). The magnetic field is one of the most important parameters to be changed when a HET operates with different gases. The external LaB_6 hollow cathode is also manufactured by MSTU MIREA. The ATON A-3 is a 400 W–1000 W thruster that in operation with the xenon as propellant under the anode mass flow rate of 2.3 mg/s achieves a thrust of 46.6 mN at voltage of (Ud) 350 V and a discharge current of 2.25 A.

Presently, the number of missions, in which SPT can be employed, has considerably extended. In connection with this, the investigations on the optimization of SPT operation, using different propellants, is the most interesting and perspective. The first startups have shown that, for the optimal operation mode (that corresponds to the minimum of the discharge current), current magnitudes in magnetic coils

differ significantly from the currents in coils under operation on xenon, with a jet shape on Kr far from a “cylinder” one on Xe. It means that the magnetic field configuration is significantly far from the “ideal” one [8]. The difference in the geometries of the magnetic field lines for Xe and Kr in the optimal mode is caused by the magnitude of the electron temperature in the accelerator channel, because

$$V^*(\gamma) = V - \frac{k_B T_e(\gamma)}{e} \cdot \ln \frac{n}{n_0}, \quad (1)$$

where V^* is constant potential along the B field lines, k_B is Boltzmann constant, e is the elementary charge, n is the plasma density and n_0 is a reference density, and T_e is the electron temperature [11]. One may see from this expression that the smaller the electron temperature, the closer the shape of the equipotential lines, determining a jet shape, to the shape of magnetic force lines. According to measured local plasma parameters in the ATON A-3 accelerator channel [10], the electron temperature in the ionization region for Kr is lower than that for Xe. This fact significantly promotes a choice of the magnetic field geometry under the operation on Kr. The optimization of the magnetic field has been carried out by the optimization of the magnetic circuit of the thruster. As a result, the optimized magnetic field differs from the distribution of the force lines in the volume of the accelerative channel and by the increased gradient of the radial magnetic field B_r in comparison with operation in xenon.

Then the experiments have been carried out in order to optimize ATON A-3 in the channel width and length and buffer volume dimensions and also in order to optimize the mode of the cathode operation, that is, in the mass flow rate through it, its input power and its location relative to the thruster outlet (the same cathode from MIREA, which was used during Xe tests, was also used for Kr). (The concrete values of all these parameters depend of the concrete model of used SPT and must be selected experimentally for every used SPT model.) Our purpose during all optimization experiments was obtaining the maximal anode efficiency of the thruster.

All tests have been performed in MIREA vacuum chamber with the diameter ~ 1 m and with the length ~ 3 m. Its pumping system consists of four high-pressure vacuum pumps with capacity 20 l/s for everyone and three diffusive pumps with capacity 7000 l/s (in respect to air) for everyone, which provided initial vacuum $\sim 3 \cdot 10^{-5}$ mm Hg (in respect to air) and dynamic vacuum $\sim 2 \cdot 10^{-4}$ mm Hg (in respect to air) at Kr total mass flow rate 2.5 mg/s. The test stand was provided with the torsion three filaments balance with the laser indicator in order to measure the thrust. The deviation of the laser beam is measured after its reflection at a distance of 3 m. The balance accuracy was equal to $\leq 3\%$.

4. Performances of the ATON A-3

Using optimized (in channel width, etc.—see Section 3) ATON A-3 model, the experiments have been carried out in order to investigate its performances in a wide range of input parameters under its operation with krypton. The operation

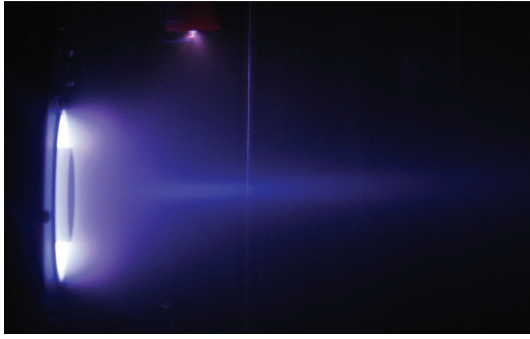
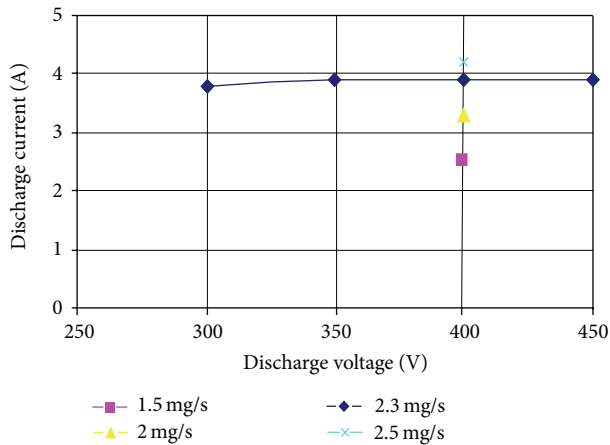

FIGURE 2: ATON A-3 running with krypton.

FIGURE 3: ATON A-3 discharge current versus discharge voltage under $\dot{m}_a = 2.3 \text{ mg/s}$ and for different Kr anode mass flow rates under $U_d = 400 \text{ V}$.

of the ATON A-3 in Kr is shown in Figure 2. The obtaining of the maximal anode efficiency under ATON A-3 operation with Kr has been the criterion of the choice of the optimal input parameters. In these experiments, the propellant mass flow rate was varied from 1.5 mg/s to 2.5 mg/s. The cathode operated in the optimal mode, obtained during optimization experiments, which corresponded to $\dot{m}_{\text{cathode}}/\dot{m}_{\text{anode}} \approx 26\%$. This ratio was kept constant when the anode mass flow rate is changed. The discharge voltage was varied from 300 V to 500 V. The power, input in the accelerator, was the limitation of the mass flow rate and discharge voltage increase.

The results of measuring of the integral parameters are represented in Figures 3, 4, 5, and 6. As it is seen from Figure 3, the discharge current is quite constant for the voltage range from 300 V to 450 V for the constant anode mass flow rate of 2.3 mg/s that indicates the high degree of ionization of the propellant. For a discharge voltage of 400 V, the current is increasing from 2.5 A to 4.2 A for a Kr anode mass flow rate increasing from 1.5 mg/s to 2.5 mg/s as shown in Figure 3.

In Figure 4, the discharge current is compared to the current obtained if all the atoms of Kr are ionized (so named

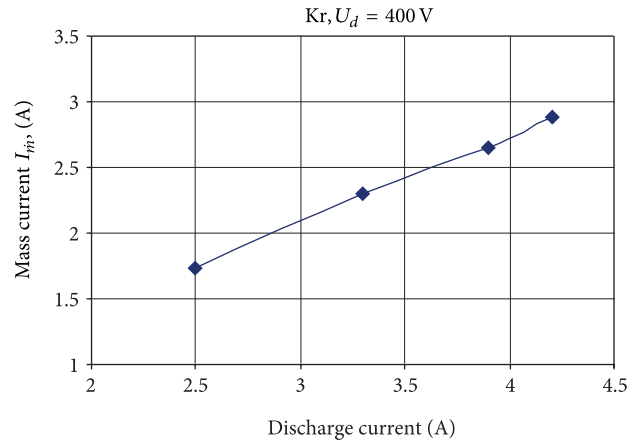
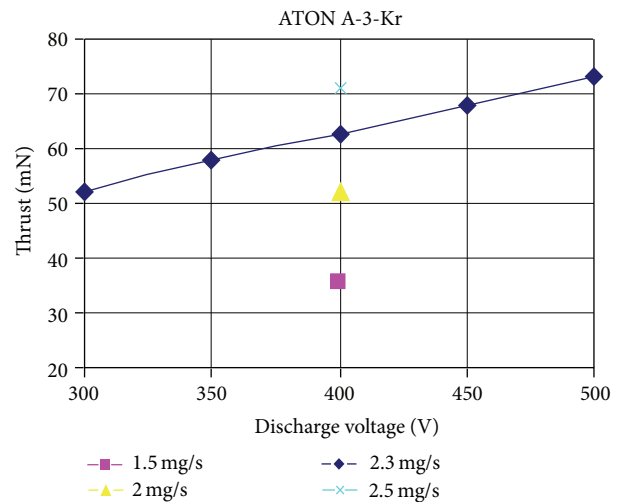
FIGURE 4: ATON A-3 mass current I_m versus discharge current for U_d of 400 V in operation on Kr.FIGURE 5: ATON A-3 thrust versus discharge voltage under $\dot{m}_a = 2.3 \text{ mg/s}$ and for different Kr anode mass flow rates under $U_d = 400 \text{ V}$.

mass current I_m , $I_m = e \cdot \dot{m}/M_{\text{Kr}}$, where M_{Kr} is mass of Kr atom). As it is seen from Figure 4, the discharge current significantly exceeds the mass current for Kr as a propellant. However, when Xe is used as a propellant in the discharge voltage range $250 \text{ V} \leq U_d \leq 400 \text{ V}$, the discharge current either is equal to the mass current or slightly exceeds its value. The difference between I_d and I_m takes place due to the presence of the certain part of doubly ionized atoms and of "transit" electron current [10].

In Figure 5, the evolution of the A-3 thrust is shown for the discharge voltage range from 300 V to 500 V at constant Kr anode mass flow rate (2.3 mg/s) and also for different Kr anode mass flow rates from 1.5 mg/s to 2.5 mg/s for a discharge voltage of 400 V. It is seen from Figure 5 that the thrust is proportional to the discharge voltage in its range for a constant anode mass flow rate of 2.3 mg/s. For

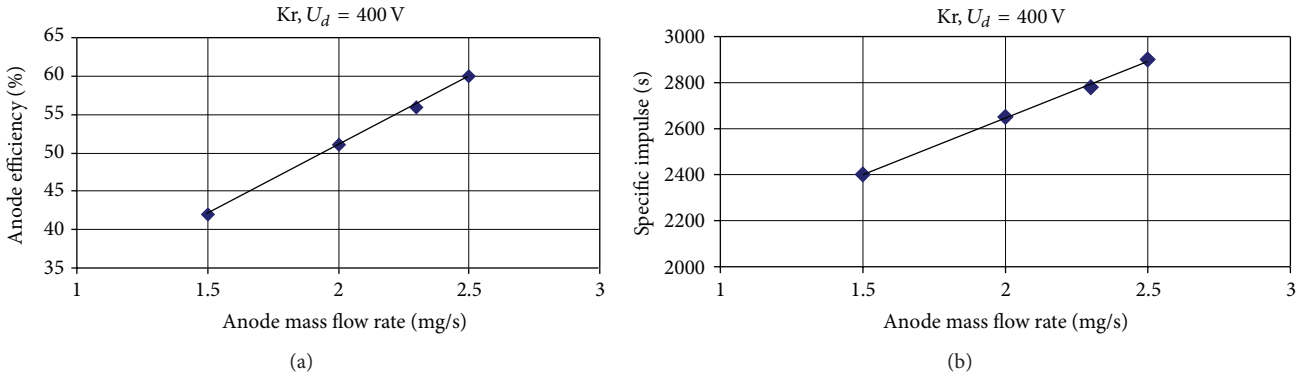

FIGURE 6: ATON A-3 (a) anode efficiency and (b) specific impulse versus Kr anode mass flow rate under $U_d = 400$ V.

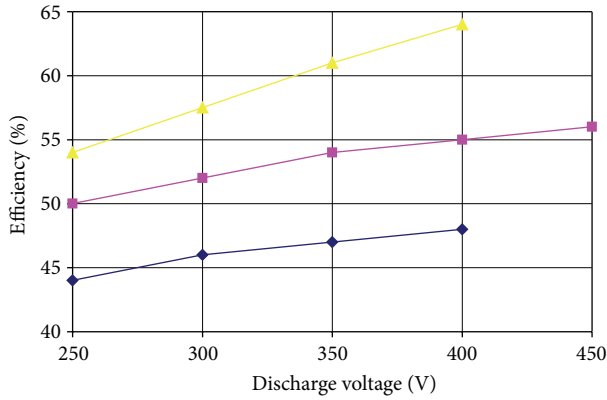

FIGURE 7: ATON A-3 anode efficiency versus discharge voltage for propellant anode mass flow rate of 2.3 mg/s: operation on Xe (yellow triangle ▲); operation on Kr (purple square ■), optimized model; operation on Kr (blue diamond ◆), non optimized model.

a discharge voltage of 400 V, the thrust is increasing from 35.3 mN to 71.1 mN for a Kr anode mass flow rate increasing from 1.5 mg/s to 2.5 mg/s.

The dependences of ATON A-3 anode efficiency and specific impulse versus Kr anode mass flow rate under $U_d = 400$ V are represented in Figures 6(a) and 6(b), respectively. The anode efficiency is linearly increasing from 42% to 60% (see Figure 6(a)) and also specific impulse is linearly increasing from 2400 s to 2900 s (see Figure 6(b)) when the anode mass flow rate varies from 1.5 mg/s to 2.5 mg/s for a voltage of 400 V.

As it is known, the physical processes in SPT are determined by three fundamental characteristics of the operation process [9]: the coefficient of the loss of the applied voltage ($1 - \chi = 1 - \Delta U/U_d$, where ΔU is the consumption of energy for ionization and different losses), the propellant using efficiency ($\mu = I_i/I_{\dot{m}}$, where I_i is the ion current in the channel exit and $I_{\dot{m}}$ is the mass current), and the change parameter ($\xi = I_d/I_{\dot{m}}$). From an extensive study of the thruster's performances in Kr [9, 10], it turned out that a

same-sized thruster works in the same modes (same ξ , μ , and χ parameters) for the same mass flow rates of the different propellants.

Therefore, in Figures 7 and 8, we compare ATON A-3 performances obtained with Kr and Xe at the same mass flow rate equal to 2.3 mg/s. The range of discharge voltages is $250 \text{ V} \leq U_d \leq 500 \text{ V}$. As it is seen from Figure 7, the optimization allowed to increase the anode efficiency of thruster by ~7% for the discharge voltage range $250 \text{ V} \leq U_d \leq 400 \text{ V}$.

As it is seen from Figure 8(a) for the two gases, the discharge current depends only slightly on the discharge voltage in the studied range of 250 V to 400 V and the ratio $I_d(\text{Kr})/I_d(\text{Xe})$ is constant and with a value around 1.6. This fact indicates that for both Xe and Kr, we have the high degree of ionization of the propellant. The level of the discharge current oscillations in the frequency range 1–300 kHz is $\bar{I}/\bar{I} \leq (10\text{--}20)\%$ for both propellants.

The results of the thrust measurements for the same anode mass flow rate 2.3 mg/s at $250 \text{ V} \leq U_d \leq 400 \text{ V}$ for Xe and at $300 \text{ V} \leq U_d \leq 500 \text{ V}$ for Kr are represented in Figure 8(b). At the same mass flow rate, the thrust on krypton is greater than that on xenon and the ratio of the thrusts at the same discharge voltage is about 1.23–1.25. If in the first approximation one assumes that the singly charged ions of Xe and Kr in SPT are accelerated by the same discharge voltage, the ratio of the ion velocities for krypton and xenon is expressed as $V_i(\text{Kr})/V_i(\text{Xe}) = \sqrt{m_i(\text{Xe})/m_i(\text{Kr})} = 1.25$. The ion velocity of krypton is greater than xenon due to its lower mass. As a consequence, the thrust ratio of both propellants is around 1.25, provided that their ionization degrees are high enough, and in the same magnitude.

The anode efficiency η_a , obtained under ATON A-3 operation with Xe and Kr at the same mass flow rate 2.3 mg/s, is plotted in Figure 8(c). The anode efficiency with xenon is always greater than the efficiency with krypton. For optimized ATON A-3 thruster, the anode efficiency reaches 55% for the discharge voltage of 400 V and the anode mass flow rate of 2.3 mg/s. But the anode efficiency measured with Xe at the same discharge voltage for the anode mass flow rate 2.3 mg/s is equal to 64%. This difference is mainly the

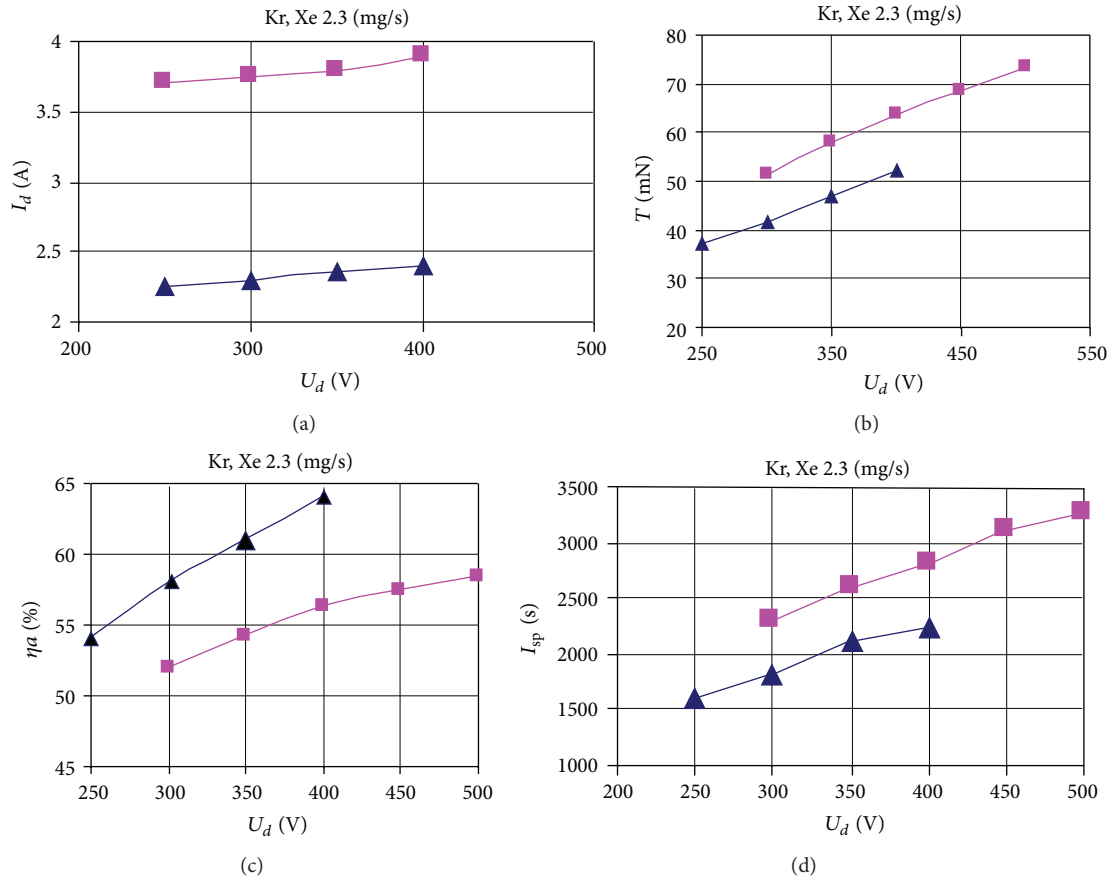

FIGURE 8: ATON A-3 (a) current-voltage characteristics of the discharge and the dependences of (b) the thrust, (c) anode efficiency, and (d) specific impulse on the discharge voltage at the anode mass flow rate of 2.3 mg/s in operation on Kr, optimized model (purple square ■), and Xe (blue triangle ▲).

consequence of the fact that the ionization losses for Xe are lower than those for Kr due to the higher level of the first ionisation of Kr.

The specific impulse as a function of the discharge voltage for Kr and Xe at the same mass flow rate 2.3 mg/s is shown in Figure 8(d). The specific impulse with krypton is always greater than the specific impulse with xenon. It is explained by the higher velocity of the plasma flow under operation with Kr (due to its lower mass).

Thus, in the operation ATON A-3 with Kr, the positive factors (the advantages) are the bigger thrust and the higher specific impulse under the same mass flow rate. Besides, today the cost of Kr is two times less than that of Xe. However, for Kr operation, it is necessary to input higher power and the thruster efficiency slightly decreases.

5. Conclusion

The stable high performances of HET ATON A-3 operation in Kr have been achieved after optimization of its magnetic field configuration and its optimization in different parameters: length and width of the channel, buffer volume dimensions, mode of the cathode operation, and input parameters. At the same (as for Xe) mass flow rate of the propellant, the specific impulse and the thrust for Kr operation are greater than those

for Xe. The efficiency of a thruster operating with krypton is lower than the efficiency at its operation with xenon. This is explained by the higher energy cost of an ion for Kr due to its higher ionization energy. However, krypton as a propellant is attractive because of its cost. These results have been obtained due to the using of scaling law [9, 10]: a thruster of the same dimensions will operate with the different gases in the same modes from the physics point of view under the same mass flow rates.

Acknowledgments

The French research is partially performed in the frame of the French research Group GDR3161 CNRS/CNES/Snecma/Universités "Propulsion par plasma dans l'espace." The Russian study was supported by the Ministry of Education and Science of Russian Federation and under the partial support of INTAS-99-1225. A. S. Lipatov one of the authors, died in 2012.

References

- [1] A. Kieckhafer and L. B. King, "Energetics of propellant options for high-power Hall thrusters," in *Proceedings of the Space Nuclear Conference*, 2011.

- [2] V. Kim, G. Popov, V. Kozlov, A. Skrylnikov, and D. Grdlikhko, "Investigation of SPT performances and particularities of its operation with Kr/Xe mixtures," in *Proceeding of the 27th International Electric Propulsion Conference (IEPC '01)*, 2001, AIAA 96-2969.
- [3] W. A. Hargus, G. M. Azarnia, and M. R. Nakles, "Demonstration of laser-induced fluorescence on a krypton Hall effect thruster," in *Proceedings of the 32nd International Electric Propulsion Conference (IEPC '01)*, IEPC-2011-018, Wiesbaden, Germany, September 2011.
- [4] M. R. Nakles, W. A. Hargus, J. J. Delgado, and R. L. Corey, "A comparison of xenon and krypton propellant on an SPT-100 Hall thruster," in *Proceedings of the 32nd International Electric Propulsion Conference (IEPC '01)*, IEPC-2011-003, p. 15, Wiesbaden, Germany, September 2011.
- [5] S. Mazouffre, K. Dannenmayer, G. Bourgeois, and A. Lejeune A, "Performances of a variable channel width Hall thruster operating with Xenon and Krypton," in *Proceedings of the Space Propulsion Conference (SP '12)*, pp. 7–10, Bordeaux, France, May 2012.
- [6] J. Kurzyna and D. Danilko, "IPPLM Hall effect thruster—design guidelines and preliminary tests," in *Proceedings of the 32nd International Electric Propulsion Conference*, IEPC-2011-221, pp. 11–15, Wiesbaden, Germany, September 2011.
- [7] ScienceDaily, Krypton Hall Effect Thruster for Spacecraft Propulsion, <http://www.sciencedaily.com/releases/2011/10/111006084023.htm>.
- [8] A. I. Morozov, A. I. Bugrova, and A. V. Desyatskov, "ATON-thruster plasma accelerator," *Plasma Physics Reports*, vol. 23, no. 7, pp. 587–597, 1997.
- [9] A. I. Bugrova, A. S. Lipatov, A. I. Morozov, and D. V. Churbanov, "On a similarity criterion for plasma accelerators of the stationary plasma thruster type," *Technical Physics Letters*, vol. 28, no. 10, pp. 821–823, 2002.
- [10] A. I. Bugrova, A. S. Lipatov, A. I. Morozov, and L. V. Solomatina, "Global characteristics of an ATON stationary plasma thruster operating with krypton and xenon," *Plasma Physics Reports*, vol. 28, no. 12, pp. 1032–1037, 2002.
- [11] A. I. Bugrova, A. V. Desyatskov, A. S. Lipatov et al., "Experimental study of ATON stationary plasma thrusters," *Plasma Physics Reports*, vol. 36, no. 4, pp. 365–370, 2010.



Hindawi

Submit your manuscripts at
<http://www.hindawi.com>

