

## Preclinical In Vivo Evaluation of the Safety of a Multi-shRNA-based Gene Therapy Against HIV-1

Mireille Centlivre, Nicolas Legrand, Sofieke Klamer, Ying Poi Liu, Karin Jasmijn Von Eije, Martino Bohne, Esther Siteur-Van Rijnstra, Kees Weijer, Bianca Blom, Carlijn Voermans, et al.

► **To cite this version:**

Mireille Centlivre, Nicolas Legrand, Sofieke Klamer, Ying Poi Liu, Karin Jasmijn Von Eije, et al.. Preclinical In Vivo Evaluation of the Safety of a Multi-shRNA-based Gene Therapy Against HIV-1. *Molecular Therapy - Nucleic Acids*, Nature Publishing Group, 2013, 2, <10.1038/mtna.2013.48>. <hal-01584076>

HAL Id: hal-01584076

<https://hal.sorbonne-universite.fr/hal-01584076>

Submitted on 8 Sep 2017

**HAL** is a multi-disciplinary open access archive for the deposit and dissemination of scientific research documents, whether they are published or not. The documents may come from teaching and research institutions in France or abroad, or from public or private research centers.

L'archive ouverte pluridisciplinaire **HAL**, est destinée au dépôt et à la diffusion de documents scientifiques de niveau recherche, publiés ou non, émanant des établissements d'enseignement et de recherche français ou étrangers, des laboratoires publics ou privés.



# Preclinical *In Vivo* Evaluation of the Safety of a Multi-shRNA-based Gene Therapy Against HIV-1

Mireille Centlivre<sup>1,6</sup>, Nicolas Legrand<sup>2,7</sup>, Sofieke Klamer<sup>3</sup>, Ying Poi Liu<sup>1</sup>, Karin Jasmijn von Eije<sup>1</sup>, Martino Bohné<sup>2</sup>, Esther Siteur-van Rijnstra<sup>4</sup>, Kees Weijer<sup>2,4</sup>, Bianca Blom<sup>2</sup>, Carlijn Voermans<sup>3</sup>, Hergen Spits<sup>2,5</sup> and Ben Berkhout<sup>1</sup>

Highly active antiretroviral therapy (HAART) has significantly improved the quality of life and the life expectancy of HIV-infected individuals. Still, drug-induced side effects and emergence of drug-resistant viral variants remain important issues that justify the exploration of alternative therapeutic options. One strategy consists of a gene therapy based on RNA interference to induce the sequence-specific degradation of the HIV-1 RNA genome. We have selected four potent short hairpin RNA (shRNA) candidates targeting the viral capsid, integrase, protease and *tat/rev* open-reading frames and screened the safety of them during human hematopoietic cell development, both *in vitro* and *in vivo*. Although the four shRNA candidates appeared to be safe *in vitro*, one shRNA candidate impaired the *in vivo* development of the human immune system in Balb/c Rag2<sup>-/-</sup>IL-2R $\gamma_c$ <sup>-/-</sup> (BRG) mice. The three remaining shRNA candidates were combined into one single lentiviral vector (LV), and safety of the shRNA combination during human hematopoietic cell development was confirmed. Overall, we demonstrate here the preclinical *in vivo* safety of a LV expressing three shRNAs against HIV-1, which is proposed for a future Phase I clinical trial.

*Molecular Therapy—Nucleic Acids* (2013) 2, e120; doi:10.1038/mtna.2013.48; published online 3 September 2013

**Subject Category:** siRNAs, shRNAs, and miRNAs

## Introduction

HIV-1 and AIDS remains as a major public health problem with more than 34 millions infected individuals worldwide in 2011. The development of highly active antiretroviral therapy (HAART) has dramatically reduced both mortality and morbidity, and improved life expectancy and quality of life of the treated individuals. Despite its success, HAART does not fully suppress viral replication, especially in some critical sites (e.g., gut),<sup>1</sup> and allows the persistence of a latent viral reservoir.<sup>2,3</sup> The efficacy of HAART relies on daily adherence to drug regimens, but this life-long treatment is associated with side effects and emergence of drug-resistant viral variants, therefore promoting the search for alternative therapeutic options.

Among these, gene therapy has emerged as new therapeutic option. Ideally, such a gene therapy approach should target the CD34<sup>+</sup> human hematopoietic progenitor cells (hHPC), allowing the generation of a HIV-resistant multilineage immune system with constant supply of HIV-resistant cells that will colonize the blood and tissues. Such approaches were reinforced by the recent clinical success described for the “Berlin patient”. In early 2007, a HIV-positive individual with acute myeloid leukemia received a compatible CD34<sup>+</sup> hHPC transplant from one of the rare individuals who are naturally resistant to HIV-1 (CCR5 $\Delta$ 32) in an effort to eradicate both diseases at once.<sup>4</sup> The patient was declared “functionally cured” as no sign of viral replication was found even 3–4

years after cessation of HAART.<sup>5</sup> Although successful, this approach is impractical for widespread use due to the difficulty of finding suitable CCR5-negative donors and the high risk of the required whole body irradiation.

To circumvent allogeneic transplantation, *ex vivo* modification of individuals own hHPC have been proposed, using new antiviral gene therapy approaches based on RNA interference (RNAi).<sup>6–8</sup> Gene silencing through RNAi can be induced by expression of double-stranded RNA that will lead to sequence-specific degradation of the target RNA.<sup>9</sup> Anti-HIV-1 short hairpin RNA (shRNA) expression in CD4<sup>+</sup> T cells strongly inhibits HIV-1 replication *in vitro*.<sup>10,11</sup> The shRNA-expressing gene cassettes are delivered to autologous hHPC via transduction with a lentiviral vector (LV), which stably integrates into the host genome. There is growing evidence from longitudinal studies in patients that LV can be used safely without signs of abnormal cell expansion induced by vector integration-mediated activation of proto-oncogenes.<sup>12</sup>

To study safety issues of gene therapy approaches, mouse models of the human immune system (HIS) have been used.<sup>11,13,14</sup> Over the last two decades, several humanized mouse models have been generated and optimized for the experimental study of HIS development and function.<sup>15–17</sup> We and others have transplanted CD34<sup>+</sup>CD38<sup>-</sup> hHPC into immunodeficient newborn mice, such as BALB/c Rag2<sup>-/-</sup>IL-2R $\gamma_c$ <sup>-/-</sup> (BRG) or NOD.scid IL-2R $\gamma_c$ <sup>-/-</sup> (NSG) mice, resulting in the development of a multilineage HIS *in vivo*.<sup>18–20</sup> Since target

The first two authors contributed equally to the work.

<sup>1</sup>Department of Medical Microbiology, Laboratory of Experimental Virology, Center for Infection and Immunity Amsterdam (CINIMA), Academic Medical Center, University of Amsterdam, Amsterdam, the Netherlands; <sup>2</sup>Department of Cell Biology & Histology, Center for Immunology of Amsterdam (CIA), Academic Medical Center, University of Amsterdam, Amsterdam, the Netherlands; <sup>3</sup>Department of Hematopoiesis, Sanquin Research and Landsteiner Laboratory, Academic Medical Center, University of Amsterdam, Amsterdam, the Netherlands; <sup>4</sup>HIS mouse facility, Academic Medical Center, University of Amsterdam, Amsterdam, the Netherlands; <sup>5</sup>Tytgat Institute of Intestinal and Liver Research, Academic Medical Center, University of Amsterdam, Amsterdam, the Netherlands; <sup>6</sup>Laboratory of Immunity and Infection, Institut National de la Santé et de la Recherche Médicale, INSERM UMR-S 945, and Université Pierre et Marie Curie, UPMC Univ Paris 06, 91 Bld de l'Hôpital, 75013 Paris, France; <sup>7</sup>AXENIS, 28 rue du Docteur Roux, 75015 Paris, France. Correspondence: Ben Berkhout, Department of Medical Microbiology, Laboratory of Experimental Virology, Center for Infection and Immunity Amsterdam (CINIMA), Room K3-110, AMC-UvA, Meibergdreef 15, 1105 AZ Amsterdam, The Netherlands. E-mail: b.berkhout@amc.uva.nl

**Keywords:** combinational RNA; gene therapy; HIV-1; humanized mouse model; RNA interference

Received 8 March 2013; accepted 24 June 2013; advance online publication 3 September 2013. doi:10.1038/mtna.2013.48

cells for HIV-1 infection are present in the HIS mice, such animal models have become popular for assessing human pathogenesis<sup>21–23</sup> and addressing new HIV therapeutic strategies.<sup>24,25</sup> Considering a future RNAi-based gene therapy approach in the clinic, CD34<sup>+</sup> hHPC would be exposed *ex vivo* to LV and reinfused into the patient, where they would home to the bone marrow and produce mature hematopoietic cells that are protected against HIV-1 infection. Thus, generating HIS mice with genetically engineered hHPC for the expression of anti-HIV shRNA is likely to represent a sensitive safety screen for human hematopoiesis consistent with the envisioned clinical strategy.

In this study, we have selected four shRNA candidates targeting conserved regions of the viral genome for the development of the combinatorial shRNA-based gene therapy against HIV-1. These four shRNA were first tested individually in HIS mice and the safe shRNAs were combined into a single LV that was evaluated for antiviral activity *in vitro* and for safety in HIS mice.

## Results

### Selection of effective anti-HIV-1 shRNAs targeting highly conserved HIV-1 regions

We have previously identified 21 shRNAs targeting eight highly conserved regions of the HIV-1 genome that exhibit potent inhibition of HIV-1 replication.<sup>10</sup> Based on long-term *in vitro* culture experiments, we selected the four most effective shRNAs.<sup>26–28</sup> shGag5, shPol1, shPol47, and shR/T5, respectively targeting the viral capsid, integrase, protease, and *tat/rev* open-reading frames (Figure 1a). The respective four shRNA cassettes were cloned individually in a self-inactivating LV (Figure 1b).

### No signs of toxicity of shRNA expression in a human colony-forming cell assay

We first evaluated the safety of the four shRNAs by performing a human colony-forming cell assay (hCFC). This *in vitro* assay is commonly employed for determining the colony- and burst-forming capacity of hematopoietic progenitor cells and is widely used for measurement of drug toxicity on human hematopoietic progenitor cells (hHPC). We transduced CD34<sup>+</sup>CD38<sup>-</sup> hHPC with the different LVs expressing a single shRNA candidate or the empty control vector JS1. Transduced GFP<sup>+</sup> hHPC were isolated by fluorescence-activated cell sorting and cultured for 2 weeks in the appropriate conditions driving development of colony-forming unit-granulocytes-macrophages (CFU-GM), colony-forming unit-granulocytes-erythroid-macrophages-megakaryocytes (CFU-GEMM) and burst-forming unit-erythroid (BFU-E) (Figure 2a).

CFU-GM, CFU-GEMM, and BFU-E were then counted in four independent experiments. For all the different LV conditions analyzed, transduced hHPC gave rise to the three types of colony/BFU. We counted between 13 and 54 CFU-GM, 5 and 16 BFU-E and 0 and 4 CFU-GEMM for all the conditions analyzed, with high variability between the experiments and between the LV conditions tested, which likely reflects the interdonor hHPC variability. Still, the LV-transduced hHPC – encoding a single or no shRNA candidate – generated comparable numbers of CFU-GM, BFU-E, and CFU-GEMM (Figure 2b–d), indicating no obvious toxicity of shRNA expression on the CFU/BFU

capacity of CD34<sup>+</sup> human hematopoietic progenitor cells in this relatively short-term *in vitro* assay.

### *In vivo* monitoring of the shRNA candidates reveal some toxicity for shGag5 during human hematopoiesis

We next assessed the *in vivo* safety of single shRNA treatment in the humanized BRG-HIS mouse model.<sup>18,19</sup> CD34<sup>+</sup>CD38<sup>-</sup> hHPC were transduced with LVs expressing a single shRNA or the empty control LV prior to xenograft transplantation in immunodeficient BRG newborn mice.<sup>29</sup> The BRG mice were injected with the bulk of cultured hHPC, i.e., they received a mixture of transduced and nontransduced hHPC, providing for each animal an internal control for human immune system development and maturation. An aliquot of the transduced hHPC was kept in culture *in vitro* for 3–4 days to determine the transduction efficiency based on GFP expression.

BRG-HIS mice were killed between 10 and 13 weeks post-hHPC transplantation and we first analyzed the absolute human cell number in the blood and the lymphoid organs (bone marrow, thymus, spleen, and liver) of the animals. Similar numbers of human cells were detected in all the analyzed organs of BRG-HIS mice transplanted with shRNA-transduced hHPC as compared with the control JS1 group (Table 1). This highlights that all four shRNA treatments do not have a negative impact on human hematopoiesis at a global level.

We next monitored the relative frequency of shRNA-transduced hematopoietic cells (GFP<sup>+</sup> hCD45<sup>+</sup> cells). The *in vivo* frequency of human GFP<sup>+</sup> cells in the blood and lymphoid organs of the animals was measured and compared with the original *in vitro* transduction efficiency (Figure 3a). An *in vivo/in vitro* GFP<sup>+</sup> ratio around 1.0 indicates no selection bias with a good recovery of human GFP<sup>+</sup> cells in the animals as compared with the initial transduction efficiency. We observed a similar efficient GFP<sup>+</sup> recovery in the analyzed organs of the BRG-HIS mice that received hHPC expressing shPol1, shPol47, or shR/T5 (Figure 3b–f). In contrast, shGag5 expression appeared to be detrimental for the recovery of human GFP<sup>+</sup> cells *in vivo* in all lymphoid organs,

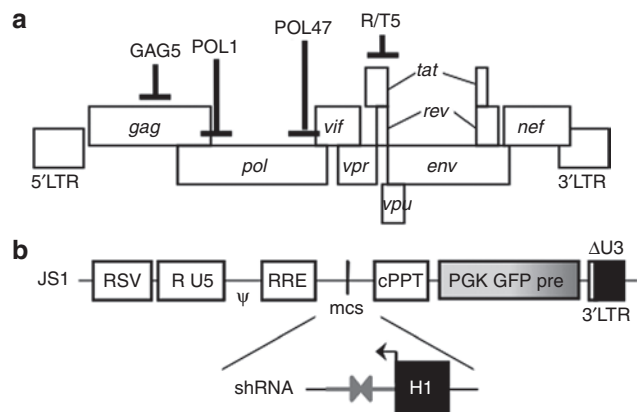

**Figure 1** Anti-HIV-1 shRNA target regions and cloning strategy. (a) The shGag5, shPol1, shPol47, and shR/T5 target positions within the HIV-1 genome are indicated. (b) The third generation self-inactivating lentiviral vector JS1 expresses the green fluorescent protein (GFP) reporter. Single shRNA vectors express in addition a shRNA targeting the HIV-1 genome from the human polymerase III H1 promoter.

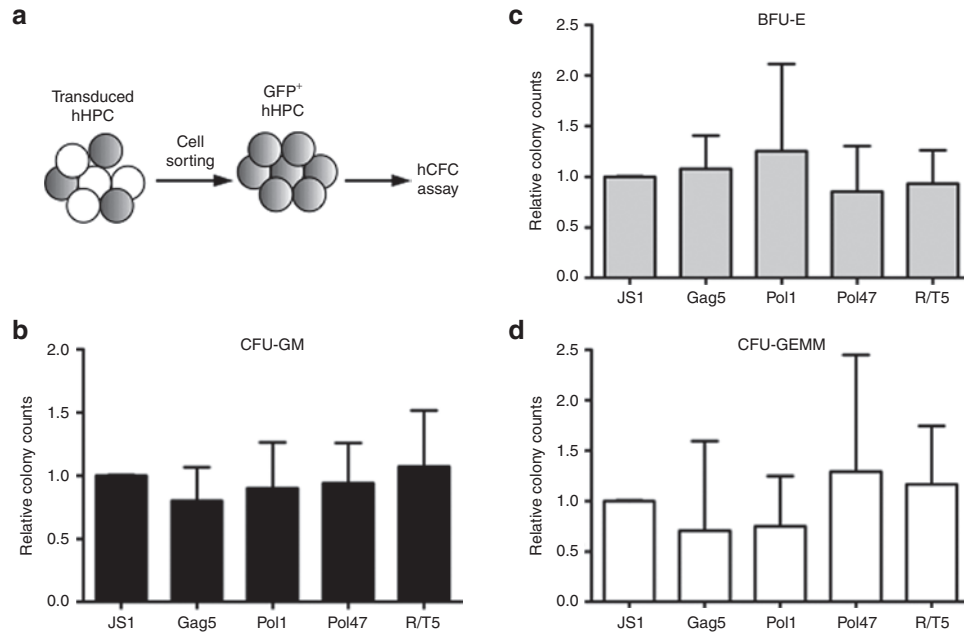

**Figure 2** Impact of *in vitro* shRNA expression in early human hematopoietic progenitors. (a) Human fetal liver CD34<sup>+</sup>CD38<sup>-</sup> hHPC were transduced with JS1, shGag5, shPol1, shPol47, or shR/T5-expressing lentiviral vector. Transduced (GFP<sup>+</sup>) hHPC were sorted and a human colony-forming cell assay was performed. (b–d) Graphs show the relative colony counts of CFU-GM (b), BFU-E (c), and CFU-GEMM (d), as compared with the control JS1 LV. The results (mean ± SD) are pooled from four independent experiments with duplicates for each experiment.

**Table 1** Absolute number of human CD45<sup>+</sup> cells in the organs of shRNA-expressing BRG-HIS mice

|         | Bone marrow (×10 <sup>5</sup> ) | Thymus      | Spleen      | Liver     | Blood (cells/ml) |
|---------|---------------------------------|-------------|-------------|-----------|------------------|
| JS1     | 47.2 ± 31.4                     | 14.7 ± 10.3 | 21.1 ± 18.6 | 5.2 ± 3.4 | 1.53 ± 1.86      |
| shGag5  | 25.4 ± 21.6                     | 10.1 ± 3.2  | 8.5 ± 6.0   | 4.8 ± 2.5 | 0.91 ± 0.53      |
| shPol1  | 72.4 ± 56.8                     | 16.3 ± 10.9 | 39.0 ± 25.5 | 5.7 ± 2.6 | 8.22 ± 14.70     |
| shPol47 | 34.9 ± 18.9                     | 14.4 ± 10.9 | 16.5 ± 14.0 | 5.1 ± 2.9 | 0.71 ± 0.35      |
| shR/T5  | 41.9 ± 38.5                     | 9.1 ± 6.2   | 18.5 ± 15.0 | 4.8 ± 2.5 | 1.17 ± 1.40      |

BRG-HIS mice generated with LV-transduced hHPC for the expression of shGag5 (*n* = 5), shPol1 (*n* = 9), shPol47 (*n* = 17) or shR/T5 (*n* = 11) were analyzed 10–13 weeks post-hHPC transplantation for absolute number of human CD45<sup>+</sup> cells and compared with control animals (empty JS1-transduced hHPC; *n* = 26). Bone marrow analysis was performed on two femurs per animal.

suggesting a negative impact of this specific shRNA on the development of the transduced human hematopoietic cells.

We further analyzed the GFP expression in several human leukocyte subsets of the spleen of BRG-HIS mice, namely human T cells, B cells, monocytes, and pDC (Figure 4a). Good GFP recovery with a ratio around 1.0 was observed for all human cell subsets in JS1 control BRG-HIS mice, but with high variation between the individual animals, especially in the T-cell compartment (Figure 4b). In contrast, all human GFP<sup>+</sup> cell subsets were negatively affected in shGag5-expressing BRG-HIS mice (Figure 4c). The other shRNAs (shPol1, shPol47, and shR/T5) did not affect the recovery of human B cells, monocytes, and pDC (Figure 4d–f). For shPol1- and shR/T5-expressing animals, but not shPol47, a lower recovery of human GFP<sup>+</sup> T cells was observed (Figure 4d–f). Overall, these observations allowed us to formally exclude

shGag5 as a potential anti-HIV-1 shRNA candidate, due to its long-term, negative impact on human hematopoiesis *in vivo*.

#### Delayed seeding of HIS mice thymus by shPol47-expressing human progenitor cells

Reduced accumulation of shRNA-expressing T cells was noticed in 10–13-week old BRG-HIS mice as compared with control LV-transduced T cells, except for shPol47. Still, we questioned whether shPol47-expressing hHPC also showed hindered capacity for T-cell generation at earlier time points, i.e., during early events of BRG-HIS mouse thymus colonization and human T-cell differentiation. We transduced CD34<sup>+</sup>CD38<sup>-</sup> hHPC with JS1 or shPol47-encoding LV prior to xenograft transplantation in BRG newborn mice. At 1-week post-hHPC transplantation, the site of hHPC injection and major hematopoietic cell niche at this age, i.e. the liver of the BRG-HIS mice, was analyzed for the presence of human hematopoietic GFP<sup>+</sup> cells. We did not observe any difference in the absolute number of human cells nor in the *in vivo/in vitro* ratio of human GFP<sup>+</sup> cells between JS1 control and shPol47-expressing BRG-HIS mice (Figure 5a,b). At 4 weeks post-hHPC transplantation, the bone marrow and the thymus of BRG-HIS mice are the major sites of human hematopoietic cell accumulation. No difference in the absolute number of human cells nor in the *in vivo/in vitro* ratio of human GFP<sup>+</sup> cells was noted between the two groups of mice in the bone marrow at this age (Figure 5a,b). By contrast, the seeding of the thymus by shPol47-transduced (GFP<sup>+</sup>) human progenitors was almost abolished whereas a GFP<sup>+</sup> ratio around 1.0 was observed in the thymus of control animals (Figure 5b). A similar number of human CD45<sup>+</sup> thymocytes was retrieved from the two BRG-HIS mouse groups, suggesting that seeding of the thymus by human progenitors

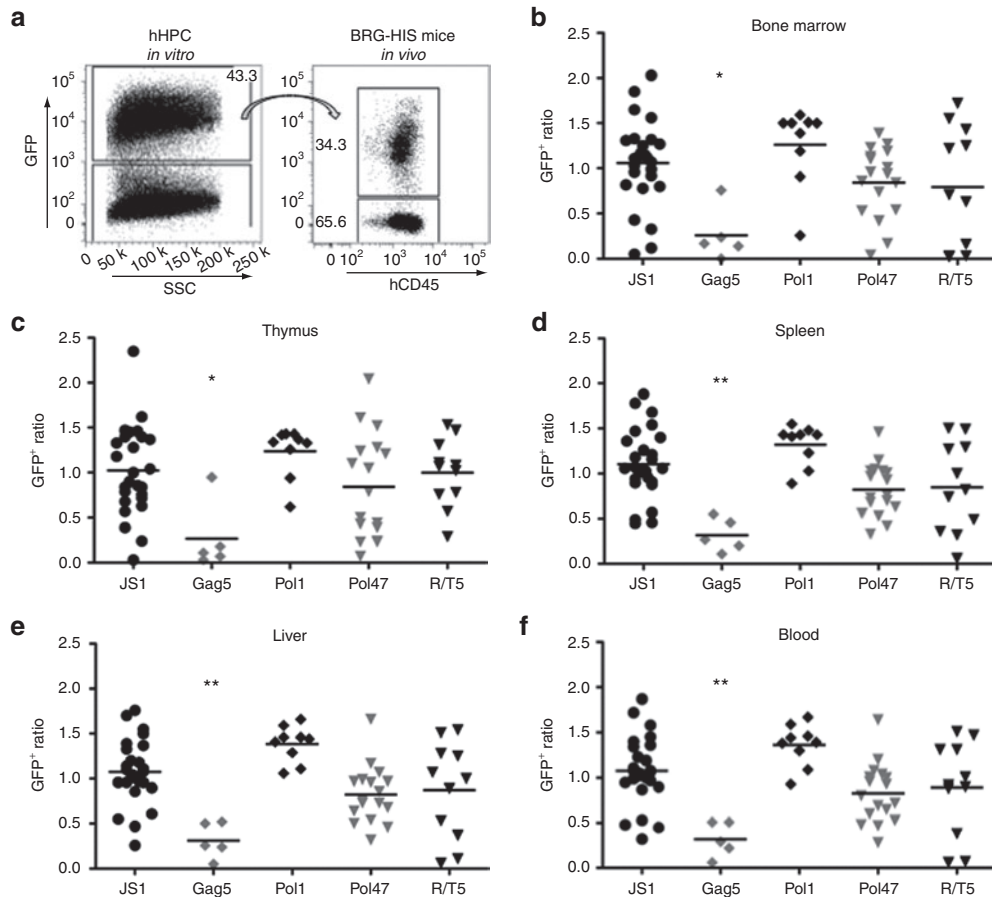

**Figure 3 Recovery of LV-transduced human hematopoietic cells in the lymphoid organs of BRG-HIS mice.** BRG-HIS mice generated with LV-transduced hHPC for the expression of shGag5 (grey diamonds,  $n = 5$ ), shPol1 (black diamonds,  $n = 9$ ), shPol47 (grey triangle,  $n = 17$ ) or shR/T5 (black triangle,  $n = 11$ ) were analyzed 10–13 weeks post-hHPC transplantation and compared with control animals (empty JS1-transduced hHPC; black circles,  $n = 26$ ). (a) The flow cytometry dot plots show the transduction efficiency *in vitro* of hHPC transduced with LV (left panel, SSC side scatter) and the frequency of GFP expression among human hCD45<sup>+</sup> hematopoietic cells *in vivo* in the BRG-HIS mice (right panel). (b–f) The results are expressed as the GFP<sup>+</sup> ratio between the frequency of human GFP<sup>+</sup> cells measured in the animals (*in vivo*) and the frequency of GFP<sup>+</sup> hHPC injected in the newborn mice (*in vitro* transduction efficiency). The GFP<sup>+</sup> ratio is shown for the bone marrow (b), thymus (c), spleen (d), liver (e), and blood (f). The results (mean) are pooled from two to eight independent experiments, and each dot represents an individual animal. \* $P < 0.05$ ; \*\* $P < 0.01$  (Kruskal–Wallis test).

is exclusively impaired for the shPol47-expressing GFP<sup>+</sup> cell subpopulation. In the case of shPol47, the delay in thymus seeding by human shRNA-expressing progenitors was overcome at weeks 10–13 post-hHPC transplantation, with similar human cell number and GFP recovery in the thymus and all the analyzed organs of JS1 and shPol47-treated animals (Table 1 and Figure 3).

#### Simultaneous expression of three nontoxic shRNAs is safe *in vitro* and *in vivo*

As for HAART, combination of multiple shRNAs into a single LV resulted in additive inhibition of HIV-1 *in vitro*.<sup>26</sup> Even more importantly, the combinatorial RNAi approach prevented the selection of RNAi-escape variants.<sup>26</sup> We combined three shRNAs (shPol1, shPol47, and shR/T5; R3) or four shRNAs candidates (shGag5, shPol1, shPol47, and shR/T5; R4) into the JS1 LV (Figure 6a) and evaluated the *in vitro* safety of these combinatorial LV in the hFCF assay (Figure 2a). The numbers of CFU-GM, BFU-E, and CFU-GEMM were comparable between R3 LV and JS1 control LV (Figure 6b). The hHPC

transduced with the shGag5-encoding R4 LV gave rise to a reduced number of CFU-GM as compared with control hHPC.

We next assessed the *in vivo* safety of a combinatorial shRNA treatment in BRG-HIS mice. As for the single shRNA treatment experiments, similar numbers of human cells were detected in all the analyzed organs of BRG-HIS mice transplanted with shRNA-transduced hHPC as compared with the control JS1 group (Supplementary Table S1, online). When the *in vivo* frequency of human GFP<sup>+</sup> cells in the blood and lymphoid organs of the animals was measured and compared with the original *in vitro* transduction efficiency, we observed a severely reduced recovery of human GFP<sup>+</sup> cells *in vivo* in the R4 animals (Figure 6c–g). This recovery was even lower than observed for the single shGag5 experimental group (Figure 3). The recovery of GFP<sup>+</sup> cells from R3-treated BRG-HIS mice was lower than in the JS1 control BRG-HIS mice, although it was significantly lower only for the spleen and blood. This reduced global recovery in the spleen was explained in the analysis of different human immune cell subsets, where we measured a reduced frequency of

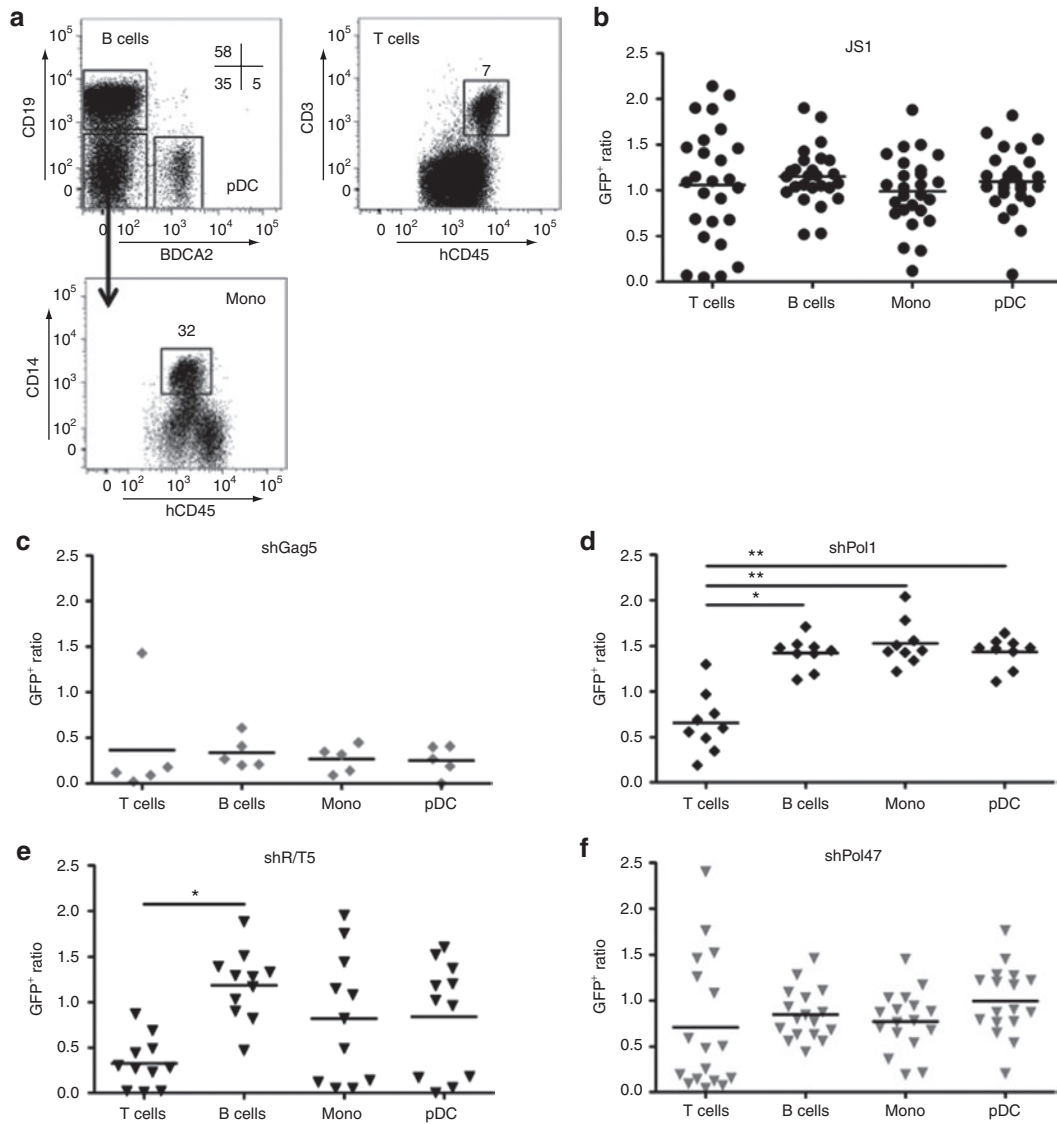

**Figure 4 Differential shRNA expression in human cell subsets of BRG-HIS mice.** GFP expression by several human immune cells was measured in the spleen of BRG-HIS mice. (a) The analyzed subsets were human T cells (CD3<sup>+</sup>), B cells (BDCA2<sup>-</sup>CD19<sup>+</sup>), plasmacytoid dendritic cells (pDC; CD19<sup>-</sup>BDCA2<sup>+</sup>), and monocytes (Mono; CD19<sup>-</sup>BDCA2<sup>-</sup>CD14<sup>+</sup>). (b–g) GFP expression by these subsets was measured in BRG-HIS mice reconstituted with the following LV: control JS1 (b), shGag5 (c), shPol1 (d), shR/T5 (e), or shPol47 (f). The results are expressed as the GFP<sup>+</sup> ratio between the frequency of human GFP<sup>+</sup> cells measured in the spleen of the animals (*in vivo*) and the frequency of GFP<sup>+</sup> hHPC injected in the newborn mice (*in vitro* transduction efficiency). The results (mean) are pooled from two to eight independent experiments, and each dot represents an individual animal. \**P* < 0.05; \*\**P* < 0.01 (Friedman test).

GFP<sup>+</sup> cells in the human B- and T-cell subsets (Figure 6h). Still, R3-transduced hHPC gave rise to multilineage *in vivo* reconstitution of the human immune system, demonstrating the *in vivo* safety of the R3 construct. When compared with the shGag5 group, the R3-treated BRG-HIS mice exhibited higher recovery of GFP<sup>+</sup> cells in the primary lymphoid organs (bone marrow, thymus) and the liver, suggesting that the reconstitution kinetics by the R3-transduced cells might be delayed, as observed with shPol47.

#### Inhibition of HIV-1 replication on *in vivo* generated human CD4<sup>+</sup> T cells expressing three shRNA against HIV-1

To evaluate the capacity of human shRNA<sup>+</sup> cells to inhibit HIV-1 replication, we isolated mature human CD4<sup>+</sup> T cells

from NSG-HIS mice produced either with control JS1 or with R3-transduced hHPC. At sacrifice, splenocytes were harvested and GFP<sup>+</sup> human CD4<sup>+</sup> T cells were isolated by fluorescence-activated cell sorting. The sorted CD4<sup>+</sup> T cells were challenged *ex vivo* by either a wild-type HIV-1 strain (LAI) or a shPol1-resistant HIV-1 virus (HIV-1 LAI-D30N) that was selected during mono-RNAi therapy.<sup>28</sup> HIV-1 LAI replication was inhibited in transduced GFP<sup>+</sup> CD4<sup>+</sup> T cells from R3-expressing NSG-HIS mice but not in the control GFP<sup>+</sup> CD4<sup>+</sup> T cells from JS1-expressing NSG-HIS mice (Figure 7a). When the sorted cells were challenged with the shPol1-resistant HIV-1 virus, viral inhibition was still observed for the transduced GFP<sup>+</sup> CD4<sup>+</sup> T cells from R3-expressing NSG-HIS mice but not in the control GFP<sup>+</sup> CD4<sup>+</sup> T cells from

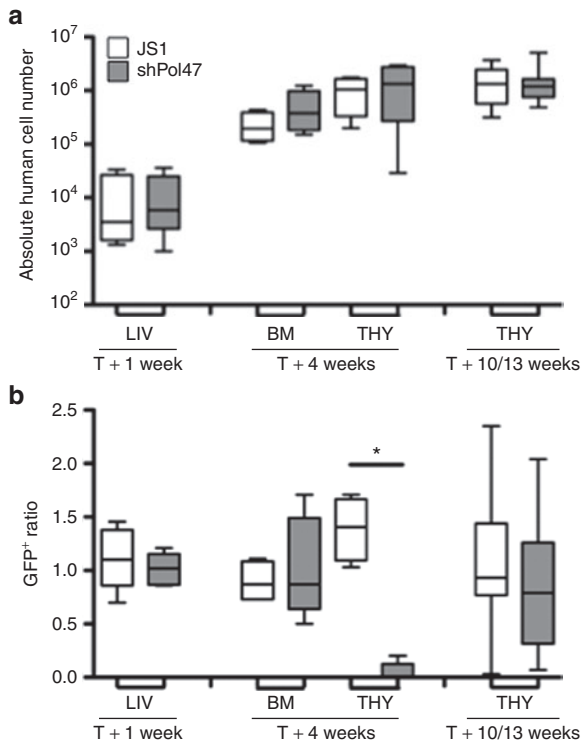

**Figure 5 Impaired seeding of BRG-HIS mouse thymus by shPol47-expressing human progenitor cells.** CD34<sup>+</sup>CD38<sup>-</sup>hHPC were transduced with JS1-control or shPol47-expressing LV and injected into newborn BRG mice. At 1 and 4 weeks post-hHPC transplantation, JS1 (white boxes;  $n = 4$ ) and shPol47 (grey boxes;  $n = 5$ ) BRG-HIS mice were analyzed in the major sites of hematopoiesis for the absolute number of human CD45<sup>+</sup> cells (**a**) and for GFP<sup>+</sup> ratio in human hematopoietic cells (**b**). The GFP<sup>+</sup> ratio is the ratio between the frequency of human GFP<sup>+</sup> cells measured in the animals (*in vivo*) and the frequency of GFP<sup>+</sup> hHPC injected in the newborn mice (*in vitro* transduction efficiency). The results are pooled from four independent experiments, and each dot represents an individual animal. \* $P < 0.05$  (Mann–Whitney test). BM, bone marrow; LIV, liver; THY, thymus.

JS1-expressing NSG-HIS mice (Figure 7b). Taken together, these results demonstrate that *in vivo* generated human CD4<sup>+</sup> T cells that express R3 are resistant to HIV-1 replication. Furthermore, as for HAART, pre-existing resistance to one of the inhibitors (shPol1) is not sufficient to confer escape from inhibition by the other two shRNAs (shPol47 and shR/T5).

## Discussion

We have previously reported the proof-of-concept of testing the *in vivo* impact of expressing a shRNA directed against the HIV-1 *nef* gene in CD34<sup>+</sup>CD38<sup>-</sup> hHPC in BRG-HIS mice.<sup>11</sup> The development of human hematopoiesis-derived cells was not affected in the shNef-hHPC engrafted mice and the shNef-transduced CD4<sup>+</sup> T cells that develop in the animals are resistant to HIV-1 challenge *ex vivo*. This shNef targets a nonconserved region of the HIV-1 genome and a nonessential gene for HIV-1 replication. Consequently, this shRNA was not attractive for further development of an anti-HIV RNAi-based gene therapy. Here, we selected four anti-HIV-1 shRNA

candidates that target essential HIV-1 genes and highly conserved regions of the HIV-1 genome among all HIV-1 subtypes (>73% target conservation of the shRNA target sequence in all virus isolates present in the Los Alamos database), in particular subtype B isolates (>80%).<sup>30</sup> We evaluated the preclinical safety profile *in vivo* in view of further development of this RNAi-based gene therapy towards clinical trial phase I.

Evaluation of the safety of shRNA expression by hHPC was initially performed using the classical human colony-forming cell assay. No apparent toxicity was scored in this assay for single shRNA expression. In contrast, when safety of shRNA expression by human hematopoietic cells was assessed *in vivo* in mice humanized for the immune system, a single shRNA (shGag5) exhibited a negative impact on the development of human hematopoietic cells. Only the shGag5<sup>+</sup>-expressing cells were affected, as development of nontransduced cells occurred normally in these animals to reach absolute number of human cells similar to control humanized mice. These results demonstrate that mice humanized for the human immune system constitute a valuable and sensitive *in vivo* preclinical model to evaluate the hematopoietic safety of gene therapy strategies, for several reasons. First, the hHPCs that are engrafted in the immunodeficient newborn mice are similar to the ones that would be genetically engineered for *ex vivo* gene therapy of HIV-infected patients. Second, as the hHPCs transplanted in the mice consist of a mixture of transduced (GFP<sup>+</sup>) and nontransduced hHPC (GFP<sup>-</sup>), the human immune system in the animals is thus constituted of shRNA-expressing cells (GFP<sup>+</sup>) and nontransduced cells (GFP<sup>-</sup>). Besides evaluating the control mice vs. the shRNA-treated mice, this approach provides a perfect internal control to test for adverse effects of shRNA expression on hematopoiesis by simply following the frequency of GFP<sup>+</sup> cells over time, as compared with the original hHPC inoculum. This approach turned out to be more sensitive than a simple screen of the total human cell population. We previously used such a strategy to develop a sensitive cell culture system to detect transgene toxicity.<sup>31</sup> Finally, HIS mice allow for the long-term evaluation of associated toxicity, which could for instance not be observed in the relatively short-term colony-forming cell assay with shGag5.

We demonstrate in HIS mice that shPol1, shPol47, and shR/T5 were safe, as they did not affect the *in vivo* development of the human immune system, both in terms of absolute human cell numbers and shRNA-expressing cell recovery. When combined into a single LV, simultaneous expression of these three shRNAs did not affect the *in vivo* generation of a multilineage human immune system, even though GFP recovery is less effective for R3 than the vectors that express a single shRNA from this combination. Still, GFP recovery with the R3 vector was better than with shGag5 alone, and similar or close to the JS1 control in the primary organs. Moreover, we provide proof-of-concept for the capacity of human shRNA<sup>+</sup> CD4<sup>+</sup> T cells harvested from R3-treated HIS mice to resist HIV-1 infection. As for HAART, combinatorial shRNA treatment exhibits additive HIV-1 inhibition and prevents the selection of escape virus variants. In fact, we demonstrated that R3-expressing cells remain nonsusceptible for an HIV-1 variant with an escape mutation in a single shRNA target sequence. These data should be extended in the future by long-term HIV infection

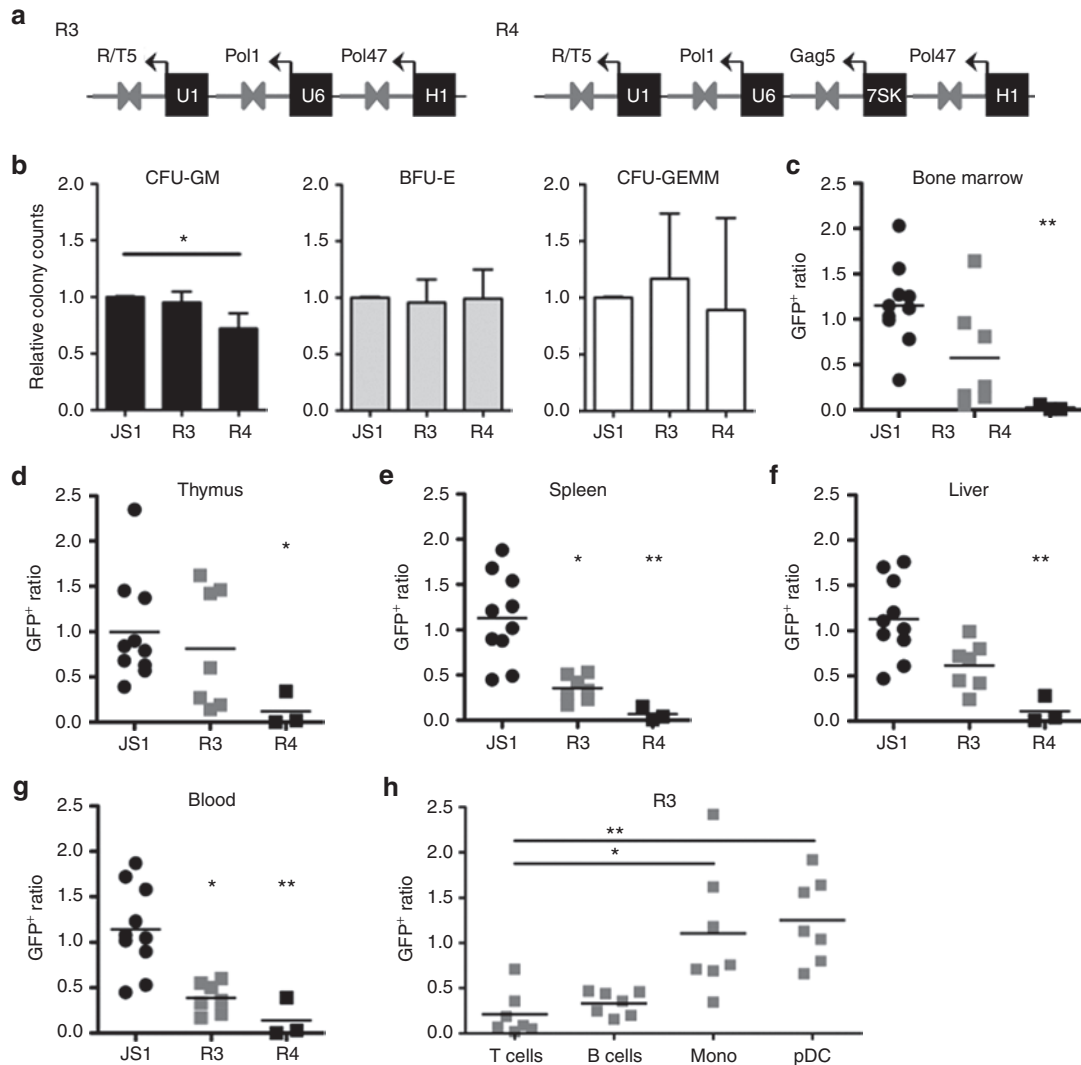

**Figure 6** *In vitro* and *in vivo* safety of combinatorial shRNA treatment. (a) Schematic representation of the R3 and R4 LV. The R3 vector expresses the three validated shRNAs (shR/T5, shPol1, and shPol47) and the R4 vector also contains shGag5. (b) Human fetal liver CD34<sup>+</sup>CD38<sup>-</sup> hHPC were transduced with JS1, R3 or R4-expressing LV and analyzed as in Figure 2b. (c–g) JS1 (black circles, n = 10), R3 (grey squares, n = 7), R4 (black squares, n = 3) groups of BRG-HIS mice were analyzed 10–13 weeks after transplantation. The GFP<sup>+</sup> ratio in human hematopoietic cells was determined in the bone marrow (c), thymus (d), spleen (e), liver (f), and blood (g). The GFP<sup>+</sup> ratio is the ratio between the frequency of human GFP<sup>+</sup> cells measured in the animals (*in vivo*) and the frequency of GFP<sup>+</sup> hHPC injected in the newborn mice (*in vitro* transduction efficiency). (h) GFP expression by human immune cell subsets was measured in the spleen of BRG-HIS mice generated with R3-expressing hHPC. The results are pooled from two independent experiments, and each dot represents an individual animal. \*P < 0.05; \*\*P < 0.01 (Kruskal–Wallis test for group comparison and Friedman test for cell subset comparison).

experiments in the HIS mouse to analyze the potential emergence of HIV escape mutants over time.

Analysis of the early events of tissue colonization and cell differentiation taking place in the BRG-HIS mice engrafted with shRNA-hHPC revealed that seeding of the thymus by human bone marrow GFP<sup>+</sup> progenitors was delayed, with kinetics varying depending on the respective shRNA. This observation could reflect several nonmutually exclusive mechanisms affecting e.g., generation of thymus seeding progenitor cells,<sup>32–34</sup> migration of thymus seeding progenitor cells in the circulation, their entry into the thymus or the earliest steps of T-cell lineage commitment. Consequently, such a delayed capacity of shRNA-transduced cells to initiate thymopoiesis and to accumulate in secondary lymphoid organs

may cause a reduced frequency of human GFP<sup>+</sup> T cells in the periphery of adult HIS mice.

One explanation for this phenomenon could be off-target effects. The shGag5 may target unrelated mRNAs that are involved in hematopoiesis. Transcriptional interference of the shRNA-cassette with GFP transcription from the PGK polymerase II promoter seems unlikely as all single shRNA constructs were driven from the same H1 polymerase III promoter, yet exhibited a different outcome with only shGag5 showing toxic effects. Similarly, as all tested shRNA constructs were designed in the same JS1 backbone, reduced LV integration can be ruled out. Alternatively, a more general mechanism such as saturation of the miRNA pathway can be considered.<sup>11,35–39</sup> The miRNA pathway is involved in hematopoiesis



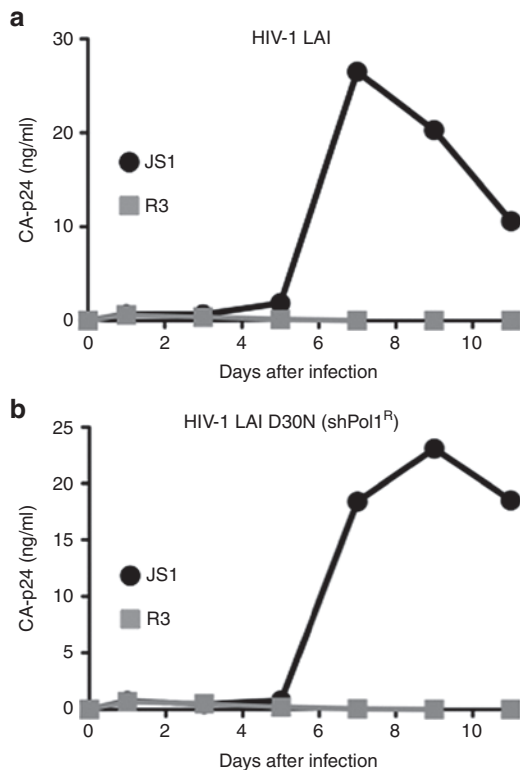

**Figure 7 R3<sup>+</sup> human CD4<sup>+</sup> T cells from NSG-HIS mice inhibit HIV-1 replication *ex vivo*.** Transduced (GFP<sup>+</sup>) human CD4<sup>+</sup> T cells from spleen of JS1 and R3-treated NSG-HIS mice were sorted and infected either with HIV-1 LAI (a) or a HIV-1 LAI strain resistant to shPol1 (HIV-1 LAI D30N) (b). Virus spread was monitored by measuring CA-p24 production with ELISA. The HIV-1 inhibition experiment was repeated three-times and one representative experiment is shown.

and differentiation of hHPC into lineage-committed progenitors and the migration of hematopoietic cells from the bone marrow to the thymus and the periphery.<sup>40,41</sup> One can imagine that any disturbance in this network might result in impaired hematopoietic development. To explain the shGag5-specific effects, one could propose that it is ineffectively processed, thus occluding the RNAi machinery by saturation of one of the critical proteins. Saturation of the miRNA pathway may also occur if the shRNA is expressed at too high levels due to, for example, multiple integrations of the LV in the target cells. In the clinical setting one would therefore aim for a low number of integrations per cells, preferably only a single copy, as we tried to mimic in the HIS mouse experiments.

A reduction of the number of modified human T cells seems to be a common feature of diverse treatments in the humanized HIS mouse model, including an inducible LV,<sup>42</sup> a LV expressing a human/rhesus macaque TRIM5 $\alpha$  isoform, a CCR5 shRNA and a TAR decoy,<sup>43</sup> or a LV expressing two shRNAs.<sup>44</sup> Notably, a reduced frequency of shRNA-expressing T cells was also observed in another humanized mouse setting, using hHPC transduced with a LV encoding three anti-HIV genes (shRNA against Tat/Rev, CCR5-ribozyme, and TAR-decoy) and subsequently injected in human thymic grafts of the SCID-hu mice.<sup>14</sup> Six weeks after hHPC injection in the mice, the frequency of GFP<sup>+</sup> cells was particularly

reduced for the shRNA-expressing vector in human thymocytes. This combinatorial therapy was tested in a pilot clinical trial in four patients with AIDS-related non-Hodgkin's lymphoma where autologous CD34<sup>+</sup> hHPC were transduced with a LV encoding the three anti-HIV small RNA and infused back into the patients.<sup>45</sup> This gene therapy was well tolerated with no signs of toxicity and shRNA expression was detected in PBMCs. Interestingly, the relative number of transduced cells increased in two patients after a spike of HIV-1 viremia, suggesting selective expansion of the protected cells.<sup>46</sup>

What would be the significance of the temporary reduction of human shRNA-expressing T cells for a clinical application? Based on the latter clinical study and our data showing potent virus inhibition with the shRNA combination, it is likely that the developmental disadvantage of shRNA-expressing cells will be counterbalanced by the survival advantage upon HIV-1 infection. Even with maintenance of a high plasma viral load, such a selective survival advantage of treated human CD4<sup>+</sup> T cells has already been observed in HIS mice treated with either a triple-combination anti-HIV LV or a dual shRNA LV and subsequently infected by HIV-1 (both R5- and X4-tropic strains).<sup>43,44</sup> In this scenario, HIV-1 resistant shRNA-expressing cells are likely to be positively selected, as the unprotected cells will be removed by the immune system upon HIV-1 infection, leading to a clinical benefit for the patient. Still, this hypothesis remains to be formally proven, and alternative therapeutic strategies can also be envisioned, e.g., using clinical-grade cell sorting of modified cells – as already performed in HIS mice<sup>47</sup> – or *in vivo* delivery of T cell-targeted shRNA.<sup>13</sup> It should be emphasized that human T-cell homeostasis is particularly sub-optimal in BRG-HIS mice.<sup>15,18,19</sup> Thus it remains unclear whether a similar delayed seeding of the thymus and peripheral lymphoid organs will be seen in a human clinical setting. Overall, the R3 LV that encodes the shPol1, shPol47, and shR/T5 shRNAs – respectively targeting the HIV-1 open-reading frames for integrase, protease and Tat/Rev – might represent an attractive prototype for further clinical development, which requires further evaluation, especially concerning the potential delay in reconstitution by R3-expressing T cells.

## Materials and methods

**Constructs, LV preparation, virus titer determination and cell culture.** LV – JS1, R/T5, Gag5, Pol1, Pol47, R3, and R4 – were previously described.<sup>10,11</sup> The JS1 LV carries the GFP reporter gene that allows for distinction between transduced (GFP<sup>+</sup>) cells and nontransduced (GFP<sup>-</sup>) cells. LV<sup>48</sup> were produced by cotransfection of vector constructs and packaging constructs pSYNGP, pRSV-rev, and pVSVg in 293T cells with lipofectamine-2000 (Invitrogen, Carlsbad, CA, USA), as previously described.<sup>49</sup> The virus stocks were concentrated on a 5% sucrose layer by ultracentrifugation (32 K, 90 minutes) and aliquots of 350  $\mu$ l were stored at  $-80$  °C. Virus production was determined by CA-p24 ELISA and virus titers were determined by serial dilution of virus and transduction on SupT1 cells. Human embryonic kidney 293T cells were grown at 37 °C and 5% CO<sub>2</sub> in DMEM (Gibco BRL) and SupT1 cells were grown in RPMI 1640 (Gibco BRL). Both media were supplemented with 10% fetal calf serum, minimal essential medium nonessential amino acids, penicillin (100 U/ml) and streptomycin (100  $\mu$ g/ml).

**Isolation of human hematopoietic progenitor cells and transduction procedure.** Human hematopoietic progenitor cells (hHPC) were isolated from human fetal liver tissue samples obtained from elective abortions, with gestational age of 14–18 weeks. The use of fetal liver tissues was approved by the Medical Ethical Committee of the Academic Medical Center of the University of Amsterdam and was contingent on informed consent. Single-cell fetal liver suspensions were prepared and hHPC were isolated as previously described.<sup>29</sup> In brief, CD34<sup>+</sup> cells were enriched by immunomagnetic sorting (indirect CD34 human progenitor cell isolation kit, Miltenyi Biotec) and the CD34<sup>+</sup>CD38<sup>-</sup>CD3<sup>-</sup>CD19<sup>-</sup>CD56<sup>-</sup>BDCA2<sup>-</sup> (further referred to as CD34<sup>+</sup>CD38<sup>-</sup>) hHPC were sorted using a FACSAria (BD Biosciences, Franklin Lakes, NJ) to purity  $\geq 99\%$ .

The sorted CD34<sup>+</sup>CD38<sup>-</sup> hHPC were transduced with the different LVs after overnight culture in IMDM (Invitrogen, Carlsbad CA, USA) supplemented with Yssel's medium, 5% normal human serum (NHS), 20 ng/ml human stem cell factor (huSCF; PeproTech, Rocky Hill, NJ, USA), 20 ng/ml human thrombopoietin (huTPO; PeproTech), 20 ng/ml human interleukin-3 (huIL-3, PeproTech) and 20 ng/ml human interleukin-7 (huIL-7; Cytheris). The following day, the cells were incubated for 6–8 hours with virus supernatant in fibronectin-coated plates (30  $\mu$ g/ml; Takara Biomedicals, Otsu, Shiga, Japan).

**Colony-forming cell assay.** CD34<sup>+</sup>CD38<sup>-</sup> hHPC were transduced by the different LVs. GFP<sup>+</sup> transduced CD34<sup>+</sup>CD38<sup>-</sup> hHPC were sorted with live fluorescence-activated cell sorting and plated in duplicate in 12-well tissue culture plates at concentrations of 100 cells per well in methylcellulose medium (MethoCult H4435, StemCell Technologies, Vancouver, BC, Canada). Cultures were incubated for 12–14 days at 37 °C in a 5% CO<sub>2</sub>-humidified atmosphere. BFU-E and colony-forming units-granulocyte/macrophage and CFU-granulocyte/erythrocyte/macrophage/megakaryocyte (CFU-GM and CFU-GEMM, respectively) were scored by microscopy according to manufacturer's instructions. CFC assay was repeated four-times with duplicates for each conditions tested per experiment.

**Generation of BRG-HIS and NSG-HIS mice.** BALB/c (H-2<sup>d</sup>) Rag2<sup>-/-</sup>IL2R $\gamma_c$ <sup>-/-</sup> (BRG) mice<sup>50</sup> and NOD.scid.IL2R $\gamma_c$ <sup>-/-</sup> (NSG) mice<sup>51</sup> were bred and maintained in individual ventilated cages, and were fed autoclaved food and water. Mice with a human immune system (BRG-HIS and NSG-HIS) were generated as previously described.<sup>29</sup> Briefly, newborn (<1-week old) BRG and NSG mice received sub-lethal (3.5 Gy BRG/1Gy NSG) total body irradiation with a X-ray Röntgen source or <sup>137</sup>Cs, and were injected intrahepatic (i.h.) with  $5 \times 10^4$ – $10 \times 10^4$  transduced CD34<sup>+</sup>CD38<sup>-</sup> hHPC. NSG mice actually express a SIRP $\alpha$  allele capable of properly interacting with the human CD47 protein.<sup>52</sup> CD47/SIRP $\alpha$  interaction is a major determinant of self and escape from phagocyte-mediated clearance,<sup>53</sup> especially in a xenograft setting.<sup>47</sup> Consequently, higher level of human cells can be found in NSG-HIS mice allowing isolation of more human CD4<sup>+</sup> T cells for HIV infection *ex vivo*. All manipulations of BRG-HIS and NSG-HIS mice were performed under laminar flow. Cell suspensions of the BRG-HIS and NSG-HIS mouse organs were prepared in RPMI1640 medium supplemented with 2% fetal calf serum.

**Flow cytometry analysis for cell surface markers.** Cell suspensions were labeled with anti-human mAb targeting the following cell surface markers: CD3 (SK7), CD4 (SK3), CD8 (SK1), CD19 (SJ25C1), CD45 (2D1), HLA-DR (G46-6), CD14 (M5E2), CD11c (S-HCL-3) from BD biosciences, CD1a (T6-RD1) from Coulter-Immunotech and BDCA2 (AC144) from Miltenyi Biotec (Bergisch Gladbach, Germany). Washings and reagent dilutions were done with PBS containing 2% fetal calf serum and 0.02% sodium azide (NaN<sub>3</sub>). All acquisitions were performed with a LSR-II (BD Bioscience) flow cytometer interfaced to FACS-Diva software system, and were analyzed with FlowJo software (Ashland, OR). Cellular debris and dead cells were excluded by their light-scattering characteristics and based on incorporation of 4',6-diamidino-2-phenylindole (DAPI, Sigma).

**HIV challenge *ex vivo*.** Human CD4<sup>+</sup> T cells from spleens of JS1 and JS1-R3-treated NSG-HIS mice were sorted ( $\geq 99\%$  pure) using an ARIA sorter (BD Bioscience) according to the CD45<sup>+</sup>CD3<sup>+</sup>CD4<sup>+</sup>CD8<sup>-</sup> phenotype and the presence or absence of GFP expression. Cells from NSG-HIS mice were subsequently stimulated for 2 days with PHA (4 mg/ml) in RPMI culture medium supplemented with IL-2 (100 U/ml) and 10% fetal calf serum. The human CD4<sup>+</sup> T cells sorted from the NSG-HIS mice ( $5 \times 10^4$  in 0.2 ml) were infected with HIV-1 LAI or HIV-1 LAI-D30N virus supernatant (0.2 ng CA-p24) and virus spread was monitored by measuring CA-p24 production by ELISA. The HIV-1 inhibition experiment was repeated three-times.

**Statistical analyses.** Data were subjected to a Mann–Whitney test for two-group comparisons, a Kruskal–Wallis test followed by a Dunns post-test for multiple group comparisons, and a Friedman test followed by a Dunns post-test for multiple matched group comparisons as indicated in the figure legends. The obtained *P* values were considered significant \**P* < 0.05, \*\**P* < 0.01, \*\*\**P* < 0.001.

## Supplementary material

**Table S1.** Absolute number of human CD45<sup>+</sup> cells in the organs of shRNA-treated BRG-HIS mice.

**Acknowledgments.** Mireille Centlivre was supported by Marie Curie Intra-European fellowship (MEIF-CT-2007–039689). Nicolas Legrand, Kees Weijer and Hergen Spits were supported by the Bill and Melinda Gates Foundation (Grand Challenges in Global Health program – GC4 'Human Vaccine Consortium'). This research was sponsored by NWO-CW (Chemical Sciences), ZonMw (Medical Sciences), and the Dutch AIDS Fund (project 2006006). We thank the staff of the ABSL-2 unit of the Animal Research Institute Amsterdam (ARIA) of the AMC-UvA for excellent care of the animals. We also thank Berend Hooibrink for expertise in cell sorting and maintenance of the flow cytometry facility, Stephan Heynen for assistance with the CA-p24 ELISA, and the technical staff of the laboratory for Cell Therapy of Sanquin for counting colonies. Lastly, we are grateful to the Bloemenhove Clinic (Heemstede, The Netherlands) for providing fetal tissues. Nicolas Legrand is currently an employee of AXENIS, a contract research organization generating humanized mouse models, although this was not the case during the execution

and completion of this study. The other authors declare no competing financial interests.

- Yuki, SA, Shergill, AK, McQuaid, K, Gianella, S, Lampiris, H, Hare, CB et al. (2010). Effect of raltegravir-containing intensification on HIV burden and T-cell activation in multiple gut sites of HIV-positive adults on suppressive antiretroviral therapy. *AIDS* **24**: 2451–2460.
- Llibre, JM, Buzón, MJ, Massanella, M, Esteve, A, Dahl, V, Puertas, MC et al. (2012). Treatment intensification with raltegravir in subjects with sustained HIV-1 viraemia suppression: a randomized 48-week study. *Antivir Ther (Lond)* **17**: 355–364.
- Siliciano, JD, Kajdas, J, Finzi, D, Quinn, TC, Chadwick, K, Margolick, JB et al. (2003). Long-term follow-up studies confirm the stability of the latent reservoir for HIV-1 in resting CD4+ T cells. *Nat Med* **9**: 727–728.
- Hütter, G, Nowak, D, Mossner, M, Ganepola, S, Müssig, A, Allers, K et al. (2009). Long-term control of HIV by CCR5 Delta32/Delta32 stem-cell transplantation. *N Engl J Med* **360**: 692–698.
- Allers, K, Hütter, G, Hofmann, J, Loddenkemper, C, Rieger, K, Thiel, E et al. (2011). Evidence for the cure of HIV infection by CCR5 $\Delta$ 32/32 stem cell transplantation. *Blood* **117**: 2791–2799.
- Berkhout, B (2009). Toward a durable anti-HIV gene therapy based on RNA interference. *Ann N Y Acad Sci* **1175**: 3–14.
- Berkhout, B and ter Brake, O (2009). Towards a durable RNAi gene therapy for HIV-AIDS. *Expert Opin Biol Ther* **9**: 161–170.
- Burnett, JC, Zaia, JA and Rossi, JJ (2012). Creating genetic resistance to HIV. *Curr Opin Immunol* **24**: 625–632.
- Fire, A, Xu, S, Montgomery, MK, Kostas, SA, Driver, SE and Mello, CC (1998). Potent and specific genetic interference by double-stranded RNA in *Caenorhabditis elegans*. *Nature* **391**: 806–811.
- ter Brake, O, Konstantinova, P, Ceylan, M and Berkhout, B (2006). Silencing of HIV-1 with RNA interference: a multiple shRNA approach. *Mol Ther* **14**: 883–892.
- ter Brake, O, Legrand, N, von Eije, KJ, Centlivre, M, Spits, H, Weijer, K et al. (2009). Evaluation of safety and efficacy of RNAi against HIV-1 in the human immune system (Rag-2(-)/gammac(-/-)) mouse model. *Gene Ther* **16**: 148–153.
- Wang, GP, Levine, BL, Binder, GK, Berry, CC, Malani, N, McGarrity, G et al. (2009). Analysis of lentiviral vector integration in HIV+ study subjects receiving autologous infusions of gene modified CD4+ T cells. *Mol Ther* **17**: 844–850.
- Kumar, P, Ban, HS, Kim, SS, Wu, H, Pearson, T, Greiner, DL et al. (2008). T cell-specific siRNA delivery suppresses HIV-1 infection in humanized mice. *Cell* **134**: 577–586.
- Anderson, J, Li, MJ, Palmer, B, Remling, L, Li, S, Yam, P et al. (2007). Safety and efficacy of a lentiviral vector containing three anti-HIV genes—CCR5 ribozyme, tat-rev siRNA, and TAR decoy—in SCID-hu mouse-derived T cells. *Mol Ther* **15**: 1182–1188.
- Legrand, N, Cupedo, T, van Lent, AU, Ebeli, MJ, Weijer, K, Hanke, T et al. (2006). Transient accumulation of human mature thymocytes and regulatory T cells with CD28 superagonist in “human immune system” Rag2(-)/gammac(-/-) mice. *Blood* **108**: 238–245.
- Manz, MG (2007). Human-hemato-lymphoid-system mice: opportunities and challenges. *Immununity* **26**: 537–541.
- Shultz, LD, Ishikawa, F and Greiner, DL (2007). Humanized mice in translational biomedical research. *Nat Rev Immunol* **7**: 118–130.
- Gimeno, R, Weijer, K, Voordouw, A, Uittenbogaart, CH, Legrand, N, Alves, NL et al. (2004). Monitoring the effect of gene silencing by RNA interference in human CD34+ cells injected into newborn RAG2(-) gammac(-/-) mice: functional inactivation of p53 in developing T cells. *Blood* **104**: 3886–3893.
- Traggiai, E, Chicha, L, Mazzucchelli, L, Bronz, L, Piffaretti, JC, Lanzavecchia, A et al. (2004). Development of a human adaptive immune system in cord blood cell-transplanted mice. *Science* **304**: 104–107.
- Ishikawa, F, Yasukawa, M, Lyons, B, Yoshida, S, Miyamoto, T, Yoshimoto, G et al. (2005). Development of functional human blood and immune systems in NOD/SCID/IL2 receptor {gamma} chain(null) mice. *Blood* **106**: 1565–1573.
- Denton, PW and Garcia, JV (2011). Humanized mouse models of HIV infection. *AIDS Rev* **13**: 135–148.
- Berges, BK and Rowan, MR (2011). The utility of the new generation of humanized mice to study HIV-1 infection: transmission, prevention, pathogenesis, and treatment. *Retrovirology* **8**: 65.
- Sato, K and Koyanagi, Y (2011). The mouse is out of the bag: insights and perspectives on HIV-1-infected humanized mouse models. *Exp Biol Med (Maywood)* **236**: 977–985.
- Van Duyn, R, Cardenas, J, Easley, R, Wu, W, Kehn-Hall, K, Klase, Z et al. (2008). Effect of transcription peptide inhibitors on HIV-1 replication. *Virology* **376**: 308–322.
- Denton, PW, Estes, JD, Sun, Z, Othieno, FA, Wei, BL, Wege, AK et al. (2008). Antiretroviral pre-exposure prophylaxis prevents vaginal transmission of HIV-1 in humanized BLT mice. *PLoS Med* **5**: e16.
- ter Brake, O, 't Hoof, K, Liu, YP, Centlivre, M, von Eije, KJ and Berkhout, B (2008). Lentiviral vector design for multiple shRNA expression and durable HIV-1 inhibition. *Mol Ther* **16**: 557–564.
- von Eije, KJ, ter Brake, O and Berkhout, B (2009). Stringent testing identifies highly potent and escape-proof anti-HIV short hairpin RNAs. *J Gene Med* **11**: 459–467.
- von Eije, KJ, ter Brake, O and Berkhout, B (2008). Human immunodeficiency virus type 1 escape is restricted when conserved genome sequences are targeted by RNA interference. *J Virol* **82**: 2895–2903.
- van Lent, AU, Centlivre, M, Nagasawa, M, Karrich, JJ, Pouw, SM, Weijer, K et al. (2010). *In vivo* modulation of gene expression by lentiviral transduction in “human immune system” Rag2(-) gamma c (-/-) mice. *Methods Mol Biol* **595**: 87–115.
- Knoepfel, S, Centlivre, M, Liu, YP, Boutimah, F and Berkhout, B (2012). Selection of RNAi-based inhibitors for anti-HIV gene therapy. *World J Virol* **1**: 79–90.
- Eekels, JJ, Pasternak, AO, Schut, AM, Geerts, D, Jeeninga, RE and Berkhout, B (2012). A competitive cell growth assay for the detection of subtle effects of gene transduction on cell proliferation. *Gene Ther* **19**: 1058–1064.
- O'Neill, HC (1991). Prothymocyte seeding in the thymus. *Immunol Lett* **27**: 1–6; discussion 7.
- Tan, JB, Visan, I, Yuan, JS and Guidos, CJ (2005). Requirement for Notch1 signals at sequential early stages of intrathymic T cell development. *Nat Immunol* **6**: 671–679.
- Haddad, R, Guimiot, F, Six, E, Jourquin, F, Setterblad, N, Kahn, E et al. (2006). Dynamics of thymus-colonizing cells during human development. *Immunity* **24**: 217–230.
- Boudreau, RL, Monteys, AM and Davidson, BL (2008). Minimizing variables among hairpin-based RNAi vectors reveals the potency of shRNAs. *RNA* **14**: 1834–1844.
- McBride, JL, Boudreau, RL, Harper, SQ, Staber, PD, Monteys, AM, Marlins, I et al. (2008). Artificial miRNAs mitigate shRNA-mediated toxicity in the brain: implications for the therapeutic development of RNAi. *Proc Natl Acad Sci USA* **105**: 5868–5873.
- Castanotto, D, Sakurai, K, Lingeman, R, Li, H, Shively, L, Aagaard, L et al. (2007). Combinatorial delivery of small interfering RNAs reduces RNAi efficacy by selective incorporation into RISC. *Nucleic Acids Res* **35**: 5154–5164.
- Grimm, D, Streetz, KL, Jopling, CL, Storm, TA, Pandey, K, Davis, CR et al. (2006). Fatality in mice due to oversaturation of cellular microRNA/short hairpin RNA pathways. *Nature* **441**: 537–541.
- Vickers, TA, Lima, WF, Nichols, JG and Crooke, ST (2007). Reduced levels of Ago2 expression result in increased siRNA competition in mammalian cells. *Nucleic Acids Res* **35**: 6598–6610.
- Kanellopoulou, C, Muljo, SA, Kung, AL, Ganesan, S, Drapkin, R, Jenuwein, T et al. (2005). Dicer-deficient mouse embryonic stem cells are defective in differentiation and centromeric silencing. *Genes Dev* **19**: 489–501.
- Xiao, C and Rajewsky, K (2009). MicroRNA control in the immune system: basic principles. *Cell* **136**: 26–36.
- Centlivre, M, Zhou, X, Pouw, SM, Weijer, K, Kleibeuker, W, Das, AT et al. (2010). Autoregulatory lentiviral vectors allow multiple cycles of doxycycline-inducible gene expression in human hematopoietic cells in vivo. *Gene Ther* **17**: 14–25.
- Walker, JE, Chen, RX, McGee, J, Nacey, C, Pollard, RB, Abedi, M et al. (2012). Generation of an HIV-1-resistant immune system with CD34(+) hematopoietic stem cells transduced with a triple-combination anti-HIV lentiviral vector. *J Virol* **86**: 5719–5729.
- Ringpis, GE, Shimizu, S, Arokium, H, Camba-Colón, J, Carroll, MV, Cortado, R et al. (2012). Engineering HIV-1-resistant T-cells from short-hairpin RNA-expressing hematopoietic stem/progenitor cells in humanized BLT mice. *PLoS ONE* **7**: e33492.
- DiGiusto, DL, Krishnan, A, Li, L, Li, H, Li, S, Rao, A et al. (2010). RNA-based gene therapy for HIV with lentiviral vector-modified CD34(+) cells in patients undergoing transplantation for AIDS-related lymphoma. *Sci Transl Med* **2**: 36ra43.
- Burnett, JC, Rossi, JJ and Tiemann, K (2011). Current progress of siRNA/shRNA therapeutics in clinical trials. *Biotechnol J* **6**: 1130–1146.
- Legrand, N, Huntington, ND, Nagasawa, M, Bakker, AQ, Schotte, R, Strick-Marchand, H et al. (2011). Functional CD47/signal regulatory protein alpha (SIRP(alpha)) interaction is required for optimal human T- and natural killer- (NK) cell homeostasis in vivo. *Proc Natl Acad Sci USA* **108**: 13224–13229.
- Dull, T, Zufferey, R, Kelly, M, Mandel, RJ, Nguyen, M, Trono, D et al. (1998). A third-generation lentivirus vector with a conditional packaging system. *J Virol* **72**: 8463–8471.
- Seppen, J, Rijnberg, M, Cooreman, MP and Oude Elferink, RP (2002). Lentiviral vectors for efficient transduction of isolated primary quiescent hepatocytes. *J Hepatol* **36**: 459–465.
- Weijer, K, Uittenbogaart, CH, Voordouw, A, Couwenberg, F, Seppen, J, Blom, B et al. (2002). Intrathymic and extrathymic development of human plasmacytoid dendritic cell precursors in vivo. *Blood* **99**: 2752–2759.
- Shultz, LD, Lyons, BL, Burzenski, LM, Gott, B, Chen, X, Chaleff, S et al. (2005). Human lymphoid and myeloid cell development in NOD/LtSz-scid IL2R gamma null mice engrafted with mobilized human hematopoietic stem cells. *J Immunol* **174**: 6477–6489.
- Takenaka, K, Praslava, TK, Wang, JC, Mortin-Toth, SM, Khalouei, S, Gan, OI et al. (2007). Polymorphism in Sirpa modulates engraftment of human hematopoietic stem cells. *Nat Immunol* **8**: 1313–1323.
- Oldenborg, PA, Zheleznyak, A, Fang, YF, Lagenaur, CF, Gresham, HD and Lindberg, FP (2000). Role of CD47 as a marker of self on red blood cells. *Science* **288**: 2051–2054.



**Molecular Therapy—Nucleic Acids** is an open-access journal published by Nature Publishing Group. This work is licensed under a Creative Commons Attribution-NonCommercial-NoDerivative Works 3.0 License. To view a copy of this license, visit <http://creativecommons.org/licenses/by-nc-nd/3.0/>

Supplementary Information accompanies this paper on the Molecular Therapy—Nucleic Acids website (<http://www.nature.com/mtna>)