



**HAL**  
open science

## Detecting the macroevolutionary signal of species interactions

Luke J Harmon, Cecilia S Andreazzi, Florence Débarre, Jonathan Drury, Emma E Goldberg, Ayana B Martins, Carlos J Melián, Anita Narwani, Scott L Nuismer, Matthew W Pennell, et al.

► **To cite this version:**

Luke J Harmon, Cecilia S Andreazzi, Florence Débarre, Jonathan Drury, Emma E Goldberg, et al.. Detecting the macroevolutionary signal of species interactions. *Journal of Evolutionary Biology*, 2019, 32 (8), pp.769-782. 10.1111/jeb.13477 . hal-03002995

**HAL Id: hal-03002995**

**<https://hal.sorbonne-universite.fr/hal-03002995>**

Submitted on 13 Nov 2020

**HAL** is a multi-disciplinary open access archive for the deposit and dissemination of scientific research documents, whether they are published or not. The documents may come from teaching and research institutions in France or abroad, or from public or private research centers.



L'archive ouverte pluridisciplinaire **HAL**, est destinée au dépôt et à la diffusion de documents scientifiques de niveau recherche, publiés ou non, émanant des établissements d'enseignement et de recherche français ou étrangers, des laboratoires publics ou privés.



Distributed under a Creative Commons Attribution 4.0 International License

**REVIEW**

# Detecting the macroevolutionary signal of species interactions

Luke J. Harmon<sup>1,2</sup>  | Cecilia S. Andreazzi<sup>3</sup> | Florence Débarre<sup>4</sup>  | Jonathan Drury<sup>5</sup> |  
 Emma E. Goldberg<sup>6</sup> | Ayana B. Martins<sup>1,7</sup> | Carlos J. Melián<sup>1</sup> | Anita Narwani<sup>8</sup> |  
 Scott L. Nuismer<sup>2</sup> | Matthew W. Pennell<sup>9</sup> | Seth M. Rudman<sup>10</sup> | Ole Seehausen<sup>1,11</sup> |  
 Daniele Silvestro<sup>12</sup>  | Marjorie Weber<sup>13</sup> | Blake Matthews<sup>1,14</sup>

<sup>1</sup>Department of Fish Ecology and Evolution, Center for Ecology, Evolution and Biogeochemistry, Eawag, Kastanienbaum, Switzerland

<sup>2</sup>Department of Biological Sciences, University of Idaho, Moscow, Idaho

<sup>3</sup>Fiocruz Mata Atlântica, Fundação Oswaldo Cruz, Rio de Janeiro, Brazil

<sup>4</sup>Sorbonne Université, UPMC Univ Paris 06, CNRS, IRD, INRA, Université Paris Diderot, Institute of Ecology and Environmental Sciences (UMR7618), Paris, France

<sup>5</sup>Department of Biosciences, Durham University, Durham, UK

<sup>6</sup>Department of Ecology, Evolution and Behavior, University of Minnesota, Saint Paul, Minnesota

<sup>7</sup>Instituto de Física 'Gleb Wataghin', Universidade Estadual de Campinas, Campinas, Brazil

<sup>8</sup>Department of Aquatic Ecology, Swiss Federal Institute of Aquatic Science and Technology, Eawag, Dübendorf, Switzerland

<sup>9</sup>Department of Zoology and Biodiversity Research Centre, University of British Columbia, Vancouver, British Columbia

<sup>10</sup>Department of Biology, University of Pennsylvania, Philadelphia, Pennsylvania

<sup>11</sup>Institute of Ecology and Evolution, University of Bern, Bern, Switzerland

<sup>12</sup>Department of Biological and Environmental Sciences, Global Gothenburg Biodiversity Centre, University of Gothenburg, Gothenburg, Sweden

<sup>13</sup>Department of Plant Biology & Program in Ecology, Evolution, and Behavior, Michigan State University, East Lansing, Michigan

<sup>14</sup>Aquatic Ecology and Evolution, Institute of Ecology and Evolution, University of Bern, Bern, Switzerland

**Correspondence**

Luke J. Harmon, Department of Biological Sciences, University of Idaho, 875 Perimeter Dr, MS 3051, Moscow, ID 83844.  
 Email: lukeh@uidaho.edu

**Funding information**

Schweizerischer Nationalfonds zur Förderung der Wissenschaftlichen Forschung, Grant/Award Number: 31003A\_153464, 31003A\_163338 and Z32Z0\_166422; Agence Nationale de la Recherche, Grant/Award Number: ANR-14-ACHN-0003-01; Knut och Alice Wallenbergs Stiftelse; Swedish Research Council, Grant/Award Number: 2015-04748; Division of Environmental Biology, Grant/Award Number: 1208912 and 1450653

**Abstract**

Species interactions lie at the heart of many theories of macroevolution, from adaptive radiation to the Red Queen. Although some theories describe the imprint that interactions will have over long timescales, we are still missing a comprehensive understanding of the effects of interactions on macroevolution. Current research shows strong evidence for the impact of interactions on macroevolutionary patterns of trait evolution and diversification, yet many macroevolutionary studies have only a tenuous relationship to ecological studies of interactions over shorter timescales. We review current research in this area, highlighting approaches that explicitly model species interactions and connect them to broad-scale macroevolutionary patterns. We also suggest that progress has been made by taking an integrative interdisciplinary look at individual clades. We focus on African cichlids as a case study of how this approach can be fruitful. Overall, although the evidence for species interactions shaping macroevolution is strong, further work using integrative and model-based approaches is needed to spur progress towards understanding the complex dynamics that structure communities over time and space.

**KEYWORDS**

coevolution, extinction, macroevolution, network, phylogeny, speciation, species interactions, trait evolution

## 1 | INTRODUCTION

Species interactions are pervasive in natural ecosystems. Species parasitize (Goater, Goater, & Esch, 2013) and eat one another (Pimm, 1982), cooperate (Stachowicz, 2001) and compete (Tilman, 1982), exploit one another for reproduction (Bronstein, Alarcón, & Geber, 2006), and alter both the physical (Jones, Lawton, & Shachak, 1997) and the selective environments (Futuyma, 2017; Matthews et al., 2014; Odling-Smee, Erwin, Palkovacs, Feldman, & Laland, 2013) of other species. Our scientific understanding of species interactions underlies diverse fields of biology, and it continues to improve through models (Abrams & Cortez, 2015; Allhoff & Drossel, 2013; Week & Nuismer, 2019), observations (Meiners, Griswold, Harris, & Ernest, 2017; Ponisio, Gaiarsa, & Kremen, 2017) and experiments (Kloesener, Bose, & Schulte, 2017; Livne-Luzon et al., 2017). For the purposes of this review, we define species interactions broadly: ecological associations between two or more different species in a common environment. This definition encompasses a wide range of phenomena that occur across dramatically different levels in the biological hierarchy, from individuals to populations, species and clades. Our discussions centre mainly on interactions that occur at the level of individual organisms. We also ignore hybridization, a type of species interaction with dramatically different consequences outside the scope of the current paper.

Many prominent theories of macroevolution (evolution at or above the species level) share a focus on species interactions as a primary factor (Simpson, 1945; Stanley, 1979). The ecological theory of adaptive radiation describes how clades respond to ecological opportunity driven by a lack of competitive interactions with other species (Schluter, 2000a). The escape-and-radiate model, described in more detail below, supposes that diversification rates depend on trophic interactions (Ehrlich & Raven, 1964). The Red Queen theory states that species constantly evolve in response to interacting species (Quental & Marshall, 2013; Van Valen, 1973). Under theories of clade replacement, the extinction of one clade is coupled with the growth of another (Gilinsky & Bambach, 1987; Sepkoski, 1981; Silvestro, Antonelli, Salamin, & Quental, 2015). In coevolutionary arms races, interacting species engage in constant adaptation to gain an advantage over one another (Becerra, Noge, & Venable, 2009; Berenbaum & Feeny, 1981; Vermeij, 1994). In the biotic interactions hypothesis, species interactions provide the impetus for novelty (Dobzhansky, 1950). Finally, the geographic mosaic theory postulates an ever-changing landscape of interactions that shape macroevolution (Thompson, 2005).

Despite the prevalence of hypotheses linking species interactions and macroevolution, testing predictions across such disparate scales is challenging. Studies of species interactions over short timescales may not necessarily provide strong tests of macroevolutionary theories. This disconnect occurs because many macroevolutionary theories are verbal and imprecise about short-term mechanisms. At the same time, it remains unclear how existing knowledge of short-term species interactions might enable predictions at deeper timescales. Even though we know that species interact, there are

several reasons why these interactions may, in principle, leave little or no detectable imprint on long-term patterns in macroevolutionary data, such as fossils or phylogenetic trees (Hubbell, 2006; Rosindell, Hubbell, He, Harmon, & Etienne, 2012). For example, some interactions are weak or rapidly fluctuate over time or space (Emmerson & Yearsley, 2004; Turcotte, Corrin, & Johnson, 2012; Wootton & Emmerson, 2005). Summed over many generations and locations, such interactions might not leave a consistent signature (Eldredge et al., 2005; Hansen & Houle, 2004). However, alternate theories implicate these same properties of species interactions in shaping macroevolution. For example, rapidly fluctuating interactions might exaggerate the pace of macroevolution in the tropics compared to regions with weaker interactions (Schemske, Mittelbach, Cornell, Sobel, & Roy, 2009). Likewise, the geographic mosaic theory states that diffuse and rapidly fluctuating community interactions shape the evolution of diversity over long timescales (Thompson, 2005). This contrast illustrates that we still lack a cohesive grasp of the macroevolutionary impacts of species interactions (Jablonski, 2008).

Despite the inherent challenges of linking species interactions with macroevolution, incorporating species interactions into studies over deep time could greatly improve our understanding of the factors that shape the evolution of biodiversity. Here, we discuss our current understanding of the effects of species interactions on macroevolutionary patterns (Figure 1). Looking to the future, we specifically highlight integrative approaches that pair comparative analyses with other types of observational and/or experimental data to form a more complete picture of the macroevolution of focal clades (Seehausen, 2015a; Weber & Agrawal, 2012). We also emphasize clearly defined model-based phylogenetic comparative methods (Pennell & Harmon, 2013), which test evolutionary hypotheses using phylogenetic trees in conjunction with phenotypic data on individuals and populations. Typically, such methods require a previously estimated phylogenetic tree along with information about the extant (and in some cases extinct) species in that tree. These methods are particularly promising because accurate phylogenetic trees are increasingly available across the tree of life (Hinchliff et al., 2015) and can add a historical perspective to existing data on extant species' traits and genomes. Together, this work can lead us towards a better understanding of the macroevolutionary impacts of species interactions.

## 2 | EVIDENCE FOR THE EFFECT OF SPECIES INTERACTIONS ON MACROEVOLUTION

There is a rich history of investigating the macroevolutionary effects of species interactions. Taken as a whole, this work clearly demonstrates that species interactions affect patterns of trait evolution, as well as speciation and extinction rates (Weber, Wagner, Best, Harmon, & Matthews, 2017), and finally that species interaction networks evolve through time (Peralta, 2016). Recent methodological advances, especially using phylogenetic trees, have inspired new studies in this area.

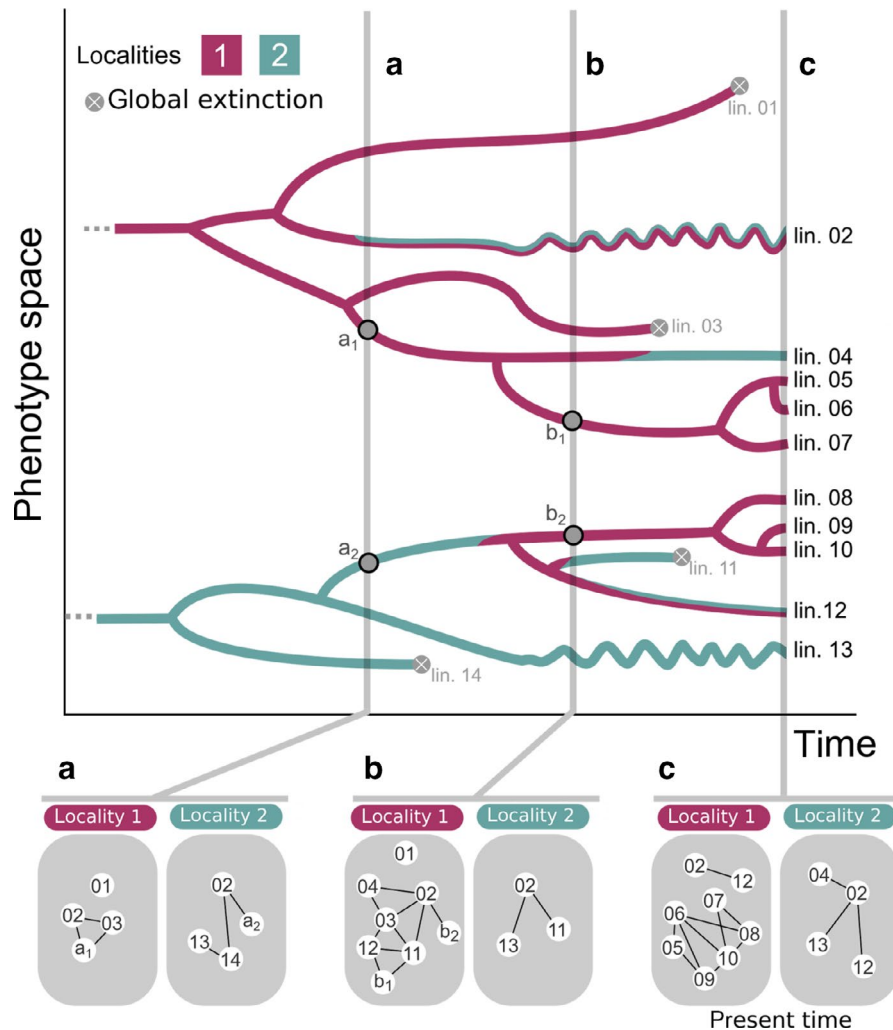

**FIGURE 1** Phylogenetic trees can record historical patterns of speciation, trait evolution and distribution. Top panel: phylogenetic tree of two interacting clades showing trait evolution (vertical axis), lineage divergence (bifurcations) and lineage extinction (crosses). lin. = lineages; a<sub>1</sub>, a<sub>2</sub>, b<sub>1</sub> and b<sub>2</sub> highlight ancestral states of selected branches. Bottom panels: a, b and c show snapshots of the species interaction network and community assembly through time. Species interactions evolve in time and are regulated by both co-occurrence and phenotype, such that co-occurring lineages that are closer in phenotypic space interact most strongly. Trait evolution and coevolution may result in different patterns in the phylogenetic tree such as convergence, divergence, branching and extinction

## 2.1 | Species interactions shape trait evolution

Many fundamental questions about macroevolution have traditionally been formulated in terms of how specific interactions affect the evolution of species' traits. Hypotheses linking interaction types (competition, mutualism, etc.) with trait macroevolution are myriad. For example, theory on ecological opportunity postulates that the rate of evolution of species' traits is determined by the strength and number of competitive interactions they experience, so that species with few competitors evolve more rapidly than species that compete with many similar species (Freckleton & Harvey, 2006; Mahler, Luke Mahler, Revell, Glor, & Losos, 2010; Schluter, 2000a). Strong competition is also hypothesized to drive persistent directional and stabilizing selection in certain systems, with macroevolutionary implications such as shifting optima across clades and long-term stasis.

Beyond competition, other types of interactions are also expected to influence trait evolution in multiple ways (Thompson, 2005). For example, mutualisms are hypothesized to lead to the evolution of trait matching, in which high trait complementarity and convergence are supposed to maximize fitness and in turn decrease rates of evolution via stabilizing selection [e.g. trait matching in plant-insect mutualisms; (Bronstein et al., 2006)]. Alternatively, under an arms race scenario, the combined action of mutualistic interactions and competition for mutualistic partners could increase rates of evolution via diversifying selection [e.g. arms races in pollinator attraction; (Whittall & Hodges, 2007; Yoder & Nuismer, 2010)].

Fossil data, when available, can help gain a clear picture of species interactions and their effects on trait evolution (Liow et al., 2017). There is also clear evidence from phylogenetic comparative analyses that species interactions can influence

trait evolution. These studies generally use traits, trees or geographic patterns as proxies for particular interactions (Alcantara & Lohmann, 2010; Espinoza, Wiens, & Tracy, 2004; Mouquet et al., 2012; Rasmann, Sergio, & Agrawal, 2011; Turcotte, Davies, Thomsen, & Johnson, 2014). For example, one can use the coexistence of species pairs as a stand-in for interactions and test for patterns consistent with trait evolution via character displacement (Morales-Castilla, Matias, Gravel, & Araújo, 2015). Sister-species comparisons have repeatedly demonstrated that when closely related species co-occur, they often differ in functional traits (Bothwell, Montgomerie, Loughheed, & Martin, 2015; Davies, Meiri, Barraclough, & Gittleman, 2007; Davies et al., 2012; Losos, 1990), microhabitat usage (Freeman, 2015) and traits related to mating (Grossenbacher & Whittall, 2011). It is also possible that convergence might evolve during co-occurrence (Abrams, 1986, 1996) and support species coexistence (Fox & Vasseur, 2008), but empirical examples are lacking (Fox & Vasseur, 2008; Schluter, 2000b). Clade-wide competition, where competition occurs among many species in a clade, also leaves a detectable signature. For example, interactions affect the rates at which traits and ecological niches evolve in marine reef fishes (McGee et al., 2015), and coexistence predicts rates of divergence in floral scents among a clade of California wildflowers (Weber et al., 2018). Finally, many studies assume that closely related species share similar traits and interact most strongly, thus using the phylogeny itself as a proxy for potential species interactions (Morales-Castilla et al., 2015; Mouquet et al., 2012). This approach has been especially common in community phylogenetics (Webb, Ackerly, McPeck, & Donoghue, 2002), where phylogenetic distance occasionally explains coexistence patterns within and among communities. Such studies assume that measures of evolutionary relatedness can be used to predict trait similarity and therefore also interaction strength and community assembly (Burns & Strauss, 2011; Maherali & Klironomos, 2012; Tucker, Davies, Cadotte, & Pearse, 2018). Empirical counterexamples exist however (Best & Stachowicz, 2013; Godoy, Kraft, & Levine, 2014; Narwani, Alexandrou, Oakley, Carroll, & Cardinale, 2013), suggesting that the assumptions behind community phylogenetic approaches may often not hold (Germain, Williams, Schluter, & Angert, 2018; Mayfield & Levine, 2010; Narwani, Matthews, Fox, & Venail, 2015) see “*Limitations of using proxies for species interactions,*” below (Germain et al., 2018; Mayfield & Levine, 2010; Narwani et al., 2015).

## 2.2 | Species interactions affect lineage diversification

Species interactions have also been shown to impact lineage diversification (speciation and extinction) rates. This type of effect is central to many long-standing theories of macroevolution. For example, the “escape-and-radiate” model hypothesizes a link between the presence and intensity of plant-herbivore interactions and enhanced diversification rates, such that, for example, plants that escape their main herbivores experience elevated diversification rates

(Ehrlich & Raven, 1964). Macroevolutionary signatures of species interactions affecting diversification can occur in several possible ways. Diversification of one clade could be influenced by the evolution of a novel interaction trait, by traits or species richness of another clade (McPeck, 1996; Thompson, 1999; Yoder et al., 2010), or via coordinated speciation across two different clades (Page, 2003). Previous work in this area has generally relied on proxies for species interactions, testing for relationships between these proxies and speciation and/or extinction rates. For example, comparisons of sister clades that differ in traits associated with species interaction indicated that the evolution of these traits is associated with increased lineage diversification rates (Barraclough, Vogler, & Harvey, 1998; Farrell, Dussourd, & Mitter, 1991; Hodges, 1997; Mitter, Farrell, & Wiegmann, 1988). One can also more directly test for an association between a proxy trait and diversification using methods that specifically evaluate models where traits (or co-occurrence) are associated with speciation or extinction rates (FitzJohn, 2012; Goldberg, Lancaster, & Ree, 2011; Maddison, Midford, & Otto, 2007). For example, the evolution of plant extrafloral nectaries, which attract and maintain mutualistic defenders, is repeatedly associated with increased diversification rates in plants (Weber & Agrawal, 2014), and adaptation to nectarivory is associated with increased diversification rates in some parrots (Schweizer et al. 2014). These methods are most informative when the proxy trait has evolved many times, leading to “evolutionary replicates” that make a convincing case for a causal link between interactions and diversification (Maddison & FitzJohn, 2015).

One can also use co-occurrence as a proxy for interactions in studies of speciation and/or extinction. Work in this area has most commonly looked for diversity dependence, with the prediction that net diversification rates should slow as communities fill with species. For example, anole lizards on Greater Antillean islands show speciation rates that decline as species richness increases on each island (Rabosky & Glor, 2010). Alternatively, the order of arrival to a geographic region (Tanentzap et al., 2015) and the properties of competing lineages that arrive concurrently (Muschick et al., 2018; Wagner, Harmon, & Seehausen, 2014) might predict diversification rate. The fossil record, alone or in conjunction with phylogenetic trees, can also provide substantial insights into the diversity dynamics in evolving clades (Pires, Silvestro, & Quental, 2017; Quental & Marshall, 2010).

A separate body of work has focused on co-speciation, the process in which interactions among lineages lead to parallel phylogenies where speciation events in one clade are concordant with speciation events in the other clade (Thompson, 1994). Co-speciation has generally been hypothesized to occur in lineages that interact in particularly intimate ways, such as specialized mutualisms [e.g. figs and fig wasps (Cook & Rasplus, 2003; Jouselin & Van Noort, 2006; Jouselin et al., 2008), marine fishes and their bioluminescent bacteria (Dunlap et al., 2007), lichens (Piercey-Normore & Depriest, 2001)] or parasitic relationships [e.g. bats and mites (Bruyndonckx, Dubey, Ruedi, & Christe, 2009), gophers and lice (Hafner, Demastes, & Spradling, 2003); these and similar examples reviewed in de Vienne et al. (2013)

and Anderson (2015). Concordance of phylogenetic relationships and divergence times provides evidence for co-speciation in interacting clades (Page, 2003). However, although the hypothesis of interaction-driven co-speciation is intriguing, it is difficult to evaluate the link between species interactions and co-speciation patterns using phylogenetic approaches alone (de Vienne et al., 2013). This is because other processes, such as shared geography, dispersal colonization history or vicariance events, can lead to patterns of matching phylogenies without the need to invoke species interactions (Warren, Cardillo, Rosauer, & Bolnick, 2014). Additionally, host switching and similar phenomena can result in mismatched phylogenies even in otherwise tightly coevolved systems, obfuscating patterns. Indeed, a large number of studies have shown that phylogenetic trees of interacting lineages are almost never perfectly matched, but are typically more similar than expected by chance (de Vienne et al., 2013).

### 2.3 | Species interaction networks evolve through time

Finally, a newer body of work has focused on integrating species interaction networks—which summarize the pattern of interactions among a set of species—with phylogenetic trees to test hypotheses about the macroevolutionary signature of species interactions. Historical data on networks in the fossil record exist but are rare (Dunne, Williams, Martinez, Wood, & Erwin, 2008; Roopnarine, 2006), but phylogenetic trees might give insight into how interaction networks change over time (Morales-Castilla et al., 2015). However, the few studies that have been published thus far are mixed. On the one hand, data suggest that interaction networks tend to share common patterns of links across species (Pascual & Dunne, 2006). Given that interaction networks emerge and change throughout evolution, regularities in structure might indicate that species interaction networks change in predictable ways over macroevolutionary time-scales (Allhoff & Drossel, 2013; Bell, 2007; Loeuille & Loreau, 2005; Yoshida, 2003). There is also evidence that some networks harbour “phylogenetic signal,” where close relatives tend to interact with sets of species that are more similar than expected by chance (Bascompte & Jordano, 2007; Rezende, Jordano, & Bascompte, 2007a; Rezende, Lavabre, Guimarães, Jordano, & Bascompte, 2007b). On the other hand, other networks show little or no phylogenetic signal (Krasnov et al., 2012; Rohr & Bascompte, 2014). Together, network studies using phylogenies suggest that trait- and phylogeny-based approaches are sometimes poor predictors of coexistence patterns (Germain et al., 2018), yet large-scale phylogenetic patterns in networks remain suggestive of broader links between species interactions and macroevolution (Weber et al., 2017).

## 3 | CHALLENGES TO LINKING PATTERN TO PROCESS ACROSS SCALES

In general, there is strong evidence that interactions can impact evolution and that we can sometimes detect patterns on phylogenetic

trees that are consistent with species interactions. However, challenges remain. In particular, the specific mechanisms mediating interactions remain poorly understood, and linking macroevolutionary patterns to particular causal mechanisms is challenging.

### 3.1 | Limitations of using proxies for species interactions

As described above, common proxy-based approaches have limitations, and patterns in some large empirical datasets have proven to be far more complex than initially expected (Anacker & Strauss, 2014; Germain, Weir, & Gilbert, 2016; Morales-Castilla et al., 2015). There are good reasons for this. First of all, using phylogenetic trees as a proxy for species interactions can be problematic because trait similarity does not necessarily follow phylogenetic relatedness. Complex dynamics of traits and interactions across species can mean that phylogenetic trees themselves are a poor stand-in for interactions (Morales-Castilla et al., 2015). Co-occurrence, another common proxy for interactions, can be problematic because co-occurrence in the present day is not a good guide to long-term persistence (Mayfield & Levine, 2010), and geographic overlap on a map might be a poor indicator of the historical pattern of interactions among species (Losos & Glor, 2003). Even contemporary interactions may not be predicted by co-occurrence in cases of temporal or habitat segregation or micro-allopatry. In general, proxy-based approaches are limited by the quality of the proxy; that is, interpretations of the results will be contingent on how good of a surrogate the proxy is for the interaction of interest.

### 3.2 | Multiple processes generate similar patterns

A second outstanding issue is that any particular pattern might be consistent with more than one process-based explanation. For example, consider the hypothesis that species interactions drive diversification rates via ecological limits (Rabosky & Hurlbert, 2015). Under this hypothesis, we expect speciation rates to slow as communities become saturated with species, leading to a particular pattern of long branches towards the tips of a phylogenetic tree (Pybus & Harvey, 2000). This pattern is reasonably common in empirical phylogenetic trees (Rabosky & Hurlbert, 2015). However, there are other explanations that result in a very similar pattern and do not rely on species interactions (Etienne & Rosindell, 2012). For example, undersampled taxa or a protracted model of speciation, where speciation is modelled as a process that takes time to complete, can leave similar imprints on phylogenetic data (Etienne & Haegeman, 2012; Harmon & Harrison, 2015). This many-to-one relationship between pattern and process is common in macroevolutionary theories of species interactions, and it can complicate interpretation of any given analysis.

### 3.3 | Eco-evolutionary dynamics

Finally, although many approaches assume that ecological interactions drive both microevolutionary and macroevolutionary changes,

the reciprocal interplay between ecology and evolution complicates interpretations of causality. It is not always clear which process is the driving force and which the effect. For example, it can be difficult using current methods to untangle the causes from the effects of speciation, trait evolution and community assembly. Models where ecological and evolutionary processes interact over similar timescales might help resolve these issues (Govaert et al., 2018; Schoener, 2011).

## 4 | MODEL-BASED INTERACTION STUDIES CAN LINK DATA ACROSS SCALES

Overall, we suggest that work on species interactions and trait evolution across scales can be unified by fitting models that explicitly consider how species interactions are tied to trait variation and trait-dependent fitness variation, how those traits are related to variation in species' genomes, and how species interactions in turn affect trait evolution (Melián et al., 2018). We suggest that progress can be made by comparing the fit of these clearly delineated models with and without species interactions.

### 4.1 | Model-based approaches to understand trait evolution

We see great promise in applying mechanistic coevolutionary models from ecology using phylogenetic comparative data. As one primary example, Drury, Clavel, Manceau, and Morlon (2016) applied a coevolutionary model (Nuismer & Harmon, 2015) to comparative data to demonstrate that clade-wide competition can leave a detectable signature in phylogenies. In this model, competition depends on the phenotypic similarity of coexisting species, so patterns predicted by the model are different from both early-burst models and models where rates of evolution depend on the number of coexisting species (Manceau, Lambert, & Morlon, 2016). The next step is to evaluate whether such models will provide a good fit across additional data sets (Drury et al., 2016, 2018; Hutchinson, Gaiarsa, & Stouffer, 2018). However, this general approach provides a way to connect coevolutionary models and comparative data (Clarke, Thomas, & Freckleton, 2017; Manceau et al., 2016).

Beyond what has already been done, it will be promising to extend current model classes of trait evolution on phylogenetic trees to include interaction dynamics. To illustrate this approach, consider the question, Do species interactions leave a clear imprint on the evolution of traits? We can imagine a hypothetical model for the coevolution of hosts and their parasites that would include two coevolving clades, one for the parasites and one for their hosts. Each parasite species either has or lacks an antigen, and each host species either has or lacks a corresponding binding site. Parasites evolve to use hosts, so the rate at which parasite species gain the antigen increases with the frequency of the binding site in the host clade. Hosts evolve to be inhospitable to parasites, so the rate at which host species lose the binding site increases with the frequency of the

antigen in the parasite clade. Such a model would predict patterns of trait distributions among tips of a phylogenetic tree that would differ from those predicted under simple, noninteractive models of trait evolution, with changes in one trait strongly dependent on the frequency of another trait in the other clade.

Although the development of these types of models holds promise, the approach still needs to be implemented and the development of biological realism still poses challenges. A likelihood function for the model described above, needed to fit this model to comparative data, does not currently exist. The development of a likelihood function is feasible: recently, Manceau et al. (2016) outlined the type of approach that could lead to a solution. A second more substantial challenge to this work is incorporating shifting patterns of historical range overlap among species, since all members of clades typically have not coexisted at all times. Ideally, one would test whether this model, consistent with interactions shaping trait evolution, fits data better than a simple noninteractive Mk model fit to the two clades separately. Overcoming these challenges would lead to exciting and promising new realms of research.

### 4.2 | Model-based approaches to understand lineage diversification

Model-based studies of lineage diversification also exist, including models that consider interactions among lineages such as co-phylogenetic analyses (Page, 2003) and analysis of diversity-dependent speciation and extinction rates (Rabosky, 2013). Current approaches have provided strong suggestions that species interactions affect diversification rates. For example, density-dependent patterns support competition-driven diversification patterns (Rabosky & Glor, 2010); co-phylogenetic studies almost always show nonrandom concordance between hosts' and parasites' phylogenetic trees (Page, 2003); and at least in some cases, speciation and extinction rates are correlated across clades (Silvestro et al., 2015). However, the development of more mechanistic model-based approaches can broaden the scope of our tests while also helping to better connect the observed patterns to particular mechanisms. Such a synthetic approach may eventually help us better understand which mechanisms may dominate under what conditions.

As an example, we can describe model-based comparative methods that would incorporate the effects of traits in other clades on lineage diversification in a focal clade. Such models could ask, for instance, whether interactions across clades, such as competition, predation or parasitism, drive diversification. To do this, we would need to make a model where speciation and/or extinction rates depend on the traits of species in a different clade. There are already models where lineage traits affect their own speciation and/or extinction rates; these would need to be generalized so that it is traits of other lineages that matter. For example, the escape-and-radiate model can be approached via mathematical models of reciprocal feedback between both trait evolution and diversification. We can start with a coevolutionary model where insects have a feeding trait (or a set of such traits) and plants have a defence trait, both continuous. We

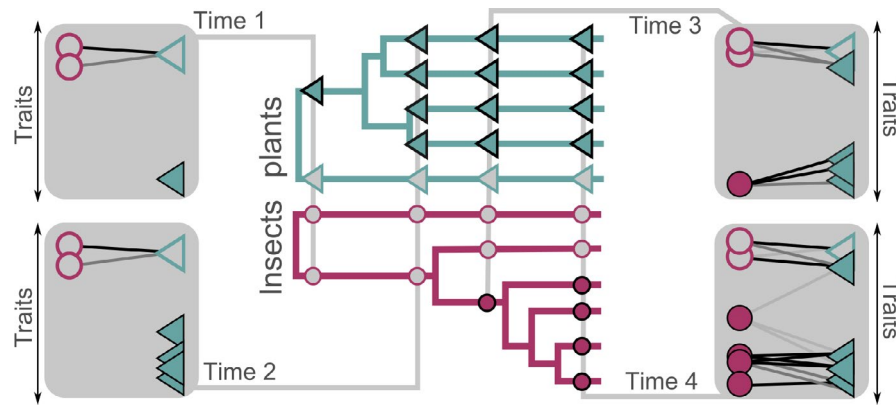

**FIGURE 2** A schematic depiction of the escape-and-radiate model described in the text. As the phylogenetic trees for insects and plants progress through time (left to right), diversification rates of both plants and insects vary depending on the relative interaction strength between lineages. The interaction between the two clades is determined by a feeding trait for insects and a defence trait for plants. Both sets of traits are projected in a trait space, where any insect that is close to a plant in trait space can feed well on that plant. Therefore, insects and plants represented with similar opacities have stronger links as shown by the darkness of the links. At time 1, one plant lineage (filled triangle) is far from all herbivores and experiences a burst of speciation at time 2. By contrast, at time 3, one insect (filled circle) is close to a set of underutilized plant species and diversifies in response at time 4

can modify a “matching” model, common in coevolutionary studies (Nuismer, 2017), which focuses on the difference between the feeding and defence traits (Nuismer & Harmon, 2015; Yoder & Nuismer, 2010). In our model, these traits can influence diversification rates (FitzJohn, 2012). For this example, insect diversification rates should increase when the traits match, whereas plant diversification rates should be highest when the traits are mismatched. The matching patterns can be assessed for either the closest pair of species or averaged clade-wide. We illustrate the behaviour of such a model in Figure 2. Using statistical model selection, one could assess the presence and strength of hypothesized cross-clade trait-dependent diversification. This brings our analyses closer to Ehrlich and Raven’s (1964) vision of escape-and-radiate coevolution. Such models might lead naturally to biologically realistic two-clade models of lineage co-diversification (Huelsenbeck, Rannala, & Larget, 2000), or models where speciation and/or extinction rates are coordinated across clades (Silvestro et al., 2015).

### 4.3 | Models for evolving interaction networks

Finally, model-based approaches are sorely needed to assess how species interaction networks evolve on trees, or how trees evolve in networks of interacting species. Work over the past several decades has established that species interaction networks have particular structural properties (Newman, 2010; Pascual & Dunne, 2006). We know much less, however, about how species interactions in networks evolve over macroevolutionary timescales (Poisot & Stouffer, 2016; see Figure 3). We also lack a framework to understand how novel interaction types emerge (Valiente-Banuet & Verdú, 2007). New comparative techniques that allow interaction type (e.g. competition, predation) and strength to coevolve over time may allow us to use phylogenetic comparative data to gather new insights into the origins of network structures.

For instance, a preliminary model of interactions evolving on trees might describe interactions between species X and species Y that come and go probabilistically with transition rates that are constant over time, and new species form that copy the links of their parents (Berg, Lässig, & Wagner, 2004; Krapivsky & Redner, 2005; Vázquez, Flammini, Maritan, & Vespignani, 2002), it is possible to predict the structure of interaction networks that emerges (Chung, Lu, Dewey, & Galas, 2003; Evlampiev & Isambert, 2008). An obvious weakness of this approach is that it does not allow the structure of the interaction network at any point in time to affect the probability of new interactions forming or existing interactions expiring. To capture more biological realism, this approach could be extended to allow the rate at which interactions form or dissolve to depend on the existing network structure of interactions. Such models could be used, for instance, to explore the intriguing hypothesis that species that attract mutualists initially become magnets for further mutualists, ultimately forming hubs within the interaction network (Bascompte & Jordano, 2013; Thompson, 2005). Rules could be included that increase the probability of interactions forming with species already well-endowed with mutualists. The challenge for the next generation of comparative approaches is to map this process of network evolution onto the phylogenetic tree(s) of the participating lineages.

With any of the above models in hand, it should, in principle, be possible to develop comparative approaches using model approximations and likelihood or, if that proves impossible, approximate Bayesian computation (Slater et al., 2012) or machine-learning approaches (Sukumaran, Economo, & Lacey Knowles, 2016) that rely on simulation. Overall, we believe that integrative mathematical approaches will be very helpful in understanding these complex dynamics that structure communities over time and space.



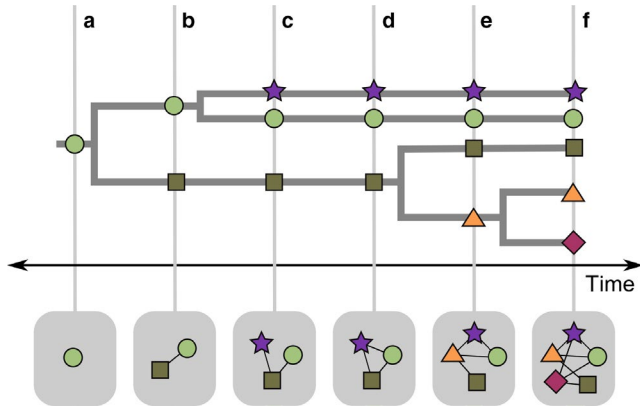

**FIGURE 3** A simple model for the evolution of interaction networks. We begin with a single species (a). We track the phylogenetic tree (top) and interaction network (bottom) of species generated by the model. After the first speciation event, the two daughter lineages interact with probability  $p$  (b). At the next speciation event, the daughter species inherit all of the interactions of the ancestral species (c). Interactions can also be gained (d) and lost (e) following speciation events and along the branches of the tree. After several speciation events and gains and losses of individual interactions, the model generates a phylogenetic tree and an interaction network (f). As long as the rates of interaction gain and loss along branches are not too great, then one obtains a network with “phylogenetic signal” so that close relatives tend to share interactions (Bienvenu, Débarre, & Lambert, 2018)

## 5 | AN INTERDISCIPLINARY TOOLKIT TO UNDERSTAND THE LONG-TERM EFFECTS OF SPECIES INTERACTIONS

In the sections above, we outlined promising new approaches to fit increasingly complex models involving species interactions to comparative data. However, there might be a limit to progress with this approach. Models involving interactions can, at the macroevolutionary scale, have many-to-one relationships with process-based models and require detailed information about parameters that can only come from short-term data. Unfortunately, so far, detailed quantitative connections between models and empirical systems are often still missing. More complex models also require that we estimate more model parameters, while estimating more model parameters precisely requires increasingly large sample sizes, which necessitates ever-larger phylogenetic trees including more species. The catch-22 here is that ever-larger trees tend to be older and to include increasingly disparate lineages, so that fitting a single model to the entire group can make less and less biological sense. Additionally, some processes are simply invisible or not distinguishable from one another if we choose to only look at phylogenetic trees and extant character data. In other words, there may be a limit to what one can learn about particular biological groups if one is limited to “standard” comparative analysis.

One solution to this limit is interdisciplinary approaches, which combine ecological, palaeontological, genomic, microevolutionary

and macroevolutionary data, often within a single focal clade, to ask fundamental questions about the effects of interactions on evolution. This type of approach has been used to great effect over the past decades in a few well-developed model systems. For example, in Darwin's finches, a combination of laboratory experiments, field studies, trait-based genomics and comparative analyses has led to a rich picture of how species have evolved and diversified in the Galápagos islands and how species interactions shaped this evolution (Campagna et al., 2017; Grant & Grant, 2011; Lamichhaney et al., 2015, 2018). Cichlid fishes are another particularly compelling example because the clade includes multiple replicate adaptive radiations, each featuring profound species interaction and functional trait diversity. One core feature of cichlid work is that researchers have focused on ways to bring microscale and macroscale data together in the same framework (see Box 1, Figure 4).

In these types of well-developed systems, researchers have brought together many different types of data and analyses in a comprehensive look at particular macroevolutionary questions. Unfortunately though, so far, detailed quantitative connections between models and well-studied empirical systems are still missing. Additionally, interdisciplinary work on other radiations—particularly large continental radiations—is sorely needed to complement the detailed work done in a few well-developed model systems. As a consequence, it is difficult to evaluate the general status of key “theories” of macroevolution, such as the ones described earlier in the article.

Pairing phylogenetic trees with experimental approaches that track how species interactions shape evolution over ecological timescales could provide another way to link microevolutionary and macroevolutionary processes. For example, evolve-and-resequence experiments, which directly track changes in allele frequencies in response to selection across replicate populations (Long, Liti, Luptak, & Tenailon, 2015; Turner, Stewart, Fields, Rice, & Tarone, 2011), present a potential way to identify genes that are strongly associated with species interactions, at least in species with a relatively short generation time. To date, many evolve-and-resequence experiments study the genetic basis of evolution owing to abiotic manipulations or anthropogenic selection (Dettman et al., 2012; Tobler et al., 2014; Turner et al., 2011). This methodology can also be used to find the genomic basis of adaptation in response to species interactions (Penczykowski, Laine, & Koskella, 2016). Experiments that manipulate the presence or interaction strength between a focal taxon and a species it interacts with, while maintaining control populations that do not have this interaction, yield a list of genes that show changes in allele frequencies in association with a given species interaction (Brockhurst & Koskella, 2013). One could then test whether these “species interaction genes” show signs of selection and/or altered evolutionary rates over macroevolutionary timescales. If loci associated with a species interaction have different evolutionary signals, it would provide evidence that species interactions alter evolution over macroevolutionary time

### Box 1 Interdisciplinary research sheds light on the adaptive radiation of cichlid fishes

Here, we present a conceptual model of what a unifying theory for diversification and evolution of ecological interactions might include (Figure 4). Our discussion is motivated by diverse and well-studied cichlid fish radiations (Salzburger, 2018; Seehausen, 2015b). We consider a hypothetical clade of species that have undergone an evolutionary radiation driven by species interactions.

We expect that due to density and frequency dependence, the adaptive landscape experienced by species changes dynamically as a consequence of trait evolution and lineage diversification and associated changes in the prevalence and distribution of resources (Seehausen, 2015b). Initial evolution is “classical” adaptive radiation in response to the distribution of resources accessible to the ancestral population (Moser et al., 2018). Once the first species enters a new combination of trait-by-resource space, it will experience renewed ecological opportunity and can radiate into a new guild (Yoder et al., 2010).

Most parts of our framework are supported by pieces of existing theory. For the regime on the left: (a) speciation theories such as by-product speciation theory (Rice & Hostert, 1993), adaptive speciation theory (Weissing, Edelaar, & van Doorn, 2011), theories of speciation by sexual selection and sexual conflict coupled with ecological character displacement (Ritchie, 2007); for the regime on the right: (b) community ecology theories such as niche theory (Chase & Leibold, 2003), competition theory (Tilman, 1982), assembly theory (Webb et al., 2002); (c) coevolution theory such as escape-and-radiate hypothesis (Ehrlich & Raven, 1964), co-speciation theory (Page, 2003), predator–prey and parasite–host coevolution theory (Nuismer, 2017), and the theory of mutualisms (Stachowicz, 2001).

New theory needs to be developed to predict when and where key events cause transitions between regimes. For example, at what point do trait evolution and lineage accumulation driven by competitive interactions generate new traits or trait values that allow a subclade to become a new trophic guild and eventually give rise to completely new interaction types (e.g. the evolution of a mutualist species from within a clade of competing species)? As a particular example, suppose a first intraclade predator (guild 4, Figure 4c) arises (Figure 4c, thick black arrow 1) that diversifies into specialists each of which is preying on just one or a few species of the phenotypically most divergent other clade (Figure 4c, clade 2). Suppose that the access of the new predator lineage to prey species from other clades gradually increases through further trait evolution. An escape-and-speciate co-diversification process could ensue. It should be possible to quantify the tree concordance between the clades that would be expected for such coevolution, that is alternating speciation in predator and prey clades (circled numbers 1, 2, 3, 4 in Figure 4c).

and that the genetic basis of these interactions is stable over long periods.

Implementing mechanistic models as part of an interdisciplinary toolkit will also identify areas where our models fall short of biological realism, generating ideas for future models and model extensions. For example, cichlids highlight the fact that we often ignore hybridization, one potentially important way that species interact that might be particularly important for adaptive radiation of these species, and might change the diversity and strength of ecological species interactions and the rate at which they emerge. New models, beyond the scope of this review, are almost surely needed in cases where network-like evolution cannot be described by a bifurcating tree. Even with this deficiency, new models are being developed that are more closely suited to investigating and quantifying the complexity of processes that matter for understanding evolution in the real world.

Ultimately, expanding our use of mechanistic models as tools embedded in a diverse, interdisciplinary toolkit will enrich our ability to be effective evolutionary detectives (Losos, 2007). We cannot travel back in time to collect data on distant macroevolutionary events (Muschick et al., 2018), but biologically informed and clearly defined models linking species interactions to macroevolutionary changes will aid us in our ability to rigorously evaluate whether macroevolutionary patterns are consistent with species interaction hypotheses.

## 6 | CONCLUSION

Systematists are rapidly filling out our knowledge of the tree of life. In our view, many of the most exciting questions that we can address with relatively complete and well-supported phylogenetic trees involve species interactions. Species interactions have long been thought to be critical in microevolution and macroevolution alike, but their actual impacts on evolution have remained unclear. Unanswered questions have meant that many classic macroevolutionary ideas like adaptive radiation, escape-and-radiate, and others remain incompletely resolved. Great progress has been made so far using “methodological exaptations” to study the signature of species interactions on phylogenetic trees. A few relatively new approaches and syntheses are tailored specifically towards species interactions that might allow novel tests of critical biological hypotheses. Overall, we believe that model-based approaches will spur progress on a number of fundamental questions involving species interactions. In particular, we need approaches that combine multiple variables and processes (e.g. biogeography, speciation, trait evolution, distribution range evolution), incorporate interactions and allow comparisons to various “neutral” models. For example, in community phylogenetics, most practitioners agree on the important processes: dispersal, vicariance, speciation, extinction, environmental filters, trait evolution and competition. However, we lack a single model that has all of those features. Integrative mathematical approaches will be very helpful in

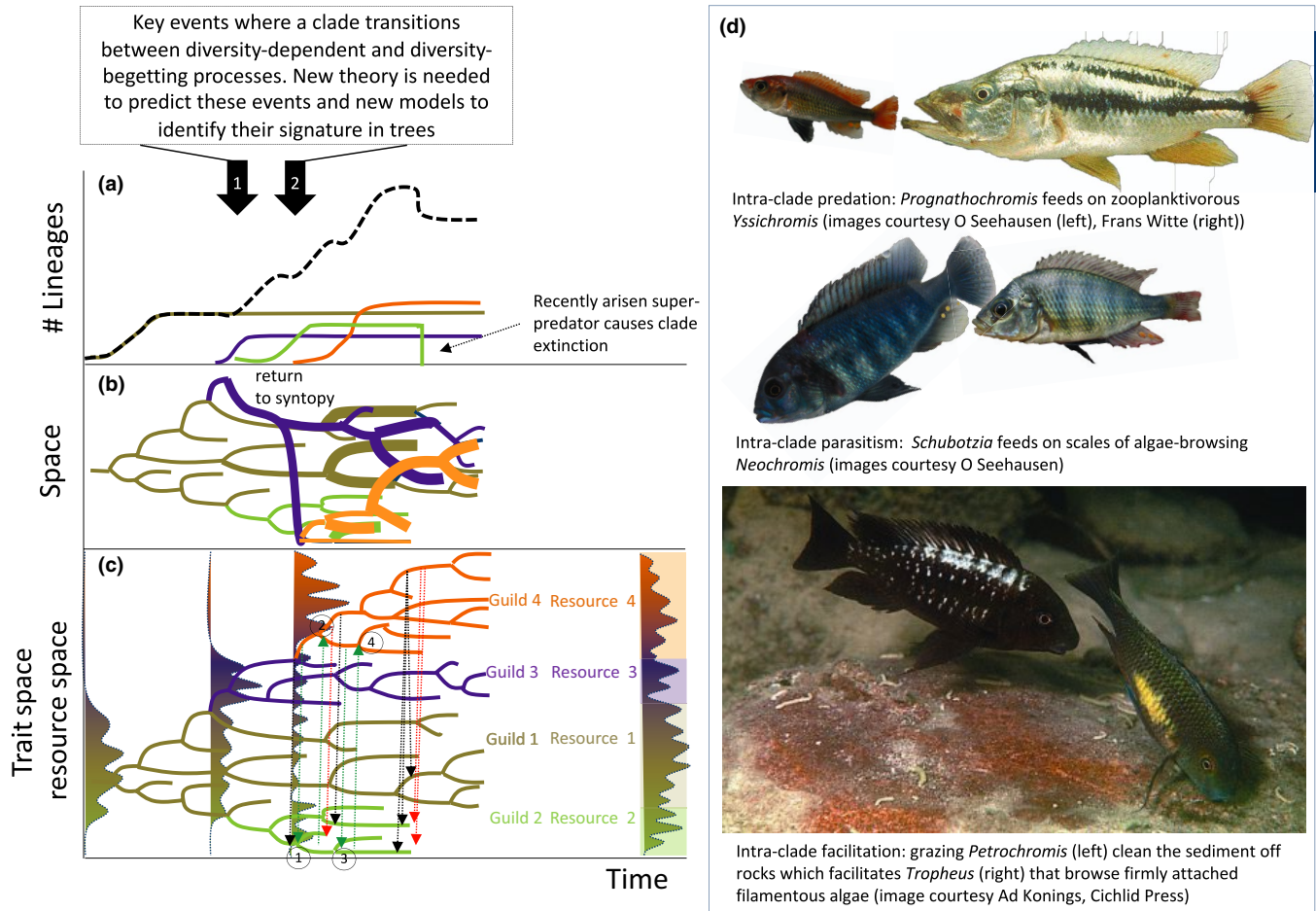

**FIGURE 4** A schematic illustration of a unifying theory for diversification and evolution of ecological interactions. In panel (a), the different colours correspond to the lineage through time plots (LTTs) for the entire clade and three subclades. In panels (b) and (c), lineages invaded a new adaptive subzone, expressed as time (x-axis) versus evolution in geographic (y-axis, panel b) and ecological and trait space (y-axis, panel c). In panel c, vertical distances between branches and tips indicate distances between species' trait and resource utilization means, which determine the intensity of species interactions. Hypothetical adaptive landscapes show the abundance distribution of resources accessible to the assemblage before (left), during (middle), and after radiation (right). Coloured backgrounds exemplify classes of dietary resources (1–4) that coincide with regions in trait space where trait values permit access to these resources. Predator–prey interactions among radiation members are indicated by hatched lines with different colours: black arrows indicate the beginning of a new interaction; green arrows indicate events of speciation in the prey species driven by predation pressure (arrows pointing down) and speciation in the predator in response to prey diversification (arrows pointing up); red down arrows indicate extinction events driven by predation. Finally, panel (d) shows three examples of noncompetitive intraclade species interactions that have evolved de novo within each of the large African Great Lake cichlid radiations. Top and middle examples are from the Lake Victoria region superflock; bottom is from the Lake Tanganyika Tropheini radiation

understanding these complex dynamics that structure communities over time and space.

## ACKNOWLEDGMENTS

We thank Eawag for hosting the workshop and the Swiss National Science Foundation for funding through International Exploratory Workshop “Interactions on Trees” (IZ32ZO\_166422) to CM, BM and OS. BM was supported by SNF grant 31003A\_153464. DS received funding from the Swedish Research Council (2015-04748) and from the Swedish Foundation for Strategic Research. SLN is funded by NSF DEB 1450653; LJH is funded by NSF DEB 1208912. FD is funded by ANR grant ANR-14-ACHN-0003-01. OS was supported by SNF grant 31003A\_163338.

## ORCID

Luke J. Harmon  <https://orcid.org/0000-0002-4985-5750>

Florence Débarre  <https://orcid.org/0000-0003-2497-833X>

Daniele Silvestro  <https://orcid.org/0000-0003-0100-0961>

## REFERENCES

- Abrams, P. A. (1986). Character displacement and niche shift analyzed using consumer-resource models of competition. *Theoretical Population Biology*, 29, 107–160.
- Abrams, P. A. (1996). Evolution and the consequences of species introductions and deletions. *Ecology*, 77, 1321–1328.
- Abrams, P. A., & Cortez, M. H. (2015). Is competition needed for ecological character displacement? Does displacement decrease competition? *Evolution*, 69, 3039–3053.

- Alcantara, S., & Lohmann, L. G. (2010). Evolution of floral morphology and pollination system in Bignoniaceae (Bignoniaceae). *American Journal of Botany*, *97*, 782–796.
- Allhoff, K. T., & Drossel, B. (2013). When do evolutionary food web models generate complex networks? *Journal of Theoretical Biology*, *334*, 122–129.
- Anacker, B. L., & Strauss, S. Y. (2014). The geography and ecology of plant speciation: Range overlap and niche divergence in sister species. *Proceedings. Biological sciences/The Royal Society*, *281*, 20132980.
- Anderson, B. (2015). *Coevolution in mutualisms. Mutualism*. Oxford, UK: Oxford University Press.
- Barracough, T. G., Vogler, A. P., & Harvey, P. H. (1998). Revealing the factors that promote speciation. *Philosophical Transactions of the Royal Society of London Series B, Biological Sciences*, *353*, 241–249.
- Bascompte, J., & Jordano, P. (2007). Plant-animal mutualistic networks: The architecture of biodiversity. *Annual Review of Ecology, Evolution, and Systematics*, *38*, 567–593.
- Bascompte, J., & Jordano, P. (2013). *Mutualistic networks*. Princeton, NJ: Princeton University Press.
- Becerra, J. X., Noge, K., & Venable, D. L. (2009). Macroevolutionary chemical escalation in an ancient plant–herbivore arms race. *Proceedings of the National Academy of Sciences of the United States of America*, *106*, 18062–18066.
- Bell, G. (2007). The evolution of trophic structure. *Heredity*, *99*, 494–505.
- Berenbaum, M., & Feeny, P. (1981). Toxicity of angular furanocoumarins to swallowtail butterflies: Escalation in a coevolutionary arms race? *Science*, *212*, 927–929.
- Berg, J., Lässig, M., & Wagner, A. (2004). Structure and evolution of protein interaction networks: A statistical model for link dynamics and gene duplications. *BMC Evolutionary Biology*, *4*, 51.
- Best, R. J., & Stachowicz, J. J. (2013). Phylogeny as a proxy for ecology in seagrass amphipods: Which traits are most conserved? *PLoS ONE*, *8*, e57550.
- Bienvenu, F., Débarre, F., & Lambert, A. (2018). The split-and-drift random graph, a null model for speciation. Stochastic processes and their applications.
- Bothwell, E., Montgomerie, R., Lougheed, S. C., & Martin, P. R. (2015). Closely related species of birds differ more in body size when their ranges overlap—in warm, but not cool, climates. *Evolution*, *69*, 1701–1712.
- Brockhurst, M. A., & Koskella, B. (2013). Experimental coevolution of species interactions. *Trends in Ecology & Evolution*, *28*, 367–375.
- Bronstein, J. L., Alarcón, R., & Geber, M. (2006). The evolution of plant–insect mutualisms. *The New Phytologist*, *172*, 412–428.
- Bruyndonckx, N., Dubey, S., Ruedi, M., & Christe, P. (2009). Molecular cophylogenetic relationships between European bats and their ectoparasitic mites (Acari, Spinturnicidae). *Molecular Phylogenetics and Evolution*, *51*, 227–237.
- Burns, J. H., & Strauss, S. Y. (2011). More closely related species are more ecologically similar in an experimental test. *Proceedings of the National Academy of Sciences of the United States of America*, *108*, 5302–5307.
- Campagna, L., Repenning, M., Silveira, L. F., Fontana, C. S., Tubaro, P. L., & Lovette, I. J. (2017). Repeated divergent selection on pigmentation genes in a rapid finch radiation. *Science Advances*, *3*, e1602404.
- Chase, J. M., & Leibold, M. A. (2003). *Ecological niches: Linking classical and contemporary approaches*. Chicago, IL: University of Chicago Press.
- Chung, F., Lu, L., Dewey, T. G., & Galas, D. J. (2003). Duplication models for biological networks. *Journal of Computational Biology*, *10*, 677–687.
- Clarke, M., Thomas, G. H., & Freckleton, R. P. (2017). Trait evolution in adaptive radiations: Modeling and measuring interspecific competition on phylogenies. *The American Naturalist*, *189*, 121–137.
- Cook, J. M., & Rasplus, J.-Y. (2003). Mutualists with attitude: Coevolving fig wasps and figs. *Trends in Ecology & Evolution*, *18*, 241–248.
- Davies, T. J., Jonathan Davies, T., Natalie, C., Diniz-Filho, J. A. F., Thomas, G. H., & Shai, M. (2012). Using phylogenetic trees to test for character displacement: A model and an example from a desert mammal community. *Ecology*, *93*, S44–S51.
- Davies, T. J., Meiri, S., Barraclough, T. G., & Gittleman, J. L. (2007). Species co-existence and character divergence across carnivores. *Ecology Letters*, *10*, 146–152.
- Dettman, J. R., Rodrigue, N., Melnyk, A. H., Wong, A., Bailey, S. F., & Kassen, R. (2012). Evolutionary insight from whole-genome sequencing of experimentally evolved microbes. *Molecular Ecology*, *21*, 2058–2077.
- Dobzhansky, T. (1950). Evolution in the tropics. *American Scientist*, *38*, 209–221.
- Drury, J., Clavel, J., Manceau, M., & Morlon, H. (2016). Estimating the effect of competition on trait evolution using maximum likelihood inference. *Systematic Biology*, *65*, 700–710.
- Drury, J. P., Tobias, J. A., Burns, K. J., Mason, N. A., Shultz, A. J., & Morlon, H. (2018). Contrasting impacts of competition on ecological and social trait evolution in songbirds. *PLoS Biology*, *16*, e2003563.
- Dunlap, P. V., Ast, J. C., Kimura, S., Fukui, A., Yoshino, T., & Endo, H. (2007). Phylogenetic analysis of host–symbiont specificity and codivergence in bioluminescent symbioses. *Cladistics*, *23*, 507–532.
- Dunne, J. A., Williams, R. J., Martinez, N. D., Wood, R. A., & Erwin, D. H. (2008). Compilation and network analyses of cambrian food webs. *PLoS Biology*, *6*, e102.
- de Vienne, D. M., Refrégier, G., López-Villavicencio, M., Tellier, A., Hood, M. E., & Giraud, T. (2013). Cospeciation vs host-shift speciation: Methods for testing, evidence from natural associations and relation to coevolution. *The New Phytologist*, *198*, 347–385.
- Ehrlich, P. R., & Raven, P. H. (1964). Butterflies and plants: A study in coevolution. *Evolution*, *18*, 586–608.
- Eldredge, N., Thompson, J. N., Brakefield, P. M., Gavrilets, S., Jablonski, D., Jackson, J. B. C., ... Miller, W. (2005). The dynamics of evolutionary stasis. *Paleobiology*, *31*, 133–145.
- Emmerson, M., & Yearsley, J. M. (2004). Weak interactions, omnivory and emergent food-web properties. *Proceedings. Biological Sciences/The Royal Society*, *271*, 397–405.
- Espinoza, R. E., Wiens, J. J., & Tracy, C. R. (2004). Recurrent evolution of herbivory in small, cold-climate lizards: Breaking the ecophysiological rules of reptilian herbivory. *Proceedings of the National Academy of Sciences of the United States of America*, *101*, 16819–16824.
- Etienne, R. S., & Haegeman, B. (2012). A conceptual and statistical framework for adaptive radiations with a key role for diversity dependence. *The American Naturalist*, *180*, E75–E89.
- Etienne, R. S., & Rosindell, J. (2012). Prolonging the past counteracts the pull of the present: Protracted speciation can explain observed slowdowns in diversification. *Systematic Biology*, *61*, 204–213.
- Evlampiev, K., & Isambert, H. (2008). Conservation and topology of protein interaction networks under duplication–divergence evolution. *Proceedings of the National Academy of Sciences of the United States of America*, *105*, 9863–9868.
- Farrell, B. D., Dussourd, D. E., & Mitter, C. (1991). Escalation of plant defense: Do latex and resin canals spur plant diversification? *The American Naturalist*, *138*, 881–900.
- FitzJohn, R. G. (2012). Diversitree: Comparative phylogenetic analyses of diversification in R. *Methods in Ecology and Evolution/British Ecological Society*, *3*, 1084–1092.
- Fox, J. W., & Vasseur, D. A. (2008). Character convergence under competition for nutritionally essential resources. *The American Naturalist*, *172*, 667–680.
- Freckleton, R. P., & Harvey, P. H. (2006). Detecting non-Brownian trait evolution in adaptive radiations. *PLoS Biology*, *4*, e373.
- Freeman, B. G. (2015). Competitive interactions upon secondary contact drive elevational divergence in tropical birds. *The American Naturalist*, *186*, 470–479.

- Futuyma, D. J. (2017). Evolutionary biology today and the call for an extended synthesis. *Interface Focus*, 7, 20160145.
- Germain, R. M., Weir, J. T., & Gilbert, B. (2016). Species coexistence: Macroevolutionary relationships and the contingency of historical interactions. *Proceedings. Biological Sciences/The Royal Society*, 283, 20160047.
- Germain, R. M., Williams, J. L., Schluter, D., & Angert, A. L. (2018). Moving character displacement beyond characters using contemporary coexistence theory. *Trends in Ecology & Evolution*, 33, 74–84.
- Gilinsky, N. L., & Bambach, R. K. (1987). Asymmetrical patterns of origination and extinction in higher taxa. *Paleobiology*, 13, 427–445.
- Goater, T. M., Goater, C. P., & Esch, G. W. (2013). *Parasitism: The diversity and ecology of animal parasites*. Cambridge, UK: Cambridge University Press.
- Godoy, O., Kraft, N. J. B., & Levine, J. M. (2014). Phylogenetic relatedness and the determinants of competitive outcomes. *Ecology Letters*, 17, 836–844.
- Goldberg, E. E., Lancaster, L. T., & Ree, R. H. (2011). Phylogenetic inference of reciprocal effects between geographic range evolution and diversification. *Systematic Biology*, 60, 451–465.
- Govaert, L., Fronhofer, E. A., Lion, S., Eizaguirre, C., Bonte, D., Egas, M., ... Matthews, B. (2018). Eco-evolutionary feedbacks—Theoretical models and perspectives (C. Fox, ed.). *Functional Ecology*, 29, 107.
- Grant, P. R., & Grant, R. B. (2011). *How and why species multiply: The radiation of Darwin's finches*. Princeton, NJ: Princeton University Press.
- Grossenbacher, D. L., & Whittall, J. B. (2011). Increased floral divergence in sympatric monkeyflowers. *Evolution*, 65, 2712–2718.
- Hafner, M. S., Demastes, J. W., & Spradling, T. A. (2003). *Cophylogeny between pocket gophers and chewing lice*. Chicago, IL: University of Chicago.
- Hansen, T. F., & Houle, D. (2004). Evolvability, stabilizing selection, and the problem of stasis. in Massimo Pigliucci And, ed. *Phenotypic Integration: Studying the Ecology and Evolution of Complex Phenotypes*. books.google.com.
- Harmon, L. J., & Harrison, S. (2015). Species diversity is dynamic and unbounded at local and continental scales. *The American Naturalist*, 185, 584–593.
- Hinchliff, C. E., Smith, S. A., Allman, J. F., Burleigh, J. G., Chaudhary, R., Coghill, L. M., ... Cranston, K. A. (2015). Synthesis of phylogeny and taxonomy into a comprehensive tree of life. *Proceedings of the National Academy of Sciences of the United States of America*, 112, 12764–12769.
- Hodges, S. A. (1997). Floral nectar spurs and diversification. *International Journal of Plant Sciences*, 158, S81–S88.
- Hubbell, S. P. (2006). Neutral theory and the evolution of ecological equivalence. *Ecology*, 87, 1387–1398.
- Huelsenbeck, J. P., Rannala, B., & Larget, B. (2000). A Bayesian framework for the analysis of cospeciation. *Evolution*, 54, 352–364.
- Hutchinson, M. C., Gaiarsa, M. P., & Stouffer, D. B. (2018). Contemporary ecological interactions improve models of past trait evolution. *Systematic Biology*, 67, 861–872.
- Jablonski, D. (2008). Biotic interactions and macroevolution: Extensions and mismatches across scales and levels. *Evolution*, 62, 715–739.
- Jones, C. G., Lawton, J. H., & Shachak, M. (1997). Positive and negative effects of organisms as physical ecosystem engineers. *Ecology*, 78, 1946–1957.
- Jousselin, E., & Van Noort, S. (2006). Patterns of diversification of Afrotropical Otiteselline fig wasps: Phylogenetic study reveals a double radiation across host figs and conservatism of host. *Journal of Evolutionary Biology*, 19, 253–266.
- Jousselin, E., van Noort, S., Berry, V., Rasplus, J.-Y., Rønsted, N., Erasmus, J. C., & Greeff, J. M. (2008). One fig to bind them all: Host conservatism in a fig wasp community unraveled by cospeciation analyses among pollinating and nonpollinating fig wasps. *Evolution*, 62, 1777–1797.
- Kloesener, M. H., Bose, J., & Schulte, R. D. (2017). Experimental evolution with a multicellular host causes diversification within and between microbial parasite populations—Differences in emerging phenotypes of two different parasite strains. *Evolution*, 71, 2194–2205.
- Krapivsky, P. L., & Redner, S. (2005). Network growth by copying. *Physical review. E, Statistical, nonlinear, and soft matter physics* 71:036118.
- Krasnov, B. R., Fortuna, M. A., Mouillot, D., Khokhlova, I. S., Shenbrot, G. I., & Poulin, R. (2012). Phylogenetic signal in module composition and species connectivity in compartmentalized host-parasite networks. *The American Naturalist*, 179, 501–511.
- Lamichhane, S., Berglund, J., Almén, M. S., Maqbool, K., Grabherr, M., Martínez-Barrio, A., ... Andersson, L. (2015). Evolution of Darwin's finches and their beaks revealed by genome sequencing. *Nature*, 518, 371–375.
- Lamichhane, S., Han, F., Webster, M. T., Andersson, L., Grant, B. R., & Grant, P. R. (2018). Rapid hybrid speciation in Darwin's finches. *Science*, 359, 224–228.
- Liow, L. H., Di Martino, E., Krzeminska, M., Ramsfjell, M., Rust, S., Taylor, P. D., & Voje, K. L. (2017). Relative size predicts competitive outcome through 2 million years. *Ecology Letters*, 20, 981–988.
- Livne-Luzon, S., Ovadia, O., Weber, G., Avidan, Y., Migael, H., Glassman, S. I., ... Shemesh, H. (2017). Small-scale spatial variability in the distribution of ectomycorrhizal fungi affects plant performance and fungal diversity. *Ecology Letters*, 20, 1192–1202.
- Loeuille, N., & Loreau, M. (2005). Evolutionary emergence of size-structured food webs. *Proceedings of the National Academy of Sciences of the United States of America*, 102, 5761–5766.
- Long, A., Liti, G., Luptak, A., & Tenaillon, O. (2015). Elucidating the molecular architecture of adaptation via evolve and resequence experiments. *Nature Reviews. Genetics*, 16, 567–582.
- Losos, J. B. (1990). A phylogenetic analysis of character displacement in *Caribbean anolis* lizards. *Evolution*, 44, 558.
- Losos, J. B. (2007). Detective work in the west indies: Integrating historical and experimental approaches to study island lizard evolution. *BioScience*, 57, 585–597.
- Losos, J. B., & Glor, R. E. (2003). Phylogenetic comparative methods and the geography of speciation. *Trends in Ecology & Evolution*, 18, 220–227.
- Maddison, W. P., & FitzJohn, R. G. (2015). The unsolved challenge to phylogenetic correlation tests for categorical characters. *Systematic Biology*, 64, 127–136.
- Maddison, W. P., Midford, P. E., & Otto, S. P. (2007). Estimating a binary character's effect on speciation and extinction. *Systematic Biology*, 56, 701–710.
- Maherali, H., & Klironomos, J. N. (2012). Phylogenetic and trait-based assembly of arbuscular mycorrhizal fungal communities. *PLoS ONE*, 7, e36695.
- Mahler, D. L., Luke Mahler, D., Revell, L. J., Glor, R. E., & Losos, J. B. (2010). Ecological opportunity and the rate of morphological evolution in the diversification of greater Antillean anoles. *Evolution*, 64, 2731–2745.
- Manceau, M., Lambert, A., & Morlon, H. (2016). A unifying comparative phylogenetic framework including traits coevolving across interacting lineages. *Systematic Biology*, 66(4), 551–568.
- Matthews, B., De Meester, L., Jones, C. G., Ibelings, B. W., Bouma, T. J., Nuutinen, V., ... Odling-Smee, J. (2014). Under niche construction: An operational bridge between ecology, evolution, and ecosystem science. *Ecological Monographs*, 84, 245–263.
- Mayfield, M. M., & Levine, J. M. (2010). Opposing effects of competitive exclusion on the phylogenetic structure of communities. *Ecology Letters*, 13, 1085–1093.
- McGee, M. D., Borstein, S. R., Neches, R. Y., Buescher, H. H., Seehausen, O., & Wainwright, P. C. (2015). A pharyngeal jaw evolutionary innovation facilitated extinction in Lake Victoria cichlids. *Science*, 350, 1077–1079.

- McPeck, M. A. (1996). Linking local species interactions to rates of speciation in communities. *Ecology*, *77*, 1355–1366.
- Meiners, J. M., Griswold, T. L., Harris, D. J., & Ernest, S. K. M. (2017). Bees without flowers: Before peak bloom, diverse native bees find insect-produced honeydew sugars. *The American Naturalist*, *190*, 281–291.
- Melián, C. J., Matthews, B., de Andreazzi, C. S., Rodríguez, J. P., Harmon, L. J., & Fortuna, M. A. (2018). Deciphering the interdependence between ecological and evolutionary networks. *Trends in Ecology & Evolution*, *33*, 504–512.
- Mitter, C., Farrell, B., & Wiegmann, B. (1988). The phylogenetic study of adaptive zones: Has phytophagy promoted insect diversification? *The American Naturalist*, *132*, 107–128.
- Morales-Castilla, I., Matias, M. G., Gravel, D., & Araújo, M. B. (2015). Inferring biotic interactions from proxies. *Trends in Ecology & Evolution*, *30*, 347–356.
- Moser, F. N., van, Rijssel, J. C., Mwaiko, S., Meier, J. I., Ngatunga, B., & Seehausen, O. (2018). The onset of ecological diversification 50 years after colonization of a crater lake by haplochromine cichlid fishes. *Proceedings. Biological Sciences/The Royal Society* *285*: 20180171.
- Mouquet, N., Devictor, V., Meynard, C. N., Munoz, F., Bersier, L. F., Chave, J., ... Thuiller, W. (2012). Ecophylogenetics: Advances and perspectives. *Biological Reviews of the Cambridge Philosophical Society*, *87*, 769–785.
- Muschick, M., Russell, J. M., Jemmi, E., Walker, J., Stewart, K. M., Murray, A. M., ... Seehausen, O. (2018). Arrival order and release from competition does not explain why haplochromine cichlids radiated in Lake Victoria. *Proceedings. Biological Sciences/The Royal Society*, *285*, 20180462.
- Narwani, A., Alexandrou, M. A., Oakley, T. H., Carroll, I. T., & Cardinale, B. J. (2013). Experimental evidence that evolutionary relatedness does not affect the ecological mechanisms of coexistence in freshwater green algae. *Ecology Letters*, *16*, 1373–1381.
- Narwani, A., Matthews, B., Fox, J., & Venail, P. (2015). Using phylogenetics in community assembly and ecosystem functioning research. *Functional Ecology*, *29*, 589–591.
- Newman, M. (2010). *Networks: An introduction*. Oxford, UK: OUP Oxford.
- Nuismer, S. (2017). *Introduction to coevolutionary theory*. New York, NY: Macmillan Higher Education.
- Nuismer, S. L., & Harmon, L. J. (2015). Predicting rates of interspecific interaction from phylogenetic trees. *Ecology Letters*, *18*, 17–27.
- Odling-Smee, J., Erwin, D. H., Palkovacs, E. P., Feldman, M. W., & Laland, K. N. (2013). Niche construction theory: A practical guide for ecologists. *The Quarterly Review of Biology*, *88*, 4–28.
- Page, R. D. M. (2003). *Tangled trees: Phylogeny, cospeciation, and coevolution*. *Tangled trees: Phylogeny, cospeciation, and coevolution*. Chicago, IL: University of Chicago Press.
- Pascual, M., & Dunne, J. A. (2006). Ecological networks: Linking structure to dynamics in food webs. Proceedings volume in the Santa Fe Institute studies in the sciences of complexity. Oxford University Press, USA.
- Penczykowski, R. M., Laine, A.-L., & Koskella, B. (2016). Understanding the ecology and evolution of host-parasite interactions across scales. *Evolutionary Applications*, *9*, 37–52.
- Pennell, M. W., & Harmon, L. J. (2013). An integrative view of phylogenetic comparative methods: Connections to population genetics, community ecology, and paleobiology. *Annals of the New York Academy of Sciences*, *1289*, 90–105.
- Peralta, G. (2016). Merging evolutionary history into species interaction networks. *Functional Ecology*, *30*, 1917–1925.
- Piercey-Normore, M. D., & Depriest, P. T. (2001). Algal switching among lichen symbioses. *American Journal of Botany*, *88*, 1490–1498.
- Pimm, S. L. (1982). *Food webs. Population and community biology*. London, UK: Springer Netherlands.
- Pires, M. M., Silvestro, D., & Quental, T. B. (2017). Interactions within and between clades shaped the diversification of terrestrial carnivores. *Evolution*, *71*, 1855–1864.
- Poisot, T., & Stouffer, D. (2016). How ecological networks evolve. *bioRxiv*.
- Poniso, L. C., Gaiarsa, M. P., & Kremen, C. (2017). Opportunistic attachment assembles plant-pollinator networks. *Ecology Letters*, *20*, 1261–1272.
- Pybus, O. G., & Harvey, P. H. (2000). Testing macro-evolutionary models using incomplete molecular phylogenies. *Proceedings. Biological Sciences/The Royal Society*, *267*, 2267–2272.
- Quental, T. B., & Marshall, C. R. (2010). Diversity dynamics: Molecular phylogenies need the fossil record. *Trends in Ecology & Evolution*, *25*, 434–441.
- Quental, T. B., & Marshall, C. R. (2013). How the Red Queen drives terrestrial mammals to extinction. *Science*, *341*, 290–292.
- Rabosky, D. L. (2013). Diversity-dependence, ecological speciation, and the role of competition in macroevolution. *Annual Review of Ecology, Evolution, and Systematics*, *44*, 481–502.
- Rabosky, D. L., & Glor, R. E. (2010). Equilibrium speciation dynamics in a model adaptive radiation of island lizards. *Proceedings of the National Academy of Sciences of the United States of America*, *107*, 22178–22183.
- Rabosky, D. L., & Hurlbert, A. H. (2015). Species richness at continental scales is dominated by ecological limits. *The American Naturalist*, *185*, 572–583.
- Rasmann, S., Sergio, R., & Agrawal, A. A. (2011). Latitudinal patterns in plant defense: Evolution of cardenolides, their toxicity and induction following herbivory. *Ecology Letters*, *14*, 476–483.
- Rezende, E. L., Jordano, P., & Bascompte, J. (2007a). Effects of phenotypic complementarity and phylogeny on the nested structure of mutualistic networks. *Oikos*, *116*, 1919–1929.
- Rezende, E. L., Lavabre, J. E., Guimarães, P. R., Jordano, P., & Bascompte, J. (2007b). Non-random coextinctions in phylogenetically structured mutualistic networks. *Nature*, *448*, 925–928.
- Rice, W. R., & Hostert, E. E. (1993). Laboratory experiments on speciation: What have we learned in 40 years? *Evolution*, *47*, 1637–1653.
- Ritchie, M. G. (2007). Sexual selection and speciation. *Annual Review of Ecology, Evolution, and Systematics*, *38*, 79–102.
- Rohr, R. P., & Bascompte, J. (2014). Components of phylogenetic signal in antagonistic and mutualistic networks. *The American Naturalist*, *184*, 556–564.
- Roopnarine, P. D. (2006). Extinction cascades and catastrophe in ancient food webs. *Paleobiology*, *32*, 1–19.
- Rosindell, J., Hubbell, S. P., He, F., Harmon, L. J., & Etienne, R. S. (2012). The case for ecological neutral theory. *Trends in Ecology & Evolution*, *27*, 203–208.
- Salzburger, W. (2018). Understanding explosive diversification through cichlid fish genomics. *Nature Reviews. Genetics*, *19*, 705–717.
- Schemske, D. W., Mittelbach, G. G., Cornell, H. V., Sobel, J. M., & Roy, K. (2009). Is there a latitudinal gradient in the importance of biotic interactions? *Annual Review of Ecology, Evolution, and Systematics*, *40*, 245–269.
- Schluter, D. (2000a). *The ecology of adaptive radiation*. Oxford, UK: Oxford University Press.
- Schluter, D. (2000b). Ecological character displacement in adaptive radiation. *The American Naturalist*, *156*, S4–S16.
- Schoener, T. W. (2011). The newest synthesis: Understanding the interplay of evolutionary and ecological dynamics. *Science*, *331*, 426–429.
- Schweizer, M., Güntert, M., Seehausen, O., Leuenberger, C., & Hertz, S. T. (2014). Parallel adaptations to nectarivory in parrots, key innovations and the diversification of the Loriinae. *Ecology and evolution*, *4*(14), 2867–2883.
- Seehausen, O. (2015a). Process and pattern in cichlid radiations—implications for understanding unusually high rates of evolutionary diversification. *The New Phytologist*, *207*(2), 304–312.

- Seehausen, O. (2015b). Process and pattern in cichlid radiations - inferences for understanding unusually high rates of evolutionary diversification. *The New Phytologist*, 207, 304–312.
- Sepkoski, J. J. (1981). A factor analytic description of the phanerozoic marine fossil record. *Paleobiology*, 7, 36–53.
- Silvestro, D., Antonelli, A., Salamin, N., & Quental, T. B. (2015). The role of clade competition in the diversification of North American canids. *Proceedings of the National Academy of Sciences of the United States of America*, 112, 8684–8689.
- Simpson, G. G. (1945). Tempo and mode in evolution. *Transactions of the New York Academy of Sciences*, 8, 45–60.
- Slater, G. J., Harmon, L. J., Wegmann, D., Joyce, P., Revell, L. J., & Alfaro, M. E. (2012). Fitting models of continuous trait evolution to incompletely sampled comparative data using approximate Bayesian computation. *Evolution*, 66, 752–762.
- Stachowicz, J. J. (2001). Mutualism, facilitation, and the structure of ecological communities positive interactions play a critical, but underappreciated, role in ecological communities. *BioScience*, 51(3), 235.
- Stanley, S. M. (1979). Macroevolution, pattern and process.
- Sukumaran, J., Economo, E. P., & Lacey Knowles, L. (2016). Machine learning biogeographic processes from biotic patterns: A new trait-dependent dispersal and diversification model with model choice by simulation-trained discriminant analysis. *Systematic Biology*, 65, 525–545.
- Tanentzap, A. J., Brandt, A. J., Smissen, R. D., Heenan, P. B., Fukami, T., & Lee, W. G. (2015). When do plant radiations influence community assembly? The importance of historical contingency in the race for niche space. *The New Phytologist*, 207, 468–479.
- Thompson, J. N. (1994). *The coevolutionary process*. Chicago, IL: University of Chicago Press.
- Thompson, J. N. (1999). The evolution of species interactions. *Science*, 284, 2116–2118.
- Thompson, J. N. (2005). *The geographic mosaic of coevolution. Interspecific interactions*. Chicago, IL: University of Chicago Press.
- Tilman, D. (1982). Resource competition and community structure. *Monographs in Population Biology*, 17, 1–296.
- Tobler, R., Franssen, S. U., Kofler, R., Orozco-Terwengel, P., Nolte, V., Hermisson, J., & Schlötterer, C. (2014). Massive habitat-specific genomic response in *D. melanogaster* populations during experimental evolution in hot and cold environments. *Molecular Biology and Evolution*, 31, 364–375.
- Tucker, C. M., Davies, T. J., Cadotte, M. W., & Pearse, W. D. (2018). On the relationship between phylogenetic diversity and trait diversity. *Ecology*, 99, 1473–1479.
- Turcotte, M. M., Corrin, M. S. C., & Johnson, M. T. J. (2012). Adaptive evolution in ecological communities. *PLoS Biology*, 10, e1001332.
- Turcotte, M. M., Davies, T. J., Thomsen, C. J. M., & Johnson, M. T. J. (2014). Macroecological and macroevolutionary patterns of leaf herbivory across vascular plants. *Proceedings. Biological Sciences/The Royal Society*, 281, 20140555.
- Turner, T. L., Stewart, A. D., Fields, A. T., Rice, W. R., & Tarone, A. M. (2011). Population-based resequencing of experimentally evolved populations reveals the genetic basis of body size variation in *Drosophila melanogaster*. *PLoS Genetics*, 7, e1001336.
- Valiente-Banuet, A., & Verdú, M. (2007). Facilitation can increase the phylogenetic diversity of plant communities. *Ecology Letters*, 10, 1029–1036.
- Van Valen, L. (1973). A new evolutionary law. *Evolutionary Theory*, 1, 1–30.
- Vázquez, A., Flammini, A., Maritan, A., & Vespignani, A. (2002). Modeling of protein interaction networks. *Complexity*, 1, 38–44.
- Vermeij, G. J. (1994). The evolutionary interaction among species: Selection, escalation, and coevolution. *Annual Review of Ecology and Systematics*, 25, 219–236.
- Wagner, C. E., Harmon, L. J., & Seehausen, O. (2014). Cichlid species-area relationships are shaped by adaptive radiations that scale with area. *Ecology Letters*, 17, 583–592.
- Warren, D. L., Cardillo, M., Rosauer, D. F., & Bolnick, D. I. (2014). Mistaking geography for biology: Inferring processes from species distributions. *Trends in Ecology & Evolution*, 29, 572–580.
- Webb, C. O., Ackerly, D. D., McPeck, M. A., & Donoghue, M. J. (2002). Phylogenies and community ecology. *Annual Review of Ecology and Systematics*, 33, 475–505.
- Weber, M. G., & Agrawal, A. A. (2012). Phylogeny, ecology, and the coupling of comparative and experimental approaches. *Trends in Ecology & Evolution*, 27, 394–403.
- Weber, M. G., & Agrawal, A. A. (2014). Defense mutualisms enhance plant diversification. *Proceedings of the National Academy of Sciences of the United States of America*, 111, 16442–16447.
- Weber, M. G., Cacho, N. I., Phan, M. J. Q., Disbrow, C., Ramirez, S. R., & Strauss, S. Y. (2018). The evolution of floral signals in relation to range overlap in a clade of California Jewelflowers (*Streptanthus* s.l.). *Evolution*, 72, 798–807.
- Weber, M. G., Wagner, C. E., Best, R. J., Harmon, L. J., & Matthews, B. (2017). Evolution in a community context: On integrating ecological interactions and macroevolution. *Trends in Ecology & Evolution*, 32, 291–304.
- Week, B., & Nuismer, S. L. (2019). The measurement of coevolution in the wild. *Ecology Letters*, 22(4), 717–725.
- Weissing, F. J., Edelaar, P., & van Doorn, G. S. (2011). Adaptive speciation theory: A conceptual review. *Behavioral Ecology and Sociobiology*, 65, 461–480.
- Whittall, J. B., & Hodges, S. A. (2007). Pollinator shifts drive increasingly long nectar spurs in columbine flowers. *Nature*, 447, 706–709.
- Wootton, J. T., & Emmerson, M. (2005). Measurement of interaction strength in nature. *Annual Review of Ecology, Evolution, and Systematics*, 36, 419–444.
- Yoder, J. B., Clancey, E., Des Roches, S., Eastman, J. M., Gentry, L., Godsoe, W., ... Harmon, L. J. (2010). Ecological opportunity and the origin of adaptive radiations. *Journal of Evolutionary Biology*, 23, 1581–1596.
- Yoder, J. L., & Nuismer, S. L. (2010). When does coevolution promote diversification? *The American Naturalist*, 176, 802–817.
- Yoshida, K. (2003). Evolutionary dynamics of species diversity in an interaction web system. *Ecological Modelling*, 163, 131–143.

**How to cite this article:** Harmon LJ, Andreazzi CS, Débarre F, et al. Detecting the macroevolutionary signal of species interactions. *J Evol Biol*. 2019;32:769–782. <https://doi.org/10.1111/jeb.13477>