



HAL
open science

Recommended approaches to minimize aerosol dispersion of SARS-CoV2 during noninvasive ventilatory support can deteriorate ventilator performances: a benchmark comparative study Running head: COVID19-specific montage alters ventilator performances

Maxime Patout, Emeline Fresnel Phd, Manuel Lujan, Claudio Rabec, Annalisa Carlucci, Léa Razakamanantsoa, Adrien Kerfourn Phd, Hilario Nunes, Yacine Tandjaoui-Lambiotte, Antoine Cuvelier, et al.

► **To cite this version:**

Maxime Patout, Emeline Fresnel Phd, Manuel Lujan, Claudio Rabec, Annalisa Carlucci, et al.. Recommended approaches to minimize aerosol dispersion of SARS-CoV2 during noninvasive ventilatory support can deteriorate ventilator performances: a benchmark comparative study Running head: COVID19-specific montage alters ventilator performances. Chest, 2021, 10.1016/j.chest.2021.02.047 . hal-03163975

HAL Id: hal-03163975

<https://hal.sorbonne-universite.fr/hal-03163975v1>

Submitted on 9 Mar 2021

HAL is a multi-disciplinary open access archive for the deposit and dissemination of scientific research documents, whether they are published or not. The documents may come from teaching and research institutions in France or abroad, or from public or private research centers.

L'archive ouverte pluridisciplinaire **HAL**, est destinée au dépôt et à la diffusion de documents scientifiques de niveau recherche, publiés ou non, émanant des établissements d'enseignement et de recherche français ou étrangers, des laboratoires publics ou privés.

1 Word count: 2859

2

3 **Recommended approaches to minimize aerosol dispersion of SARS-CoV2 during noninvasive**
4 **ventilatory support can deteriorate ventilator performances: a benchmark comparative study**

5 *Running head: COVID19-specific montage alters ventilator performances*

6

7 Maxime Patout MD PhD^{1,2,3,4}, Emeline Fresnel PhD^{4,5}, Manuel Lujan MD PhD⁶, Claudio Rabec^{7,8} MD,

8 Annalisa Carlucci MD PhD^{9,10}, Léa Razakamanantsoa MD⁴, Adrien Kerfourn PhD^{4,5} Hilario Nunes MD

9 PhD^{3,11}, Yacine Tandjaoui-Lambiotte MD ^{11,12}, Antoine Cuvelier MD PhD⁵, Jean-François Muir MD

10 PhD^{4,8}, Cristina Lalmoda MD⁶, Bruno Langevin MD¹³, Javier Sayas MD PhD¹⁴, Jesus Gonzalez-

11 Bermejo MD PhD^{2,15}, Jean-Paul Janssens MD ¹⁶ on behalf of the SomnoNIV group

12

13 1. AP-HP, Groupe Hospitalier Universitaire APHP-Sorbonne Université, site Pitié-Salpêtrière,
14 Service des Pathologies du Sommeil (Département R3S), F-75013 Paris, France

15 2. Sorbonne Université, INSERM, UMRS1158 Neurophysiologie Respiratoire Expérimentale et
16 Clinique, F-75005 Paris, France

17 3. Respiratory Department, Avicenne Hospital, AP-HP, Bobigny, France

18 4. Normandie Univ, UNIRouen, EA3830-GRHV, Institute for Research and Innovation in
19 Biomedicine (IRIB), Rouen, France

20 5. Kernel Biomedical, Bois-Guillaume, France

21 6. Pneumology Department, Corporació Sanitaria Parc Taulí, Sabadell, Barcelona, Spain

22 7. Pulmonary Department and Respiratory Critical Care Unit, University Hospital Dijon, Dijon,
23 France.

24 8. Fédération ANTADIR, Paris, France

25 9. Pulmonary Rehabilitation Istituti Clinici Scientifici Maugeri-Pavia-Italy

26 10. Department of Medicine University of Insubria Varese-Como, Italy

27 11. INSERM U1272 “Hypoxia & the Lung”, Paris 13 University, Bobigny, France

28 12. Intensive Care Unit, Avicenne Hospital, AP-HP, Bobigny, France

29 13. Réanimation, Pôle soins aigus, Centre Hospitalier Alès, Alès, France.

30 14. Servicio de Neumología, Hospital Universitario 12 de Octubre, Madrid, España

31 15. AP-HP, Groupe Hospitalier Universitaire APHP-Sorbonne Université, site Pitié-
32 Salpêtrière, Service de Pneumologie, Médecine Intensive et Réanimation (Département R3S),
33 F-75013 Paris, France

34 16. Division of Pulmonary Diseases, Geneva University Hospitals (HUG), Switzerland; Faculty of
35 Medicine, University of Geneva, Switzerland

36

37 **Corresponding author**

38 Dr. Maxime Patout

39 AP-HP, Groupe Hospitalier Universitaire APHP-Sorbonne Université, site Pitié-Salpêtrière, Service des
40 Pathologies du Sommeil (Département R3S) Paris, France

41 47-83 boulevard de l'hôpital,

42 75013, Paris, France

43 maxime.patout@aphp.fr

44

45 **Summary conflict of interest statements**

46 MP reports personal fees from Resmed, Philips Respironics, grants and non-financial support from
47 Fisher & Paykel, nonfinancial support and personal fees from Asten, research grants from B&D
48 Electromedical and Fisher & Paykel, personal fees and non-financial support from Chiesi outside the
49 submitted work.

50 In the last 2 years JGB received fees from Philips, Resmed, Breas, Lowenstein and Air Liquide for
51 expertise, and a grant from BREAS for a trial, outside the submitted work.

52 JS reports advisory and teaching payments from Resmed, Philips, Chiesi and Menarini outside the
53 submitted work.

54 In the last two years, CR received fees from Philips, Resmed, Lowenstein and Fischer & Paykel for
55 expertise, outside the submitted work.

56 EF, AK, LR, AC, CL, BL, ML, AC, JFM, HN, YTL reports no competing interest

57

58 **Funding**

59 Funding was provided by ADIR Association. Asten Santé provided ventilator, filters, masks and circuits
60 used in the trial.

61 **Abbreviation list**

62 CPAP: continuous positive airway pressure

63 HME: heat and moisture exchange

64 IQ: interquartile

65 NIV: noninvasive ventilation

66 PEEP: positive end-expiratory pressure

67 PTP: pressure time product

68 sPVA: simulated patient-ventilator asynchrony

69 V_t: tidal volume

70 WOB: work of breathing

71 **Abstract**

72 *Background:* SARS-CoV-2 aerosolization during noninvasive positive pressure ventilation may
73 endanger healthcare professionals. Various circuit setups have been described in order to reduce virus
74 aerosolization. However, these setups may alter ventilator performances.

75 *Research question:* What are the consequences of the different suggested circuit setups on ventilator's
76 efficacy during continuous positive airway pressure (CPAP) and noninvasive ventilation (NIV)?

77 *Study Design and Method:* Eight circuit setups were evaluated on a bench made of a 3-D printed head
78 and an artificial lung. Setups were a dual-limb circuit with an oro-nasal mask, a dual-limb circuit with a
79 helmet interface, a single-limb circuit with a passive exhalation valve, three single-limb circuits with
80 custom-made additional leaks and two single-limb circuits with active exhalation valves. All setups were
81 evaluated during NIV and CPAP. The following variables were recorded: the inspiratory flow preceding
82 trigger of the ventilator, the inspiratory effort required to trigger the ventilator, the triggering delay, the
83 maximal inspiratory pressure delivered by the ventilator, the tidal volume (V_t) generated to the artificial
84 lung, the total work of breathing (WOB) and the pressure time product to trigger the ventilator (PTPt).

85 *Results:* With NIV, the type of circuit setup had a significant impact on inspiratory flow preceding the
86 trigger of the ventilator ($p < 0.0001$), the inspiratory effort required to trigger the ventilator ($p < 0.0001$), the
87 triggering delay ($p < 0.0001$); the maximal inspiratory pressure ($p < 0.0001$), the V_t ($p: 0.0008$), the WOB
88 ($p < 0.0001$), the PTPt ($p < 0.0001$). Similar differences and consequences were seen with CPAP as well
89 as with the addition of bacterial filters. Best performance was achieved using a dual limb circuit with an
90 oro-nasal mask. Worst performance was achieved using a dual-limb circuit with a helmet interface.

91 *Interpretation:* Ventilator performance is significantly impacted by the circuit setup. The use of dual-limb
92 circuit with oro-nasal masks should be used preferentially.

93

94 **Introduction**

95 Patients with severe SARS-CoV-2 infection can receive respiratory support using high-flow nasal
96 therapy, continuous positive airway pressure (CPAP) ¹ or non-invasive ventilation (NIV) ². The use of
97 these treatments is associated with virus aerosolization ³ which may endanger caregivers ^{4,5}. For high-
98 flow therapy, surgical masks worn by patients can limit aerosolization ^{6,7}. During NIV or CPAP, surgical
99 masks cannot be worn. NIV and CPAP are usually delivered to patients using an interface with a built-
100 in intentional leak to avoid carbon dioxide re-breathing. Various strategies have been suggested by
101 experts in order to minimize the risk of aerosolization ^{5,8}. For CPAP and NIV, the use of non-vented
102 masks with the addition of another bacterial filter on the circuit has been suggested ⁹ in order to limit
103 aerosolization during expiration. These changes have been implemented using different circuit setups.

104

105 If reducing the risk of aerosolization is a priority in the management of patients with SARS-CoV-2
106 infection, we still need to deliver the best care possible to our patients. The addition of a second bacterial
107 filter in NIV/CPAP circuit is not the standard of care except when dual-limb circuit are used. The addition
108 of these filters may impact on the resistance of the circuit and increase patient's work of breathing. It
109 may also alter ventilator performance and generate patient-ventilator asynchrony which have a
110 deleterious impact in acute respiratory failure ^{10,11}.

111

112 Our hypothesis was that the use of these modifications on NIV/CPAP circuits altered ventilator
113 performances. Our aim was to assess the consequences of the different suggested circuit setups for
114 the management of SARS-CoV-2 infected patients on ventilator efficacy during CPAP and NIV.

115 **Study Design and Methods**

116 ***Experimental model***

117 We used a 3-D printed head mimicking human upper airways and trachea (Online supplement (OLS),
118 e-Figure 1). The 3-D printed head was designed using Zbrush 2019 (Pixologic, CA, USA) by Phoenix
119 Effect Studio (Rouen, France). The model was then printed using 3D-printers Raise3D Pro 2 et Raise3D
120 Pro 2 plus (Raise3D, CA, USA). The model had a dead space of 152 mL and a resistance of 2.4 cmH₂O.

121
122 We applied a non-vented oro-buccal mask (Quattro FX, ResMed, San Diego, CA, USA) on the head
123 and verified adequate fitting of the mask before each maneuver. We assessed one setup using a helmet
124 interface. In that case, we used a DimAirLine, NIMV 6R ZIT mask (Dimar, Medolla, Italy). Circuit setups
125 were evaluated with heat and moisture exchange (HME) filters (Inter-term, Intersurgical, Wokingham,
126 United Kingdom), with low-resistance bacterial filters (Iso-guard, Gibeck, Morrisville, NC, USA) or
127 without any filter. Eight circuit setups were evaluated during NIV and CPAP (Figure 1). Setup 4 used a
128 3D-printed piece designed by MP, EF and JGB for this purpose and freely available (e-Figure 2 -
129 <http://www.kernelbiomedical.com/3dleak>). With CPAP, we analyzed a 9th setup using a Boussignac
130 CPAP (Vygon, Ecoen, France). The Boussignac setup was only assessed using one circuit setup but
131 with the two-filter configuration.

132
133 The trachea was connected to an artificial lung (ASL-5000, Ingmar Medical, Pittsburgh, PA, USA).
134 Respiratory effort was simulated, with a drop in airway pressure at 100 ms (or P0.1) of 5 cmH₂O and a
135 breathing frequency of 30 bpm. This setting was chosen to match the respiratory mechanics seen during
136 SARS-CoV2 infections. The shape of the effort curve was a double exponential. This effort was
137 combined with three different lung mechanics conditions, reflecting the pulmonary function of the
138 simulated patients by modulating resistance (R) and compliance (C) parameters. We simulated a normal
139 lung condition with R = 5 cmH₂O/l.s and C = 60 ml/cmH₂O, during 20 cycles according to measurements
140 performed in patients with severe SARS-CoV-2 infection ¹²; a restrictive lung condition with R = 5
141 cmH₂O/l.s and C = 30 ml/cmH₂O, during 15 cycles and an obstructive lung condition with R = 25
142 cmH₂O/l.s and C = 60 ml/cmH₂O, during 15 cycles.

143

144 All experiments were conducted with an Astral 150 ventilator version 0601 (ResMed, San Diego, CA,
145 USA) without active humidification. Ventilator pre-tests were conducted before each experiment. The
146 ventilator was set as follow: inspiratory pressure: 16 cmH₂O, expiratory pressure: 8 cmH₂O, inspiratory
147 time window: 0.8 to 1.4s, rise time: 100ms, trigger sensitivity: high, cycling: 50% of the peak inspiratory
148 flow. With CPAP, the expiratory pressure was set at 8 cmH₂O. These settings were chosen according
149 to the clinical experience of the authors in the management of patients with severe SARS-CoV-2
150 infection. When CPAP was provided using a Boussignac CPAP (Vygon, Ecoen, France): pressure was
151 generated using 30 L/min of O₂.

152 **Measurements:**

153 Measurements were performed using the flow and pressure curves provided by the artificial lung (e-
154 figure 3).

155 For each cycle labelled as synchronized during NIV, we computed 7 indicators (Figure 3). We used four
156 indicators to characterize inspiratory trigger. The indicators were: triggering delay (ms) which measured
157 the time lag between the beginning of simulated effort and the onset of pressure support, flow to trigger
158 (L/min) defined as the value of patient flow measured at the onset of support pressure, pressure to
159 trigger (cmH₂O) defined as the value of muscular pressure P_{mus} measured at the onset of support
160 pressure and inspiratory pressure-time product (PTPt) (cmH₂O.s) defined as the area under the
161 pressure-time curve between the onset of inspiratory effort and the return to the set positive end-
162 expiratory pressure (PEEP) as described¹³. We used three indicators to characterize pressurization.
163 The indicators were: delivered inspiratory pressure (cmH₂O) defined as the peak pressure reached
164 during the inspiratory pressurization phase, tidal volume (ml) defined as the difference between the
165 maximal volume delivered within the current cycle to the mechanical lung and the residual volume and
166 total work of breathing of the system (WOB) (mJ) defined as the sum of the patient WOB (integral of
167 muscular pressure x flow product preceding the onset of ventilatory support) and ventilator WOB
168 (integral of airway pressure x flow product between onset of support and instant when 95% of the IPAP
169 level is reached during pressure rise time).

170

171 For each cycle labelled as asynchronized during NIV, we characterized the “simulated patient” ventilator
172 asynchrony events (sPVA) according to the framework proposed by the SomnoNIV group^{14,15}. We
173 distinguished rate asynchronies from intracycle asynchronies. Rate asynchronies were defined as a

174 mismatch between ventilator and patients' rates. We identified: ineffective efforts when an inspiratory
175 effort was not assisted by the ventilator (*ie.* a drop of airway pressure associated with an increase or
176 decrease of airflow occurring during expiratory or inspiratory phase respectively), double triggering when
177 two mechanical cycles were triggered by the patient, separated by a very short expiratory time (< 30%
178 of mean inspiratory time) and auto-triggering when mechanical cycles were unrelated to patient's
179 spontaneous breathing. Rate intracycle asynchronies were defined as a distortion of the flow and
180 pressure curves during inspiration and/or expiration. We identified premature cycling when the end of
181 the mechanical insufflation preceded the end of patient's inspiration and delayed cycling mechanical
182 insufflation exceeded the patient's own neural expiration. Each asynchrony event was expressed as a
183 percentage by dividing the number of asynchronous cycles by the total of simulated respiratory cycles.

184

185 During CPAP, the depression generated by the patient's inspiratory efforts is detected by the ventilator,
186 which regulates the pressure delivered accordingly. For each cycle breathing cycle, the following
187 indicators were computed (Figure 3): regulation delay (ms) which measured the time lag between the
188 start of simulated effort and the onset of pressure regulation, flow to regulation (L/min) corresponding to
189 the flow preceding the ventilator pressurization response, inspiratory pressure-time product (PTPt)
190 (cmH₂O.s) defined as the area under the pressure-time curve between the onset of inspiratory effort
191 and the onset of pressure regulation, the maximal delivered pressure (cmH₂O) defined as the peak
192 pressure reached during the current cycle and tidal volume (ml) defined as the difference between the
193 maximal volume delivered within the current cycle to the mechanical lung and the residual volume.

194

195 ***Statistical analysis***

196 Results are expressed as median and interquartile. Chi-square tests were used to compare categorical
197 variables. Kruskal-Wallis tests were used for comparison on continuous variables. Dunn's correction
198 was applied for multiple comparisons. When assessing the impact of a filter, we compared the absence
199 of filter to each filter type as well as the low resistance filter to HME filter. When assessing the impact of
200 circuits, setup 5 was used as reference. All tests were two-sided. For all tests, significance level was set
201 at 0.05. Statistical analysis was performed using Prism 9.0.0 (GraphPad Software, La Jolla, California,
202 USA).

203

204 **Results**

205 For each setup, 135 respiratory cycles were analyzed with NIV, and 150 with CPAP. Each experiment
206 was conducted with 3 different filter configurations: no filter, low pressure filter or HME filter. In total,
207 2,430 respiratory cycles were analyzed: 810 (33%) with a normal compliance and resistance profile,
208 810 (33%) with a low compliance and normal resistance profile and 810 (33%) with a normal compliance
209 and increased resistance profile.

210
211 With NIV, the addition of a low pressure and a HME filter had a significant impact on ventilator
212 performance. The addition of a filter (low pressure or HME) was associated with an increase in flow
213 preceding triggering ($p=0.0423$), inspiratory effort to trigger the ventilator ($p<0.0001$), triggering delay
214 ($p<0.0001$), WOB ($p<0.0001$) and PTPt ($p<0.001$) and a decrease in maximal inspiratory pressure
215 ($p<0.0001$), and V_t ($p<0.0001$). Percentage of sPVA was the only parameter for which adding a filter did
216 not cause a significant difference ($p=0.190$; eTable 1). No difference was seen between low pressure
217 and HME filters except for PTPt which was higher using an HME filter ($p=0.0136$) (Table 1 and Figure
218 4). Similar results were seen with CPAP: albeit for inspiratory flow preceding trigger, all parameters were
219 significantly influenced by the addition of filters. Except for tidal volume, HME filters performed
220 significantly worse than low pressure filters. (Table 1 and Figure 5).

221
222 With NIV, the type of circuit setup had a significant impact on in flow preceding triggering ($p<0.0001$),
223 inspiratory effort to trigger the ventilator ($p<0.0001$), triggering delay ($p<0.0001$); maximal inspiratory
224 pressure ($p<0.0001$), V_t ($p:0.0008$), WOB ($p<0.0001$), PTPt ($p<0.0001$) and sPVA ($p<0.0001$) (Table 2
225 and Figure 6). Type of sPVA varied significantly between circuit setups ($p<0.0001$) (e-Table 2). Setup 5
226 using dual limb circuit was the best setup as flow preceding triggering, inspiratory effort to trigger the
227 ventilator, triggering delay, and PTPt were lower than in other setups with similar V_t delivered pressure
228 and sPVA. Setup 8 using a helmet interface had the poorest performance regarding triggering delay,
229 PTPt, inspiratory effort to trigger the ventilator and sPVA. Similar results were obtained with CPAP
230 (Table 2 and Figure 7). With CPAP, the use of setup 8 (helmet) was associated to a significant delay in
231 pressurization and the use of setup 9 (Boussignac CPAP) was associated with higher PTPt values. The
232 maximal delivered inspiratory pressure was significantly lower with the Boussignac setup pressure than
233 the one delivered by ventilators ($p<0.0001$).

234 **Discussion**

235 In this bench-study of different setups proposed for delivering NIV and CPAP during the SARS-CoV-2
236 pandemic, we have shown that modifying the circuit of a ventilator can impair ventilator triggering,
237 pressurization and performance, and affect work of breathing.

238
239 In our study, the use of a dual-limb circuit achieved the best performances. Its use was associated to
240 the lowest inspiratory effort to trigger the ventilator. Therefore, the use of ventilators that allow the use
241 of dual-limb tubing for ventilation should be preferred. Unfortunately, given the burden that the pandemic
242 has put on ventilator supplies, physicians are frequently obliged to use home non-invasive ventilators in
243 order to setup intermediate care facilities ¹⁴. Most of these ventilators can only be used with single-limb
244 circuits. In this case, the addition of intentional leaks (setups 1, 3 and 4) led to a lower maximal pressure
245 without a significant impact on the work of breathing and without increasing sPVA. With CPAP, the use
246 of active expiratory valves (setups 6 and 7) achieved better performance than setups with intentional
247 leaks.

248
249 Use of a helmet interface was associated with the worst ventilator performances in this study. This may
250 be explained by the fact that we did not change the ventilator settings. Indeed, helmet interfaces usually
251 require higher pressures than facial or nasal masks ^{16,17}. Unless the team has expertise in the use of
252 helmets ^{18,19}, we suggest limiting its use to patients who do not tolerate oro-nasal or facial masks or to
253 those for whom adequate fitting of oro-nasal or facial masks cannot be achieved ²⁰. In this situation, in
254 addition to use higher pressures, we recommend to increase the sensitivity of trigger and cycling settings
255 and to perform a close monitoring of patient-ventilator asynchronies. Indeed, in our simulations,
256 ineffective triggering and late cycling were the most common sPVA identified with the helmet setup (e-
257 Table 2).

258
259 Since the beginning of the SARS-COV2 pandemic, NIV and CPAP have been used for the management
260 of acute respiratory failure outside intensive care units ^{1,4}. In these units, physicians and healthcare
261 associated professionals may be less experienced in the delivery of acute NIV and/or CPAP which may
262 further increase the risk of nosocomial transmission⁴. In this context, in order to limit aerosol generation
263 during NIV/CPAP, we would recommend using the simplest available setup in each organization. This

264 setup may vary between centers. Indeed, this choice needs to take into account: availability of
265 ventilators, availability of additional pieces required for the setup as well as the use of prone positioning
266 outside of ICU ¹⁸. The availability of trained staff to detect and adjust ventilator settings in case of
267 asynchronies is essential to manage patients initiated on NIV or CPAP ²¹ . We believe that a trained
268 staff, when available, may overcome the limits of circuit setups identified in our bench-tests by
269 personalizing NIV or CPAP settings to patients' requirements.

270

271 With the use of single-limb circuits, we did not assess CO₂ re-breathing. However, CO₂ re-breathing is
272 proportional to the dead-space volume between the patient and the exhalation port. Therefore, the
273 exhalation port is usually placed as close as possible to the mask. Given the SARS-CoV-2 pandemic
274 and risk of droplet aerosolization, it has been suggested to connect the filter directly to the mask. Such
275 a strategy increases the dead-space volume. In setups 4 and 6, the filter was placed after the leak. This
276 may therefore limit CO₂ re-breathing with limited droplet aerosolization.

277

278 Given the lack of available ventilators during the critical phase of the pandemic, the use of a Boussignac
279 CPAP has been suggested as an alternative. In our study, the Boussignac CPAP achieved lower
280 pressures, and a lower tidal volume for a higher patient inspiratory effort than ventilator-based CPAP.
281 Because of technical limitations, we were unable to increase the flow above 30L/min: a higher flow may
282 have helped to achieve a similar pressure than ventilator-based CPAP.

283

284 The level of intentional leakage of each circuit setup may be different: this could have had an impact
285 on ventilator performance. However, in setups 2 and 3, the level of leaks was identical but, on NIV,
286 setup 3 performed better than setup 2. Hence, we hypothesize that the resistance added on the circuit
287 by the second filter is one of the main drivers of the differences seen.

288

289 Our results suggest that the use of low-pressure filters had a less deleterious impact than that of HME
290 filters. However, these results need to be interpreted with caution as we ran our tests for a limited period
291 of time and without the impact of humidification coming from air exhaled by the patient. Therefore, in a
292 non-simulated environment, humidity may increase more rapidly the resistance of low-pressure filters

293 than that of HME filters. This may lead to an increase in the work of breathing as well as a decrease in
294 the delivered pressure.

295

296 There are a few limitations of our study. Firstly, we did not assess aerosol dispersion. This would have
297 been difficult to replicate using a bench model. However, with the use of filters, the only meaningful
298 aerosol dispersion that can occur would be related to unintentional mask leaks caused by mask
299 displacement or malposition. Therefore, in addition to the use of dedicated circuit setups, clinicians
300 should carefully choose their CPAP/NIV interface whilst initiating patients with SARS-CoV2 infection on
301 a ventilator. Secondly, this is a bench-model study. We identified significant differences between setups,
302 but we were not able to assess their clinical relevance. However, assessing 8 different setups would
303 have been extremely difficult in clinical practice even using a cross-over design. Thirdly, we did not
304 assess the impact of circuit setup for each of the three lung mechanics simulated (normal, obstructive
305 and restrictive). Fourthly, we could not assess the impact of the different circuit setups on the comfort
306 of patients. As an example, setup 3 may add significant weight to the mask and this may contribute to
307 unintentional leaks, and require further tightening of the mask straps. This setup may also make prone
308 positioning of patient more difficult.

309

310 **Interpretation**

311 Ventilator performances are affected by the different circuit setups which have been proposed to
312 minimize aerosolization of viral particles during care for SARS-CoV-2 infected patients. The use of dual-
313 limb circuits should be preferred by physicians in order to maintain ventilator performance. If dual-limb
314 circuit ventilators are not available, we suggest using the single-limb setup that is the easiest to provide
315 and monitor in their institution.

316

317 **References**

- 318 1. Oranger M, Gonzalez-Bermejo J, Dacosta-Noble P, et al. Continuous positive airway pressure
319 to avoid intubation in SARS-CoV-2 pneumonia: a two-period retrospective case-control study.
320 *European Respiratory Journal* 2020;56(2).
- 321 2. Raof S, Nava S, Carpati C, Hill NS. High-Flow, Noninvasive Ventilation and Awake
322 (Nonintubation) Proning in Patients With Coronavirus Disease 2019 With Respiratory Failure.
323 *2020;158(5):1992–2002.*
- 324 3. Ahn JY, An S, Sohn Y, et al. Environmental contamination in the isolation rooms of COVID-19
325 patients with severe pneumonia requiring mechanical ventilation or high-flow oxygen therapy. *J*
326 *Hosp Infect* 2020;106(3):570–576.
- 327 4. Franco C, Facciolongo N, Tonelli R, et al. Feasibility and clinical impact of out-of-ICU
328 noninvasive respiratory support in patients with COVID-19-related pneumonia. *European*
329 *Respiratory Journal* 2020;56(5).
- 330 5. Simonds AK, Hanak A, Chatwin M, et al. Evaluation of droplet dispersion during non-invasive
331 ventilation, oxygen therapy, nebuliser treatment and chest physiotherapy in clinical practice:
332 implications for management of pandemic influenza and other airborne infections. *Health*
333 *technology assessment (Winchester, England)* 2010;14(46):131–172.
- 334 6. Leonard S, Atwood CW, Walsh BK, et al. Preliminary Findings of Control of Dispersion of
335 Aerosols and Droplets during High Velocity Nasal Insufflation Therapy Using a Simple Surgical
336 Mask: Implications for High Flow Nasal Cannula. 2020;
- 337 7. Leonard S, Strasser W, Whittle JS, et al. Reducing aerosol dispersion by High Flow Therapy in
338 COVID-19: High Resolution Computational Fluid Dynamics Simulations of Particle Behavior
339 during High Velocity Nasal Insufflation with a Simple Surgical Mask. *J Am Coll Emerg*
340 *Physicians Open* 2020;
- 341 8. Adir Y, Segol O, Kompaniets D, et al. COVID-19: minimising risk to healthcare workers during
342 aerosol-producing respiratory therapy using an innovative constant flow canopy. *European*
343 *Respiratory Journal* 2020;55(5).

- 344 9. Rabec C, Gonzalez-Bermejo J, Respiratory Support, Chronic Care Group GAVO 2 of the
345 French Society of Respiratory Diseases SPLF, GAVO 2 collaborators. Respiratory support in
346 patients with COVID-19 (outside intensive care unit). A position paper of the Respiratory
347 Support and Chronic Care Group of the French Society of Respiratory Diseases. *Respir Med*
348 *Res.* 2020;78:100768.
- 349 10. Thille AW, Rodriguez P, Cabello B, Lellouche F, Brochard L. Patient-ventilator asynchrony
350 during assisted mechanical ventilation. 2006;32(10):1515–1522.
- 351 11. Tonnelier A, Lellouche F, Bouchard PA, L'Her E. Impact of Humidification and Nebulization
352 During Expiratory Limb Protection: An Experimental Bench Study. 2013;58(8):1315–1322.
- 353 12. Gattinoni L, Coppola S, Cressoni M, Busana M, Rossi S, Chiumello D. Covid-19 Does Not
354 Lead to a “Typical” Acute Respiratory Distress Syndrome. 2020;:rccm.202003–0817LE.
- 355 13. Battisti A, Tassaux D, Janssens J-P, Michotte J-B, Jaber S, Jolliet P. Performance
356 characteristics of 10 home mechanical ventilators in pressure-support mode: a comparative
357 bench study. 2005;127(5):1784–1792.
- 358 14. Gonzalez-Bermejo J, Perrin C, Janssens JP, et al. Proposal for a systematic analysis of
359 polygraphy or polysomnography for identifying and scoring abnormal events occurring during
360 non-invasive ventilation. 2012;67(6):546–552.
- 361 15. Gonzalez-Bermejo J, Janssens J-P, Rabec C, et al. Framework for patient-ventilator
362 asynchrony during long-term non-invasive ventilation. 2019;74(7):715–717.
- 363 16. Vargas F, Thille A, Lyazidi A, Campo FR, Brochard L. Helmet with specific settings versus
364 facemask for noninvasive ventilation. 2009;37(6):1921–1928.
- 365 17. Pisani L, Mega C, Vaschetto R, et al. Oronasal mask versus helmet in acute hypercapnic
366 respiratory failure. *European Respiratory Journal* 2015;45(3):691–699.
- 367 18. Retucci M, Aliberti S, Ceruti C, et al. Prone and Lateral Positioning in Spontaneously Breathing
368 Patients With COVID-19 Pneumonia Undergoing Noninvasive Helmet CPAP Treatment. 2020;

- 369 19. Aliberti S, Radovanovic D, Billi F, et al. Helmet CPAP treatment in patients with COVID-19
370 pneumonia: a multicentre cohort study. *European Respiratory Journal* 2020;56(4).
- 371 20. Hui DS, Chow BK, Lo T, et al. Exhaled air dispersion during high-flow nasal cannula therapy
372 versus CPAP via different masks. *European Respiratory Journal* 2019;53(4).
- 373 21. Elliott MW. Non-invasive ventilation: Essential requirements and clinical skills for successful
374 practice. *Respirology* 2019;24(12):1156–1164.

375

376 **Take-home points:**

377 - Study Question: Are ventilator's performances altered by circuit setups used to limit viral
378 aerosolization of virus?

379 - Results: Circuits setups and the use of filter significantly impact the performances of ventilators
380 during non-invasive ventilation and continuous positive airway pressure.

381 - Interpretation: Modifying the circuit of a ventilator can impair ventilator triggering, pressurization
382 and performance, and affect work of breathing.

383

384 **Table 1:** Impact of filters on ventilator performance during noninvasive ventilation and continuous
 385 positive airway pressure (HME: heat and moisture exchange, *: p value < 0.05 after correction for
 386 multiple comparison when compared to no filter; °: p value < 0.05 after correction for multiple comparison
 387 when comparing low-resistance filter and HME filter)

	No filter Median [IQ] / n (%)	Low resistance filter Median [IQ] / n (%)	HME filter Median [IQ] / n (%)
Non-invasive ventilation			
Flow to trigger (L/min)	11.9 [-12.1 - 23.6]	18.6 [6.5 - 24.3]	19.6 [6.5 - 24]
Inspiratory effort (cmH ₂ O)	-4.91 [-6.95 - -3.94]	-7.43 [-10.27 - -5.64]*	-7.68 [-10.1 - -5.9]*
Time to trigger (ms)	75 [51 - 135]	153 [94 - 307]*	163 [102 - 294]*
Delivered pressure (cmH ₂ O)	16.7 [16.5 - 16.9]	15.8 [14.5 - 16.2]*	15.6 [14.1 - 16.1]*
Work of breathing (mJ)	537 [317 - 1274]	822 [714 - 1282]*	814 [712 - 1268]*
Tidal volume (ml)	598 [354 - 917]	564 [328 - 760]*	555 [310 - 721]*
Patient ventilator asynchrony	3 (3%)	9 (9%)	8 (8%)
PTPt (cmH ₂ O.s)	0.070 [0.040 - 0.130]	0.230 [0.120 - 0.280]*°	0.280 [0.140 - 0.328]*°
Continuous positive airway pressure			
Flow to trigger (L/min)	23.6 [11.5 - 36.9]	25.9 [13.3 - 35.1]	29 [13.7 - 36]
Time to trigger (ms)	220.7 [166 - 262.7]	281.3 [201.2 - 330.1]*°	294.9 [214.8 - 351.6]*°
Delivered pressure (cmH ₂ O)	8.1 [8.1 - 8.2]	7.9 [7.4 - 8]*°	7.8 [7.1 - 7.9]*°
Tidal volume (ml)	359 [196 - 559]	344 [182 - 485]*°	341 [180 - 469]*°
PTPt (cmH ₂ O.s)	0.189 [0.122 - 0.275]	0.328 [0.289 - 0.548]*°	0.382 [0.325 - 0.637]*°

388

389 **Table 2:** Impact of circuit setup on ventilator performance during noninvasive ventilation and continuous positive airway pressure (PTP: pressure time product;
 390 NA: not applicable; * : p value < 0.05 after correction for multiple comparison when compared to setup 5)

	Setup 1	Setup 2	Setup 3	Setup 4	Setup 5	Setup 6	Setup 7	Setup 8	Setup 9
	Median [IQ] / n (%)	Median [IQ] / n (%)	Median [IQ] / n (%)	Median [IQ] / n (%)	Median [IQ] / n (%)	Median [IQ] / n (%)	Median [IQ] / n (%)	Median [IQ] / n (%)	Median [IQ] / n (%)
Non-invasive ventilation									
Flow to trigger (L/min)	23.5 [6.5 - 24.7]*	24.1 [7.9 - 25.3]*	23.2 [7.2 - 24.3]*	24.3 [7.2 - 25.2]*	-11.3 [-15.4 - 7.4]	10.4 [3.7 - 20]*	14.1 [4.1 - 19]*	21.6 [20.1 - 24.7]*	NA
Inspiratory effort (cmH ₂ O)	-7.8 [-10.3 - -5.9]*	-7.7 [-10.3 - -5.8]*	-7.4 [-10.3 - -6.0]*	-7.6 [-10.4 - -6.0]*	-3.9 [-4.4 - -3.5]	-7.3 [-9.7 - -6.0]*	-7.0 [-8.8 - -5.57]*	-10.5 [-11.2 - -9.9]*	NA
Time to trigger (ms)	165 [102 - 312]*	163 [99 - 310]*	153 [104 - 307]*	158 [104 - 320]*	51 [41 - 61]	149 [105 - 266]*	135 [92 - 211]*	323 [278 - 402]*	NA
Delivered pressure (cmH ₂ O)	15.6 [14.6 - 15.7]	15.9 [15 - 16]	13.5 [13.1 - 13.9]*	13.9 [13.6 - 14.4]*	15.6 [15 - 15.9]	16.2 [16.1 - 17.5]*	16.5 [16.4 - 16.5]*	16.3 [15.5 - 16.6]*	NA
Work of breathing (mJ)	823 [717 - 1270]	809 [709 - 1281]	783 [675 - 1320]	780 [686 - 1240]	861 [747 - 1373]	872 [815 - 1046]	520 [301 - 1129]*	875 [766 - 1406]	NA
Tidal volume (ml)	563 [280 - 748]	573 [285 - 780]	535 [267 - 715]*	544 [270 - 732]	553 [325 - 776]	563 [277 - 770]	592 [331 - 949]	529 [512 - 620]	NA
Patient ventilator asynchrony	2 (2%)	6 (7%)	2 (2%)	2 (2%)	2 (2%)	37 (41%)	11 (12%)	38 (42%)	NA
PTPt (cmH ₂ O.s)	0.255 [0.140 - 0.300]*	0.270 [0.130 - 0.300]*	0.260 [0.140 - 0.290]*	0.260 [0.140 - 0.298]*	0.050 [0.040 - 0.060]	0.260 [0.165 - 0.350]*	0.170 [0.150 - 0.290]*	0.640 [0.470 - 1.255]*	NA
Continuous positive airway pressure									
Flow to trigger (L/min)	33.0 [14.3 - 36.6]	33.6 [13.7 - 37.9]	33.2 [14.6 - 37]	33.7 [13.7 - 38]	34.6 [7 - 38.3]	23.2 [8.9 - 25.6]*	23.3 [7.8 - 25.1]*	29.1 [12.2 - 35.1]	NA
Time to trigger (ms)	289.1 [210.9 - 354]	291 [207 - 356]	311.5 [226.1 - 401.4]*	301.8 [214.4 - 379.9]	293.9 [220.2 - 314.5]	194.3 [160.2 - 279.8]*	177.7 [146.5 - 276.4]*	363.3 [265.6 - 404.8]*	NA
Delivered pressure (cmH ₂ O)	7.8 [7.8 - 7.9]*	7.9 [7.9 - 7.9]*	6.8 [6.6 - 6.9]*	7.0 [6.9 - 7.1]*	8.0 [7.9 - 8.1]	7.8 [7.4 - 7.9]*	7.9 [7.8 - 8.2]*	7.9 [7.9 - 8]*	6.5 [6.5 - 6.6]*
Tidal volume (ml)	344 [181 - 474]	345 [182 - 485]*	339 [178 - 461]	340 [180 - 470]	337 [173 - 461]	352 [183 - 526]*	360 [183 - 599]*	339 [182 - 455]	320 [173 - 414]
PTPt (cmH ₂ O.s)	0.353 [0.321 - 0.599]	0.325 [0.297 - 0.552]*	0.478 [0.376 - 0.643]	0.365 [0.325 - 0.59]	0.405 [0.343 - 0.68]	0.312 [0.257 - 0.364]*	0.293 [0.219 - 0.314]*	0.380 [0.322 - 0.863]	0.860 [0.526 - 1.039]*

392 **Figure 1:** Setups evaluated in the experiments. (1) mask, filter and right-angle connector in which a
393 4mm hole has been made (courtesy of CR); (2) mask, filter and a whisper swivel exhalation valve; (3)
394 mask, T-connector, filter and whisper swivel exhalation valve; (4) mask, 3-D printed piece with a 4mm
395 leak, and bacterial filter (courtesy of MP, EF and JGB (e-Figure 2) – 3D model available here:
396 <http://www.kernelbiomedical.com/3dleak>); (5) mask, dual limb circuit with filter on the inspiratory and
397 expiratory circuits; (6) mask, active expiratory valve and bacterial filter; (7) mask, filter and active
398 expiratory valve; (8) helmet interface, bacterial filter on the inspiratory and expiratory circuits; (9)
399 Boussignac CPAP montage, bacterial filter between valve and mask.

400 **Figure 2:** Description of how ventilator performance was assessed during non-invasive ventilation. The
401 onset of pressure support allows to measure the Triggering delay, the Flow to trigger and the Pressure
402 to trigger, and to calculate the inspiratory pressure-time product (PTP_t). The Maximal delivered pressure
403 and the Tidal volume are measured from the ASL 5000 airway pressure and piston volume. The Total
404 Work of Breathing (WOB) corresponds to the checkerboard area (combination of patient and ventilatory
405 work).

406 **Figure 3:** Description of how ventilator performances were assessed during continuous positive airway
407 pressure. The onset of pressure regulation allows to measure the Regulation delay, the Flow to
408 regulation and to calculate the equivalent inspiratory pressure-time product (PTPt). The Maximal
409 delivered pressure and the Tidal volume are measured from the ASL 5000 airway pressure and piston
410 volume.

411 **Figure 4:** Ventilator performance according to the type of filter used during non-invasive ventilation
412 (HME: heat and moisture exchange, p values are reported when a significant difference after correction
413 for multiple comparison when compared to no filter)

414 **Figure 5:** Ventilator performance according to the type of filter used during continuous positive airway
415 pressure (HME: heat and moisture exchange, p values are reported when a significant difference after
416 correction for multiple comparison when compared to no filter)

417 **Figure 6:** Ventilator performances during non-invasive ventilation according to the type of circuit setup
418 used (p values are reported when a significant difference after correction for multiple comparison when
419 compared to setup 2)

420 **Figure 7:** Ventilator performances during continuous positive airway pressure according to the type of
421 circuit setup used (p value are reported when a significant difference after correction for multiple
422 comparison when compared to setup 2)
423

424 **Acknowledgements:**

425 Dr. Maxime Patout is the guarantor of the content of the manuscript, including the data and analysis.

426 The authors would like to thank Asten Santé for providing the ventilator, the filters, the masks and the
427 circuits used in this trial.

428 The authors would also like to thank Alexandre Nicol and Phoenix effect for prototyping the 3D model
429 used in setup 4 and for sharing it.

430

431 **Authors contribution:**

432 MP, EF: conception, acquisition, analysis, interpretation, drafting the work, revising critically

433 LR: acquisition, interpretation

434 JPJ, CR, AC, AK, HN, YTL, AC, JFM, CL, BL, JS, TS, JGB, ML: conception, interpretation

435 and, revising critically

436

437 **Competing Interests statement:**

438 MP reports personal fees from Resmed, Philips Respironics, grants and non-financial support from
439 Fisher & Paykel, nonfinancial support and personal fees from Asten, research grants from B&D
440 Electromedical and Fisher & Paykel, personal fees and non-financial support from Chiesi outside the
441 submitted work.

442 In the last 2 years JGB received fees from Philips, Resmed, Breas, Lowenstein and Air Liquide for
443 expertise, and a grant from BREAS for a trial, outside the submitted work.

444 JS reports advisory and teaching payments from ResMed, Philips, Chiesi and Menarini outside the
445 submitted work.

446 In the last two years, CR received fees from Philips, ResMed, Lowenstein and Fischer & Paykel for
447 expertise, outside the submitted work.

448 EF, AK, LR, AC, CL, BL, ML, AC, JFM, HN, YTL reports no competing interest

449

450

451 1.

452

Online supplement of “Recommended approaches to minimize aerosol dispersion of SARS-CoV2 during noninvasive ventilatory support can deteriorate ventilator performances: a benchmark comparative study

Maxime Patout, Emeline Fresnel, Manuel Lujan, Claudio Rabec, Annalisa Carlucci, Léa Razakamanantsoa, Adrien Kerfourn, Hilario Nunes, Yacine Tandjaoui-Lambiotte, Antoine Cuvelier, Jean-François Muir, Cristina Lalmoda, Bruno Langevin, Javier Sayas, Thomas Similowski, Jesus Gonzalez-Bermejo, Jean-Paul Janssens on behalf of the SomnoNIV group

e-Figure 1: 3D-printed head model with setup 4 test.



e-Figure 2: 3-D model of the connector used in setup 4.

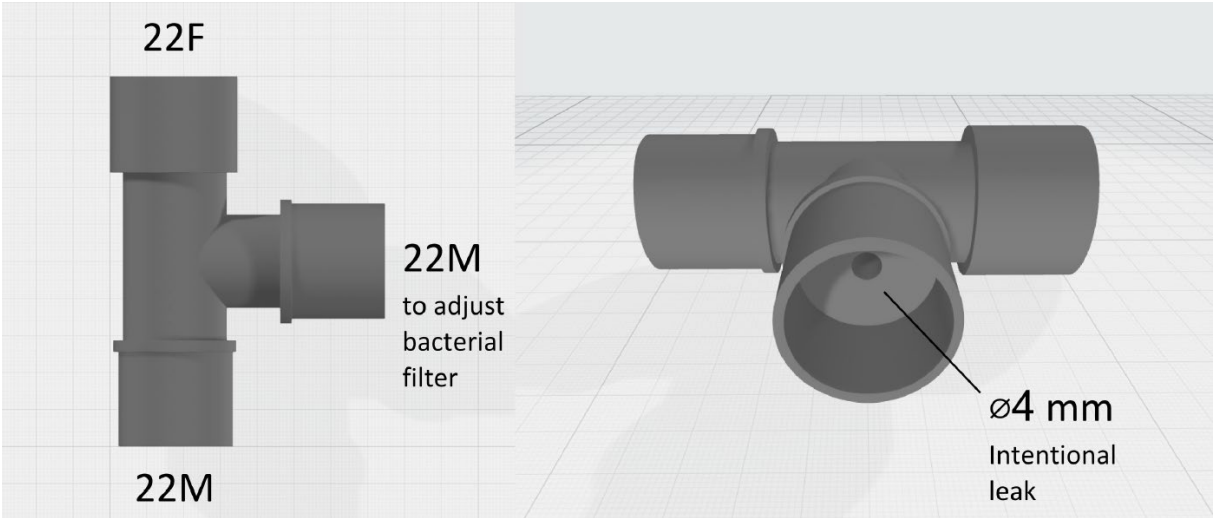

e-Figure 3: Simulated assisted breathing cycle with ASL 5000 (airway pressure, patient flow and muscular pressure). Point (b) is indicative of the sensitivity of the trigger, while keeping in mind that this value is affected, on one hand, by the intensity of the inspiratory effort and, on the other hand, by the characteristics of the patient-ventilator interface, such as the length of the circuit, its compliance, the presence of a humidifier or the type of mask. In our case, the inspiratory effort and the ventilatory settings are the same in all simulations. Therefore, the only variable for which we assessed the impact on ventilator performances is the circuit setup.

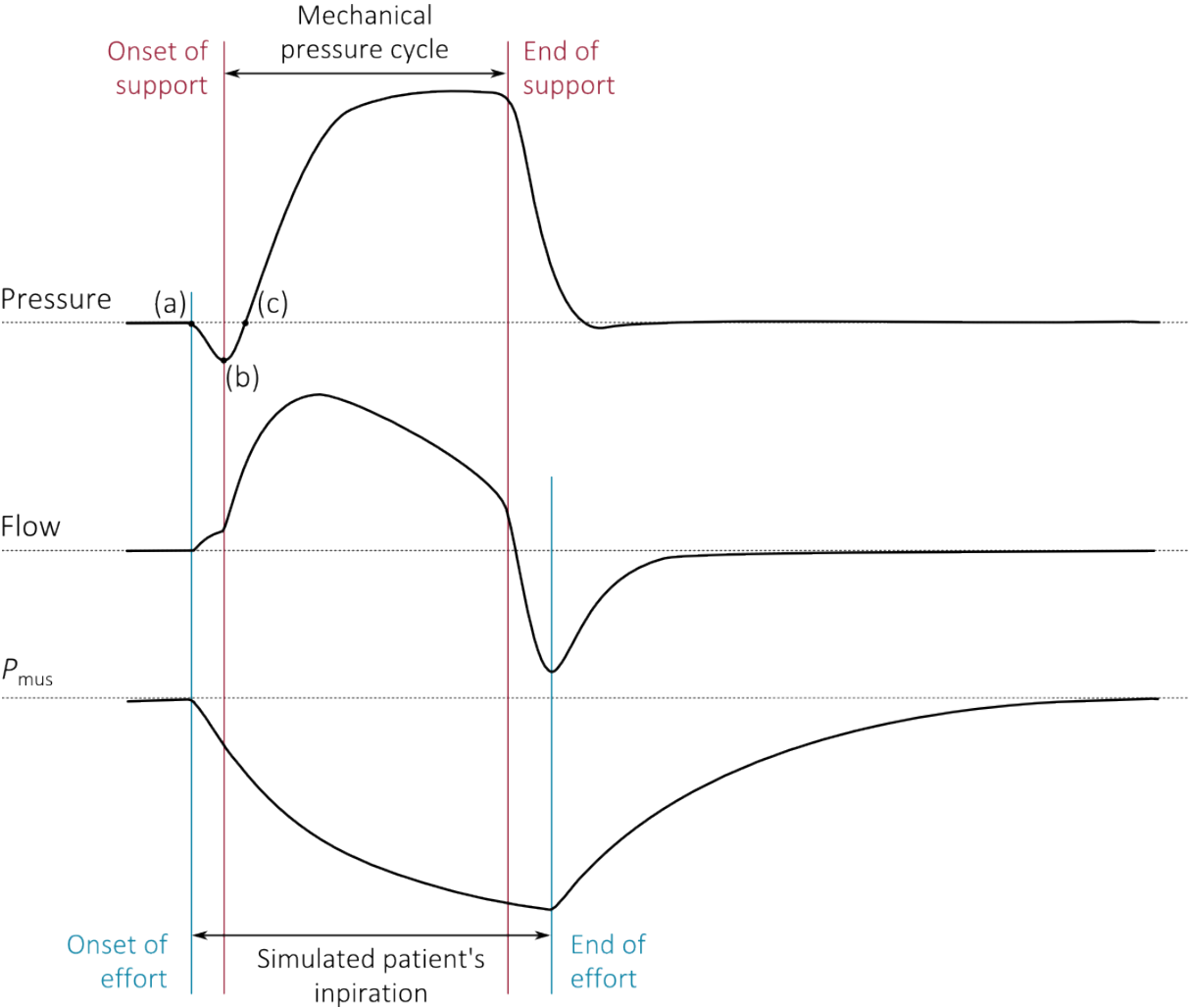

Experimental model: Circuit setups:

The dead space between the mask and the exhalation valve was*:

- Setup 1: 1 filter + 1 elbow connector (ResMed) \approx 65 ml
- Setup 2: 1 filter + 1 Whisper Swivel II (Respironics) \approx 75 ml
- Setup 3: 1 T connector (Intersurgical) + 1 filter + 1 Whisper Swivel II \approx 105 ml
- Setup 4: 1 3D connector (Phoenix effect) \approx 25 ml (3-D printed connector available here: <http://www.kernelbiomedical.com/3dleak>) (efigure 5)
- Setup 6: 1 T connector + 1 expiratory valve (Intersurgical) \approx 45 ml
- Setup 7: 1 filter + 1 expiratory valve (Intersurgical) \approx 75 ml

For setups 5 and 8, there was no additional dead space given the dual limb circuit.

* *an average volume of 50 ml was used for the filter dead space*

e-Table 1: Proportion of synchronized and asynchronized cycles during non-invasive ventilation without the use of any filter or with the use of low resistance filter (Low filter) and with heat and moisture exchange (HME). Results reported as percentage of cycles (p:0.3240)

	No filter	Low filter	HME
Ineffective efforts	1.7	2.5	2.8
Auto-triggering	0.0	1.4	1.7
Double triggering	0.0	0.0	0.0
Early cycling	1.1	0.0	0.0
Late cycling	0.0	5.0	3.3
Synchronized cycles	97.2	91.1	92.2

eTable 2: Proportion of synchronized and asynchronized cycles during non-invasive ventilation with the different type of circuit setups. Results reported as percentage of cycles (p<0.0001)

	Setup 1	Setup 2	Setup 3	Setup 4	Setup 5	Setup 6	Setup 7	Setup 8
Ineffective efforts	0.0	0.0	0.0	0.0	0.0	5.9	0.0	12.6
Auto-triggering	1.5	1.5	0.0	0.0	1.5	0.7	1.5	1.5
Double triggering	0.0	0.0	0.0	0.0	0.0	0.0	0.0	0.0
Early cycling	0.0	0.0	0.0	0.0	0.0	0.0	0.0	3.0
Late cycling	0.0	3.0	0.0	0.0	0.0	0.7	0.0	18.5
Synchronized cycles	98.5	95.6	100.0	100.0	98.5	92.6	98.5	64.4

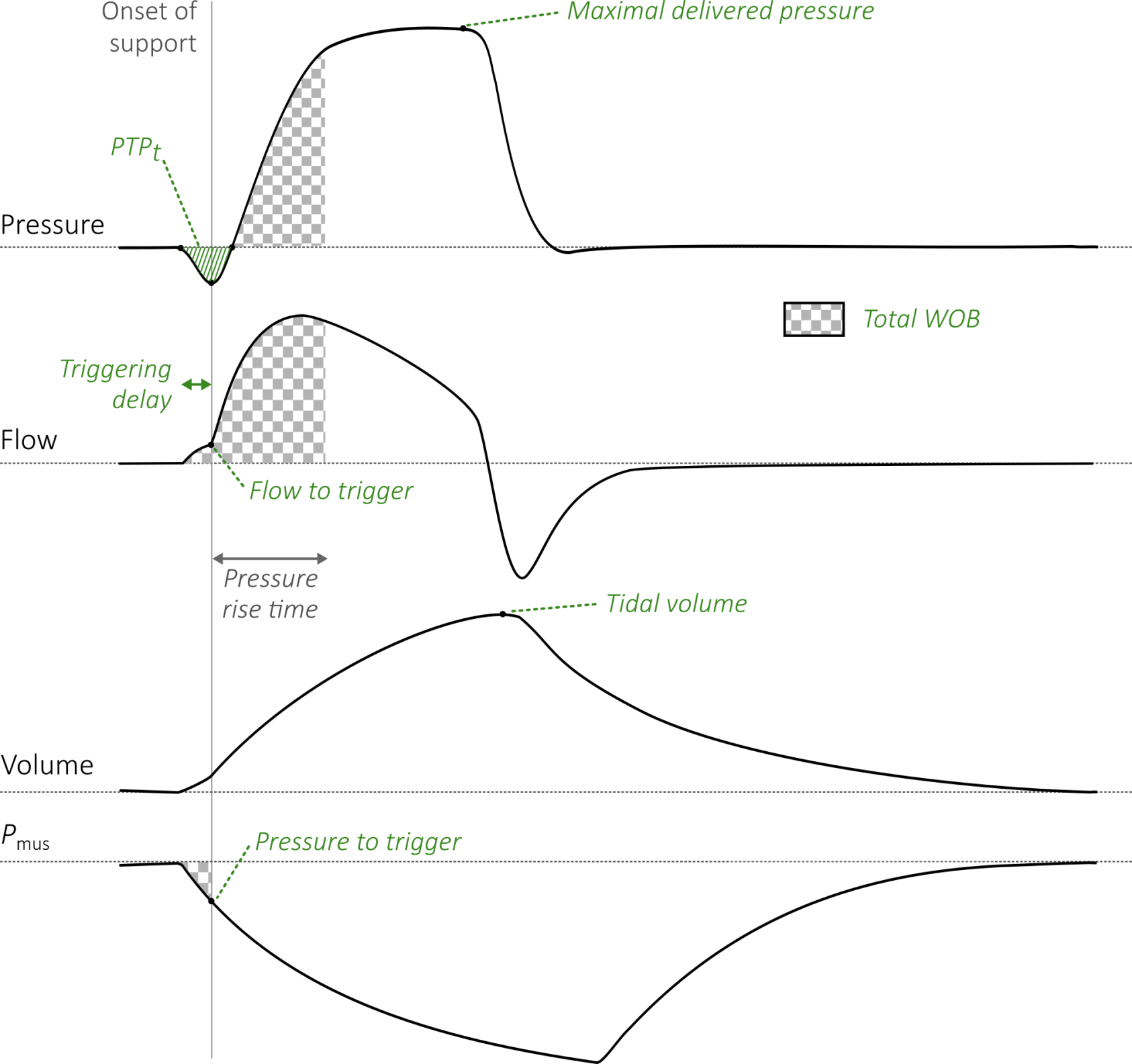

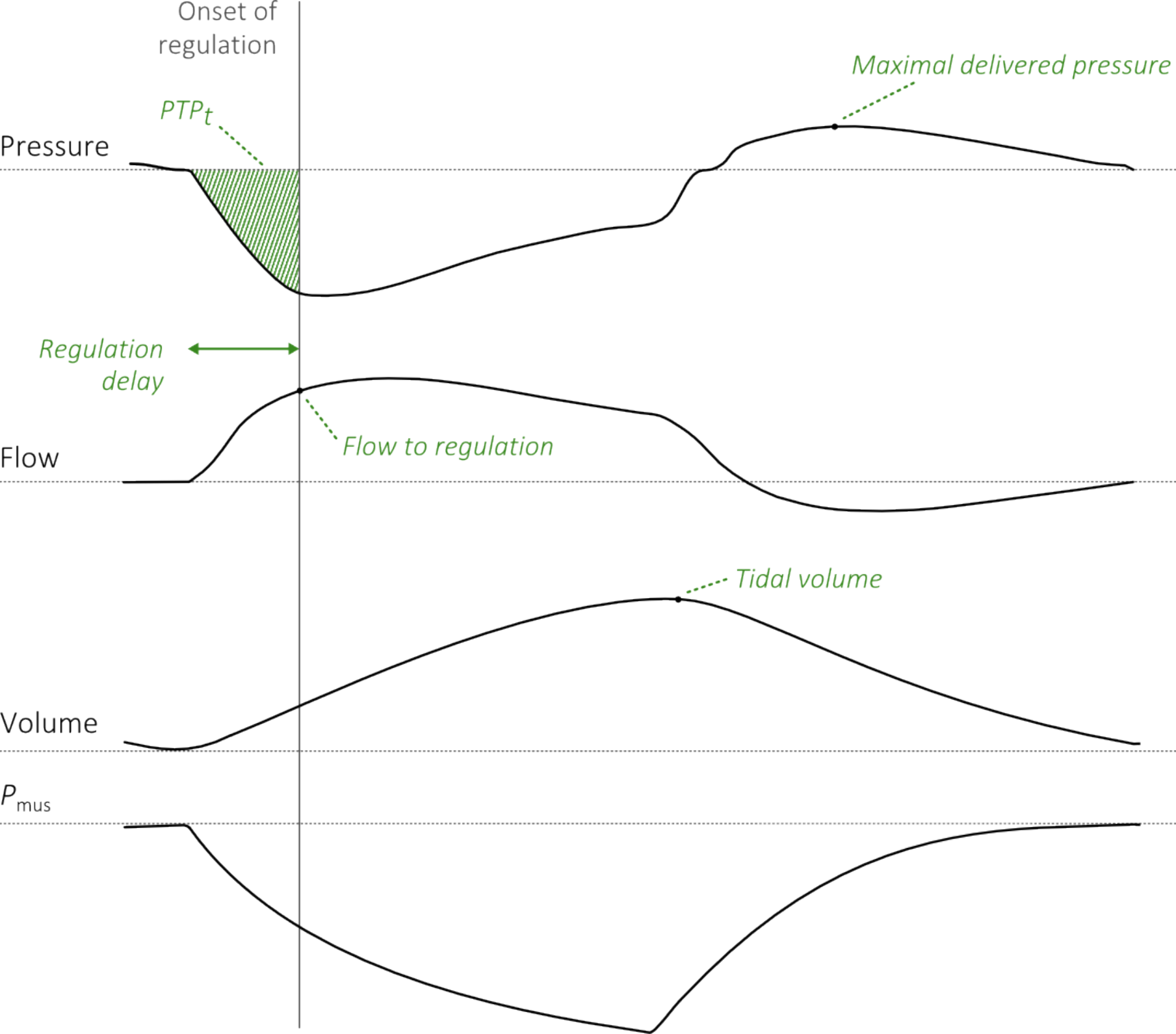

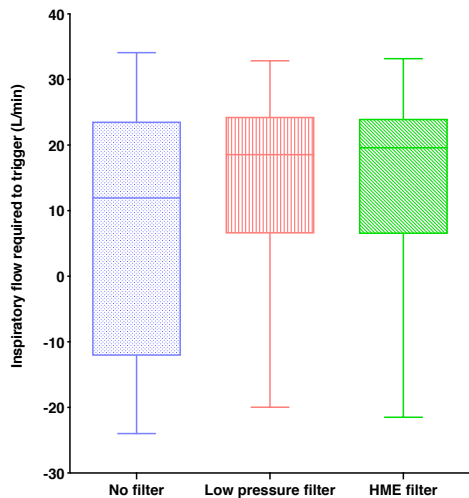
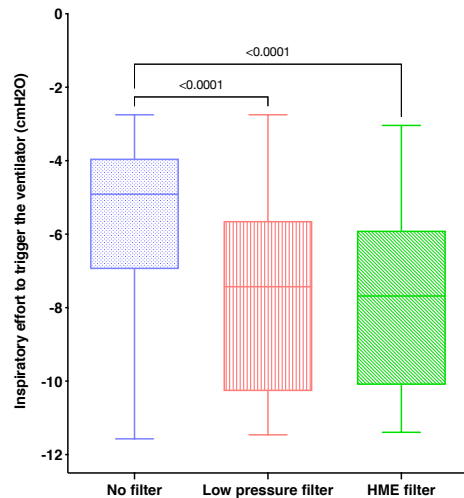
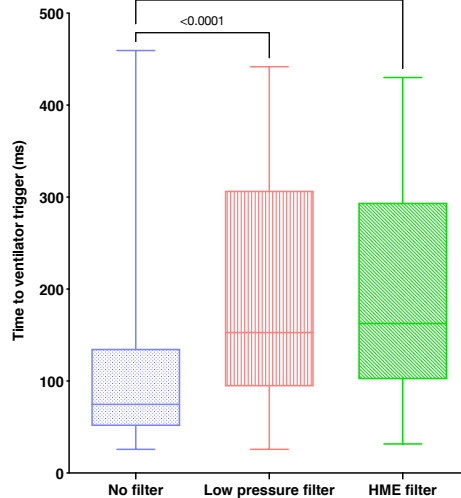
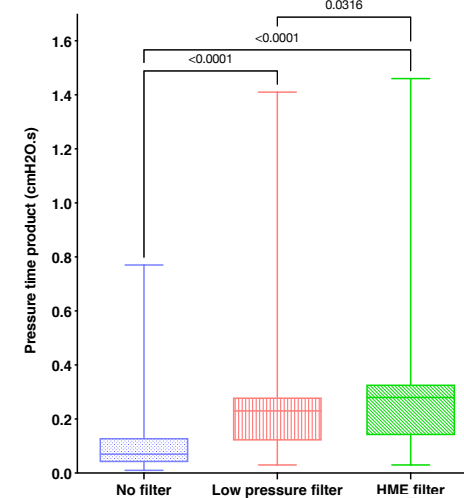
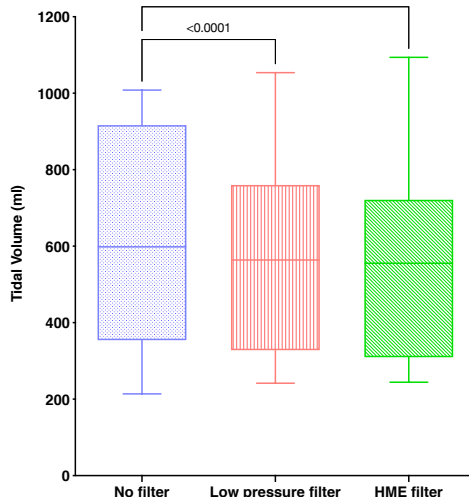
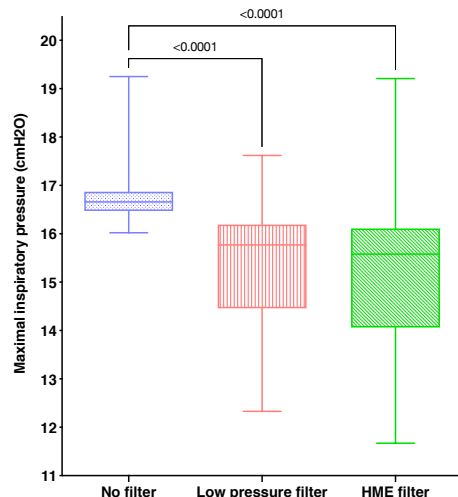
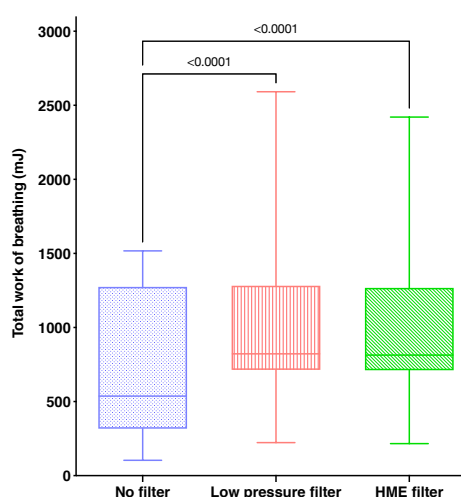
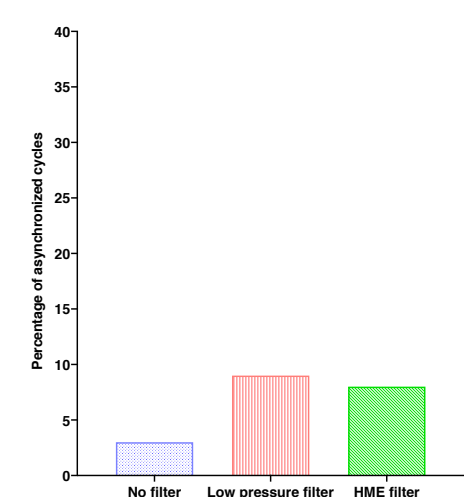
Flow preceding inspiratory trigger ($p=0.0423$)**Inspiratory effort required to trigger ($p<0.0001$)****Triggering delay ($p<0.0001$)****Pressure time product to trigger ($p<0.0001$)****Tidal volume ($p<0.0001$)****Maximal inspiratory pressure ($p<0.0001$)****Total work of breathing ($p<0.0001$)****Simulated patient-ventilator asynchrony ($p:0.190$)**

Inspiratory flow preceding ventilator response (p:0.9760)

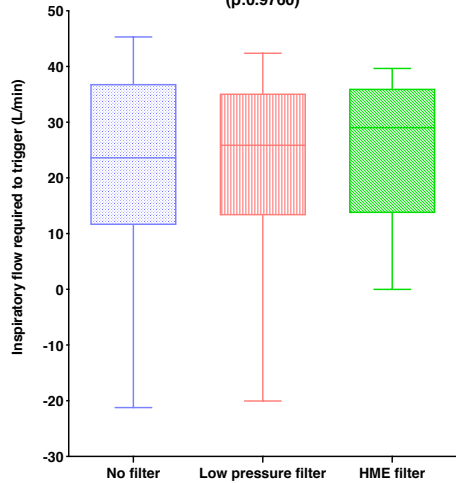

Triggering delay (p<0.0001)

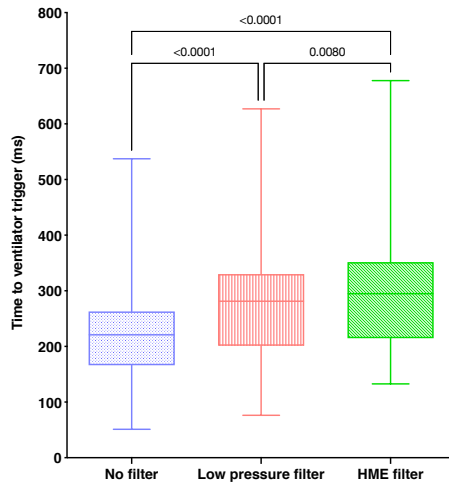

Pressure time product to ventilator response (p<0.0001)

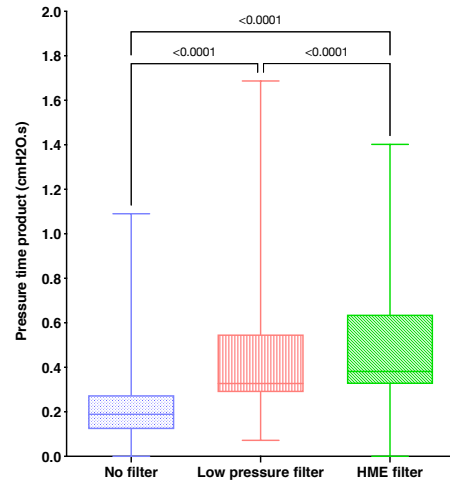

Tidal volume (p<0.0001)

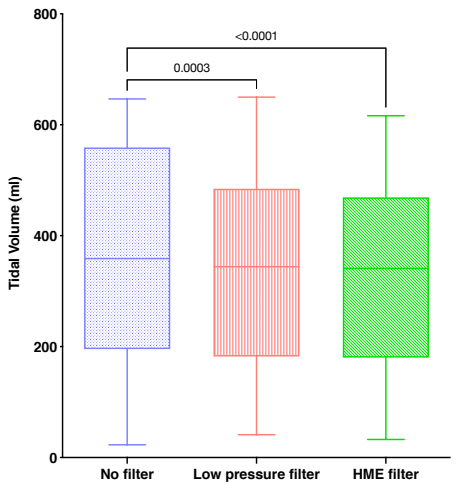

Maximal delivered pressure (p<0.0001)

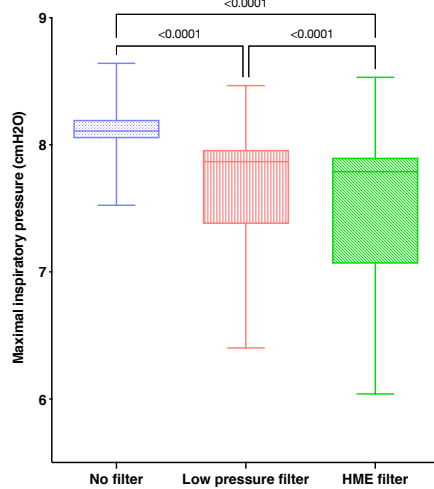

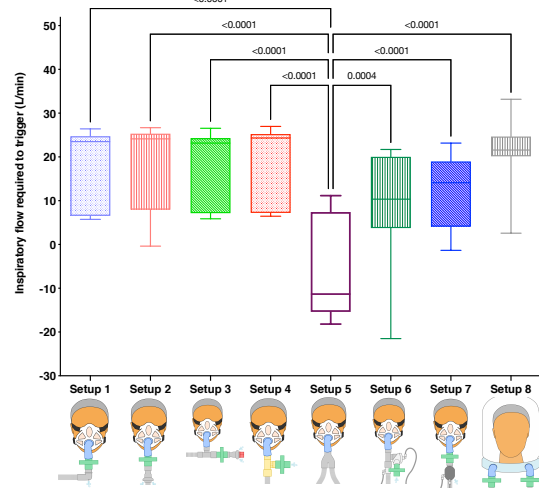
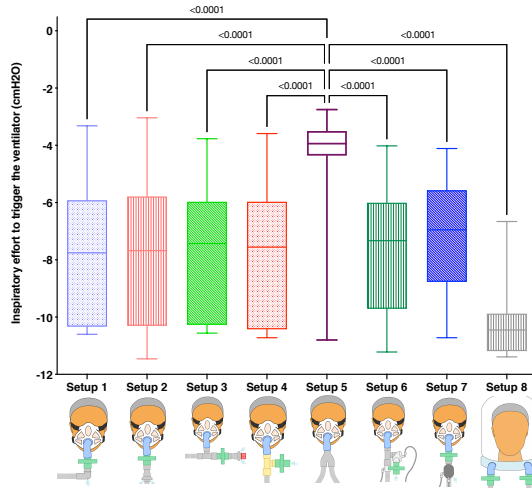
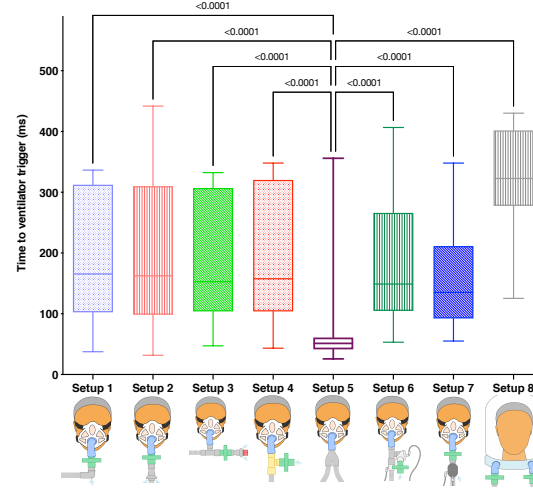
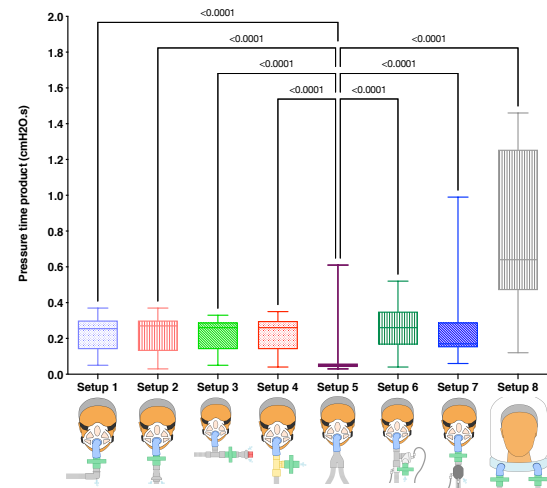
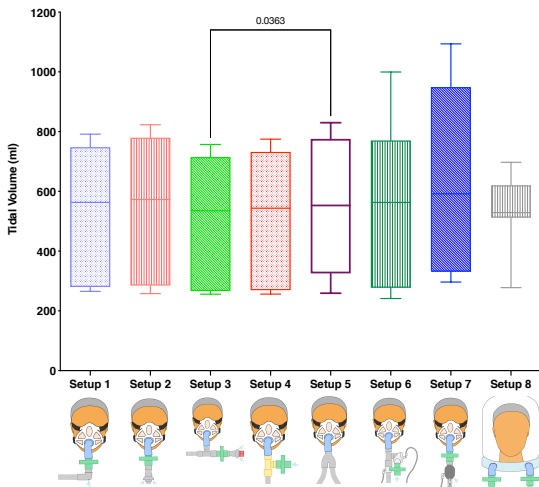
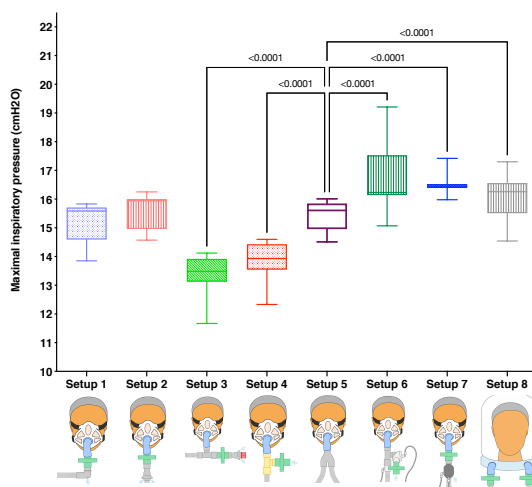
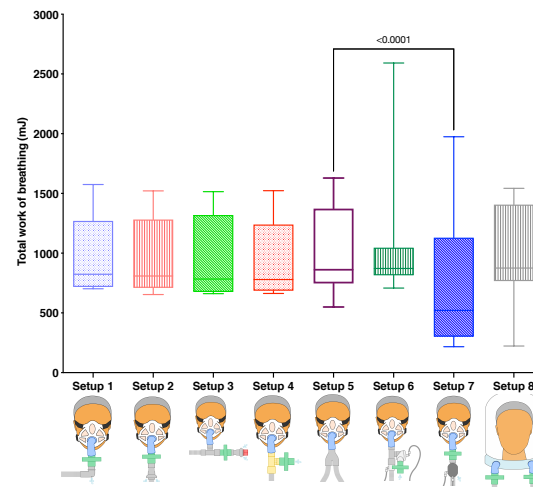
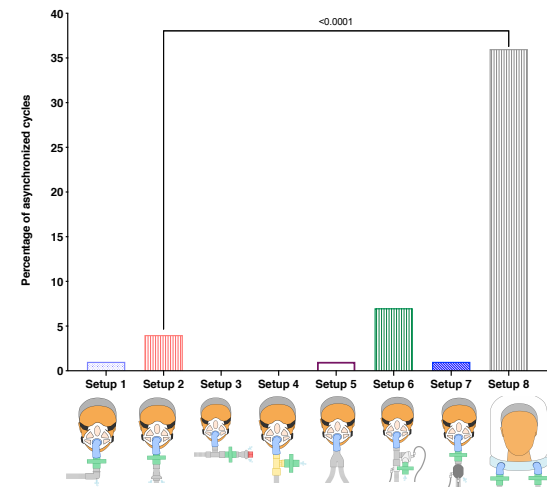
Flow preceding inspiratory trigger (p<0.0001)**Inspiratory effort required to trigger (p<0.0001)****Triggering delay (p<0.0001)****Pressure time product to trigger (p<0.0001)****Tidal volume depending on the circuit type (p=0.0008)****Maximal inspiratory pressure (p<0.0001)****Total work of breathing (p<0.0001)****Simulated patient-ventilator asynchrony (p<0.0001)**

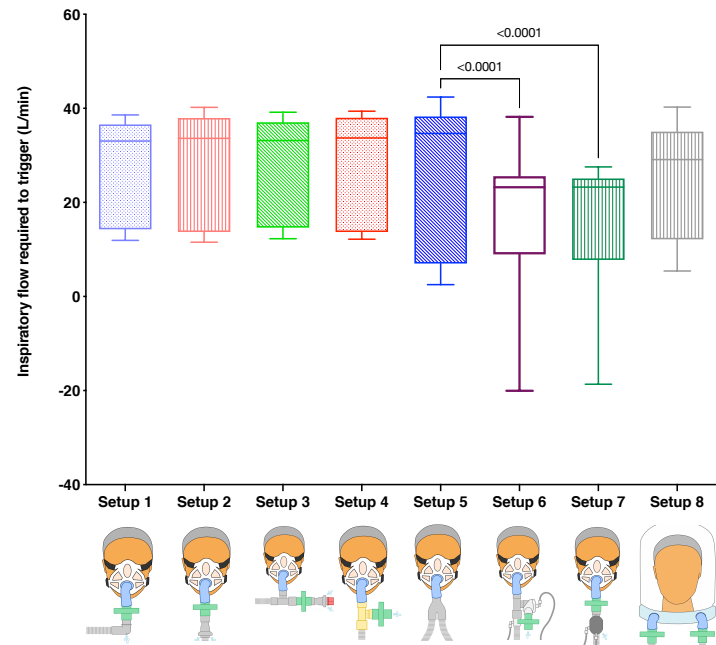
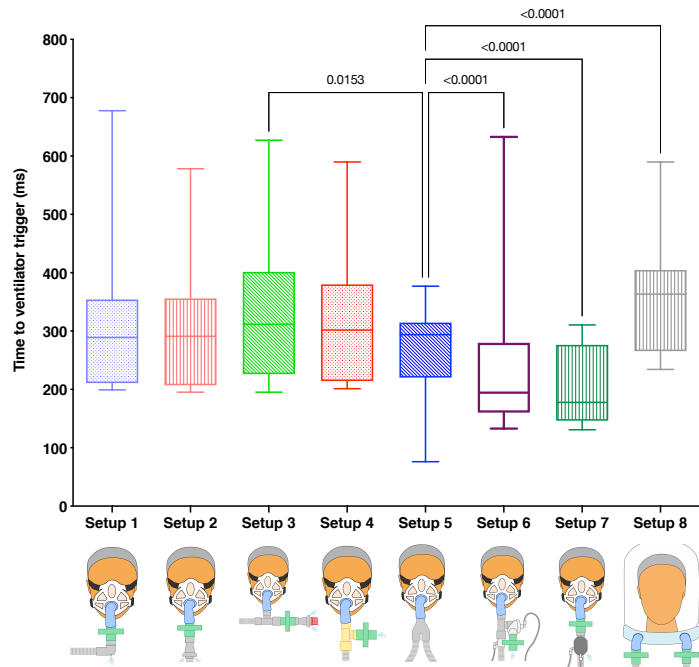
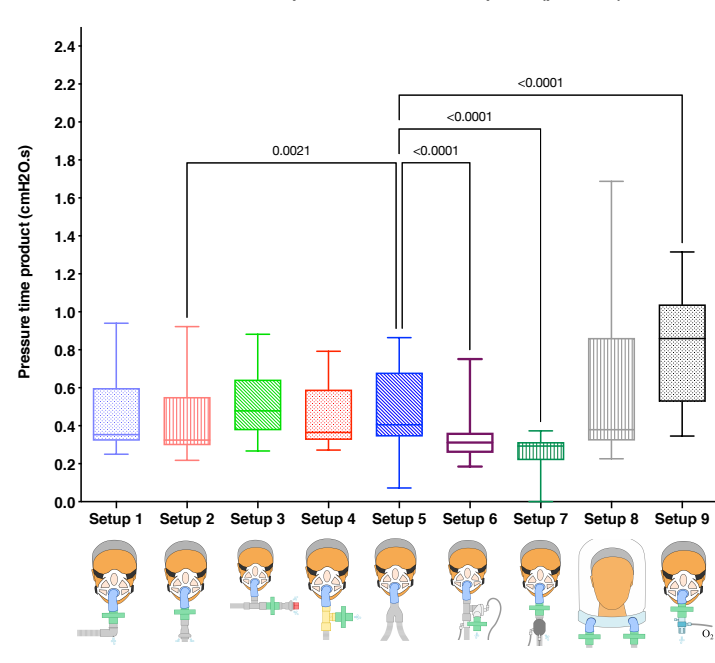
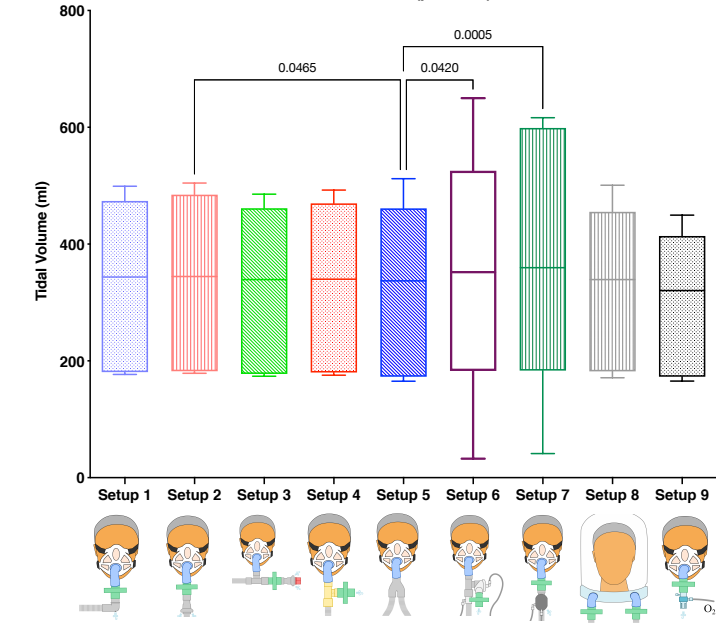
Inspiratory flow preceding ventilator response (p:0.0016)**Delay in pressurisation response (p:0.0022)****Pressure time product to ventilator response (p<0.0001)****Tidal volume (p:0.0018)****Maximal delivered pressure (p<0.0001)**