



HAL
open science

Neurophysiological basis of respiratory discomfort improvement by mandibular advancement in awake OSA patients

Rémi Valentin, Marie-Cécile Niérat, Nicolas Wattiez, Olivier Jacq, Maxens Decavèle, Isabelle Arnulf, Thomas Similowski, Valérie Attali

► To cite this version:

Rémi Valentin, Marie-Cécile Niérat, Nicolas Wattiez, Olivier Jacq, Maxens Decavèle, et al.. Neurophysiological basis of respiratory discomfort improvement by mandibular advancement in awake OSA patients. *Physiological Reports*, 2024, 10.14814/phy2.15951 . hal-04471365

HAL Id: hal-04471365



<https://hal.sorbonne-universite.fr/hal-04471365>

Submitted on 21 Feb 2024

HAL is a multi-disciplinary open access archive for the deposit and dissemination of scientific research documents, whether they are published or not. The documents may come from teaching and research institutions in France or abroad, or from public or private research centers.

L'archive ouverte pluridisciplinaire **HAL**, est destinée au dépôt et à la diffusion de documents scientifiques de niveau recherche, publiés ou non, émanant des établissements d'enseignement et de recherche français ou étrangers, des laboratoires publics ou privés.

Neurophysiological basis of respiratory discomfort improvement by mandibular advancement in awake OSA patients

Rémi Valentin^{1,2,3}  | Marie-Cécile Niérat¹ | Nicolas Wattiez¹ | Olivier Jacq¹ |
Maxens Decavèle^{1,4} | Isabelle Arnulf^{2,5} | Thomas Similowski^{1,6} | Valérie Attali^{1,2,3} 

¹INSERM, UMRS1158

Neurophysiologie Respiratoire
Expérimentale et Clinique, Sorbonne
Université, Paris, France

²Hôpital Pitié-Salpêtrière, Département
R3S, Service des Pathologies du
Sommeil (Département R3S), AP-HP,
Groupe Hospitalier Universitaire
APHP-Sorbonne Université, Paris,
France

³Institut de Biomécanique Humaine
Georges Charpak, École Nationale
Supérieure des Arts et Métiers, Paris,
France

⁴Service de Médecine Intensive et
Réanimation (Département R3S),
Groupe Hospitalier Universitaire
APHP-Sorbonne Université, Paris,
France

⁵Paris Brain Institute (ICM), Sorbonne
Université, Paris, France

⁶Hôpital, Pitié-Salpêtrière, Département
R3S, AP-HP, Groupe Hospitalier APHP-
Sorbonne Université, Paris, France

Correspondence

Rémi Valentin, Sorbonne Université,
INSERM, UMRS1158 Neurophysiologie
Respiratoire Expérimentale et Clinique,
91, bd de l'hôpital, 75013 Paris, France.
Email: remi.valentin@ensam.eu

Funding information

APHP; Institut Carnot APHP

Abstract

Patients with obstructive sleep apneas (OSA) do not complain from dyspnea during resting breathing. Placement of a mandibular advancement device (MAD) can lead to a sense of improved respiratory comfort (“pseudo-relief”) ascribed to a habituation phenomenon. To substantiate this conjecture, we hypothesized that, in non-dyspneic awake OSA patients, respiratory-related electroencephalographic figures, abnormally present during awake resting breathing, would disappear or change in parallel with MAD-associated pseudo-relief. In 20 patients, we compared natural breathing and breathing with MAD on: breathing discomfort (transitional visual analog scale, VAS-2); upper airway mechanics, assessed in terms of pressure peak/time to peak (TTP) ratio respiratory-related electroencephalography (EEG) signatures, including slow event-related preinspiratory potentials; and a between-state discrimination based on continuous connectivity evaluation. MAD improved breathing and upper airway mechanics. The 8 patients in whom the EEG between-state discrimination was considered effective exhibited higher Peak/TTP improvement and transitional VAS ratings while wearing MAD than the 12 patients where it was not. These results support the notion of habituation to abnormal respiratory-related afferents in OSA patients and fuel the causative nature of the relationship between dyspnea, respiratory-related motor cortical activity and impaired upper airway mechanics in this setting.

KEYWORDS

dyspnea, electroencephalography, neurophysiology, OSA, respiratory drive

This is an open access article under the terms of the [Creative Commons Attribution](https://creativecommons.org/licenses/by/4.0/) License, which permits use, distribution and reproduction in any medium, provided the original work is properly cited.

© 2024 The Authors. *Physiological Reports* published by Wiley Periodicals LLC on behalf of The Physiological Society and the American Physiological Society.

1 | INTRODUCTION

Patients suffering from obstructive sleep apneas (OSA) do not complain of dyspnea during awake resting breathing, notwithstanding abnormalities in upper airway mechanics representing an inspiratory load (Attali et al., 2019). Yet, despite this absence of respiratory complaints, the placement of a mandibular advancement device (MAD), known to improve upper airway mechanics (Gakwaya et al., 2014), can lead to a sense of improved respiratory comfort (Attali et al., 2019), hereafter termed “pseudo-relief”. The intensity of this sensation correlates with the degree of mechanical improvement brought about by the MAD (Attali et al., 2019). This phenomenon has been interpreted as resulting from habituation to the respiratory sensations that would typically be associated with the respiratory-related brain processing of OSA-related abnormal respiratory afferents or the corresponding compensatory mechanisms. Indeed, OSA patients have an increased drive to breathe (Mezzanotte et al., 1992; Saboisky et al., 2007; Steier et al., 2010) and exhibit a respiratory-related activation of the cerebral cortex visible under the form of slow preinspiratory potentials (PIPs) (Launois et al., 2015), two circumstances generally associated with dyspnea.

Respiratory habituation has been described experimentally (Subhan et al., 2003; Von Leupoldt et al., 2011; Wan et al., 2009) and hypothesized to proceed from down-regulation of the insular cortex (Stoeckel et al., 2015; Von Leupoldt et al., 2011) or impaired somatosensory processing (Davenport et al., 2000; Fauroux et al., 2007) as it exists in OSA patients (Donzel-Raynaud et al., 2009; Grippo et al., 2011). Demonstrating respiratory habituation in OSA patients would require showing first that a neurophysiological phenomenon usually associated with dyspnea can be evidenced in the absence of dyspnea and second that this phenomenon disappears in response to an intervention associated with “pseudo-relief”.

Based on the presence of PIPs in certain patients with OSA (Launois et al., 2015) and on the association of PIPs with dyspnea in certain clinical contexts like amyotrophic lateral sclerosis (Georges et al., 2016) or mechanical ventilation in critically ill patients (Decavèle et al., 2023; Raux et al., 2019), we hypothesized that MAD-associated respiratory “pseudo-relief” would relate with MAD-associated changes in respiratory-related cortical activity.

We assessed the electroencephalography (EEG) activity by using two techniques: (1) detection of preinspiratory activity (PIP) and (2) an EEG classifier approach that assess global connectivity changes (Grosselin et al., 2018; Hudson et al., 2016; Navarro-Sune et al., 2017). In patients under mechanical ventilation an area under the receiver operating characteristic curve (ROC) area under the curve (AUC) of 0.7 or more on the EEG classifier, was associated

with the convergent relief of dyspnea and disappearance of PIPs after optimization of ventilatory parameters (Raux et al., 2019).

2 | MATERIALS AND METHODS

2.1 | Participants

We included 20 patients (4 women, median age 58 years [49–66], a body mass index (BMI) 26 kg/m² [24–31]). Patients with a BMI \geq 35 were excluded of study. They had no history of neurological or other respiratory disorders, no intake of psychotropic medications and no previous UA surgery. All had moderate to severe OSA characterized by an apnea hypopnea index (AHI) of 32 [28–48] events/h and a score at the Epworth somnolence scale (Epworth sleepiness scale, ESS; 0–24) before treatment of 11 [9–15]. All were treated for 3 months or more by a custom-made MAD (Narval CC[®], Resmed Ltd, France) titrated by a dental specialist. The MAD treatment was considered as optimal, based on symptoms control on ESS: 6 [5–7] (reduction of 6 [3–8] $p < 0.001$) and residual AHI 6 [3–14] (reduction of 23 [16–30]; $p < 0.001$). This study was conducted after legal and ethical approval by the *Comité de Protection des Personnes Ile-de-France VI—Pitié-Salpêtrière (ID RCB: 2013-A00158-37)*. Participants received information on the purpose and procedures of this study and provided written consent to participate.

2.2 | Experimental protocol

Participants were instructed to stop their MAD treatment 10 days before this experimental evaluation. The whole experiment was done while awake. Patients were sitting down on an inclinable chair, in a 45 degrees semi-recumbent position, legs in decline position and with a cervical collar maintaining neck in neutral position. Once settled in a comfortable position, patients were instructed to score their breathing sensations on a visual analog scale (VAS) (see below).

We equipped them with a 32 electrodes EEG cap (Acticap, Brain Products, Germany) connected to an EEG preamplifier (V-Amp, Brain Products, Germany) from which the signals were digitized at 2000 Hz. Simultaneously, a nasal canula recorded ventilatory signal by differential pressure transduction (DP15 Pressure Sensor ADInstruments, NZ), digitalized at 200 Hz (Powerlab 16/30, ADInstruments, NZ).

We recorded two breathing conditions, each lasting 20 min, one without MAD (natural breathing), the second while wearing the MAD.

2.3 | Breathing discomfort

Before EEG acquisition, patients were asked to answer the trigger question “do you feel breathing discomfort (yes/no)” at rest. Independently from the answer to this trigger question they were asked to rate their breathing discomfort using two VASs under natural breathing and MAD conditions. The VAS-1 assessed breathing discomfort on a nongraduated 100 mm visual analog scale anchored by “no breathing discomfort” at the left end and “intolerable breathing discomfort” at the right end (results expressed in % scale). The VAS-2 consisted on a “transitional” evaluation of the change in breathing discomfort before and after wearing MAD, on a nongraduated 100 mm scale anchored from “extreme deterioration” at the left end to “extreme improvement” on the right end, with a middle marker to indicate “no change” (results expressed in % of middle marker to extremes with “+” sign for improvement and “-” sign for deterioration) (Attali et al., 2019).

2.4 | Breathing pattern

The breathing pattern was extracted from the nasal pressure signal and inspiratory onsets were marked using an automatic trigger, visual artifacts were rejected manually

(Figure 1a). None participant had predominant/permanent mouth breathing. The breathing mode (nasal or mouth) was monitored visually and on the nasal pressure signal; artifacts due to intermittent mouth breathing, were removed during analysis. We assessed peak pressure at inspiration (Peak) defined by local maximum of negative pressure between two inspiratory onsets and time to peak (TTP) defined by the time from inspiration onset to maximum pressure peak. Peak pressure at inspiration reflects ventilation maximum flow and should increase if UA critical closing pressure was improved by mandibular advancement. TTP as an estimation of inspiratory time should decrease with the reduction of obstruction while wearing MAD (Voskrebenezv et al., 2018). Therefore, composite parameter Peak/TTP should increase whether mandibular advancement would improve breathing signal amplitude (Peak) or slope (TTP) (Figure 1b).

2.5 | Respiratory-related cortical activity

2.5.1 | Riemannian EEG classifier

As described in details elsewhere (Grosselin et al., 2018; Hudson et al., 2016; Navarro-Sune et al., 2017), an EEG classifier based on Riemannian geometry was used to compare

(a) Experimental setup & data recording

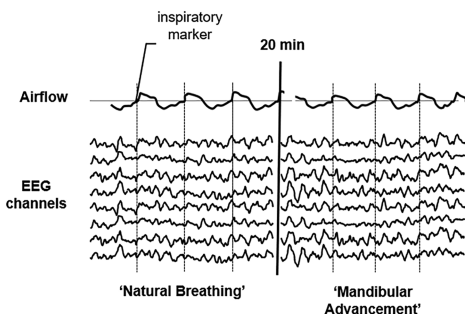
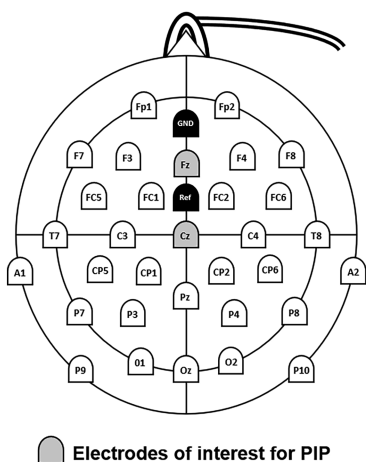

(b) Ventilatory parameters

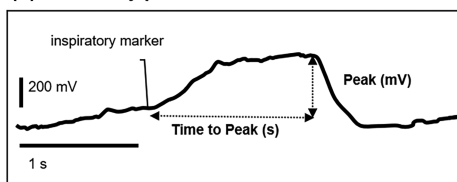

(c) EEG classifier performance

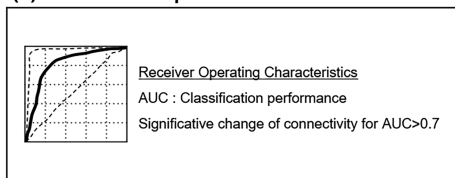

(d) Pre-inspiratory potential

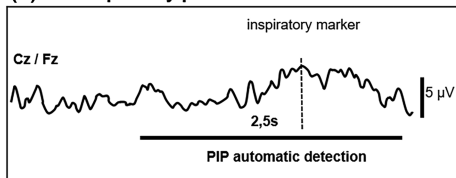

FIGURE 1 Schematic representation of the experimental setup and data analysis process. (a) Electroencephalography (EEG) was recorded using a 32 electrodes cap synchronized with nasal pressure sensor. (b) Each breathing cycle was marked at local maximum pressure amplitude (Peak) to calculate time to peak (TTP) from inspiratory onset. Peak/TTP was calculated to appreciate a modification of breathing cycle time and amplitude. (c) Modification of EEG connectivity was assessed by area under the curve (AUC) of EEG classifier based on Riemannian geometry. An AUC >0.7 was considered as significant modification of EEG activity. (d) EEG was segmented in inspiratory epochs and were averaged after artifact rejection. Algorithm detected preinspiratory potentials (PIP) within 1.5 s before inspiratory onset.

EEG recordings and estimate the performance of the classification to detect a modification in EEG signature—which is the reflection of a change in brain state—between two conditions (Grosselin et al., 2018; Hudson et al., 2016; Navarro-Sune et al., 2017; Raux et al., 2019). The classifier was first trained on natural breathing EEG matrices serving as reference to perform classification. Then the classifier compared EEG covariance matrices obtained during breathing with MAD and calculated the average deviation from the natural breathing distribution to estimate the rejection threshold indicating a significant change in cortical activity (Mason & Graham, 2002). Classification performance was evaluated by a cross-validation process: the “natural breathing” period was divided into 10 equal EEG segments and comparisons between 9 of these segments and the data of the “MAD” condition were repeated 9 times to take all combinations into account. The results were plotted as ROC curves and the prediction AUC of 1 and 0.5 indicated perfected and random discrimination, respectively (Figure 1c). An AUC ≥ 0.7 outcome was considered as satisfactory to identify a cortical activity modification (Raux et al., 2019; Taytard et al., 2022).

2.5.2 | Preinspiratory potentials

According to the method previously described inspiratory time-locked segments were averaged for both conditions (Georges et al., 2016; Launois et al., 2015; Nguyen et al., 2018; Raux et al., 2007; Tremoureux, Raux, Hudson, et al., 2014). Before data treatment, we used the inspiratory markers for EEG segmentation from -2.5 s before each inspiratory marker to 1 s after. Data was resampled to 250 Hz. We used semi-automatized artifact rejection (EEG gradient $\geq 5 \mu\text{V}/\text{ms}$; EEG amplitude $\geq 50 \mu\text{V}$) and visual validation to preprocess EEG data. An in-house computational algorithm based on time window and amplitude of EEG signal preceding inspiratory onset identified presence (PIP+) or absence (PIP-) of PIP either on Cz or Fz electrodes using Matlab (Mathworks Inc, USA) (Figure 1d). PIP+ Patients during natural breathing were retained to identify PIP modification profiles: PIP- while wearing MAD (PIP correction) and PIP+ while wearing MAD (PIP persistence).

2.6 | Statistical analysis

All statistics analyses were performed using Prism 9 © (GraphPad Software, USA). As all variables did not follow a normal distribution, the data was summarized in terms of their median and interquartile interval. Comparison of clinical features and breathing parameters between natural breathing and breathing with MAD was realized using Wilcoxon signed rank tests for paired data. Congruence

between EEG classification and PIP correction after wearing MAD was assessed by Fischer's exact test. Then, patients with an AUC ≥ 0.7 on the EEG classifier were compared to patients with an AUC < 0.7 on relative change in Peak (% of change), TTP (% change), Peak/TTP (% of change), VAS-2 (% of scale), using a Mann–Whitney test for unpaired samples. In addition, we performed a sensitivity analysis in patients exhibiting a PIP+ during natural breathing and in whom the two EEG index provided congruent results, namely either PIP disappearance when breathing with MAD associated with a Riemannian classifier AUC ≥ 0.7 or PIP persistence when wearing the MAD associated with a Riemannian classifier AUC < 0.7 . These two subgroups were compared in terms of MAD-associated changes in Peak (% of change), TTP (% change), Peak/TTP (% of change) and VAS-2 (% of scale), using a Mann–Whitney test for unpaired samples. Differences were considered statistically significant for p values below 0.05 (Figure 2).

3 | RESULTS

3.1 | Breathing discomfort

None of the participants spontaneously responded «yes» to the trigger question “do you feel breathing discomfort?” at inclusion. Nevertheless, the VAS-1 scale median score was 3 [0%–12%] during natural breathing and 0 [0%–5%] with MAD (-2 [–3.5 to 0], $p = 0.011$). The MAD-associated change in breathing comfort on the VAS-2 transitional scale was 26 [2%–56%], with 11 patients out of 20 reporting change over 20%.

3.2 | Breathing pattern

Compared to natural breathing, breathing with MAD was associated with significantly higher values of Peak amplitude (from 14 [10–28] to 17 [10–37] mV, $p = 0.002$) and Peak/TTP ratio (from 31 [15–45] to 34 [14–57] mV/s $p = 0.006$) There was no significant change in TTP (0.7 [0.6–1] to 0.8 [0.6–1] s, $p = 0.29$) or breathing frequency (14 [12–18] to 14 [11–18] cycles/min, $p = 0.43$).

3.3 | Respiratory-related cortical activity

3.3.1 | Riemannian EEG classifier

We observed a change in cortical connectivity between natural breathing and MAD conditions with a median AUC on the EEG classifier of 0.68 [0.61–0.80] and an AUC ≥ 0.7 for eight patients (40%) (Figure 3a).

(a) Result of the same patient showing change in EEG connectivity while wearing MAD

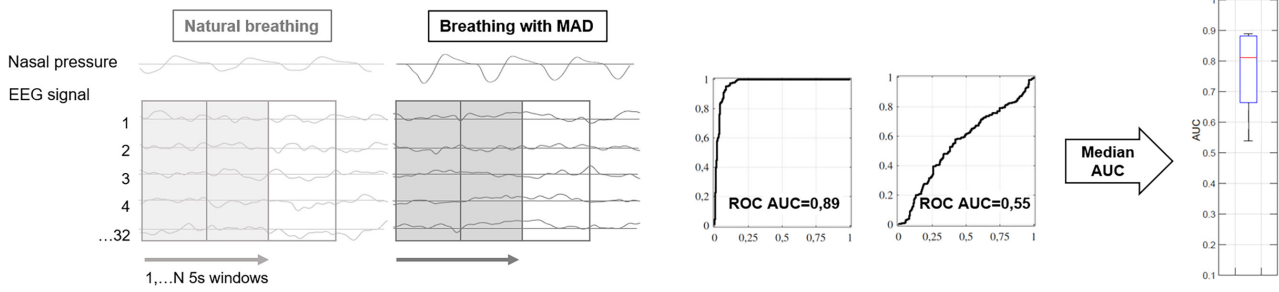

(b) Result of a patient showing PIP correction while wearing MAD

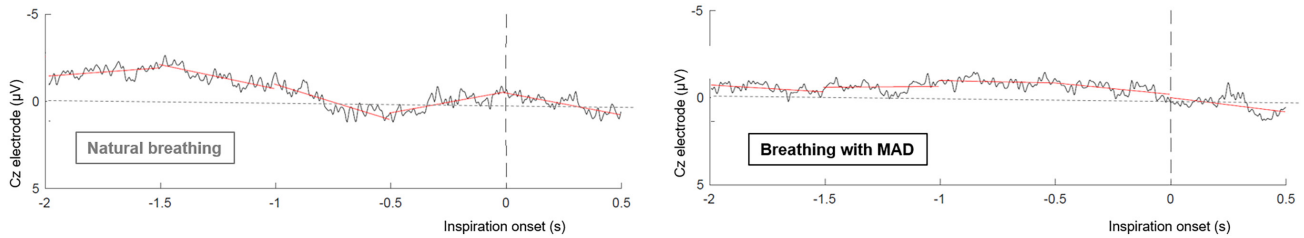

FIGURE 2 Results of one patient regarding preinspiratory potentials (PIP) detection and electroencephalography (EEG) classifier. (a) Average inspiratory epochs on Cz and Fz electrodes were divided in five windows of 0.5 s (red lines), preinspiratory activity was identified by automatic detection of amplitude and latency before inspiratory onset. During natural breathing, the presence of PIP for this patient is characterized by the slow negative shift around -0.5 s which cannot be found while breathing with mandibular advancement device (MAD). (b) On the left, covariance matrices are computed from electrode1 to 32 signals and 1 to N 5 s windows to capture the spatiotemporal dynamics of the EEG between natural breathing and breathing with MAD. In the middle, covariance matrices based on the Riemannian distance between EEG signals of both conditions was used to evaluate the ability of the classifier to detect a change in brain state using the receiver operating characteristics curve (ROC). On the right, a boxplot depicts the performance of the classifier to separate the two conditions in terms of area under the curve (AUC) (the box delineates the interquartile range of the AUC centered on median value, the whiskers correspond to the extreme values).

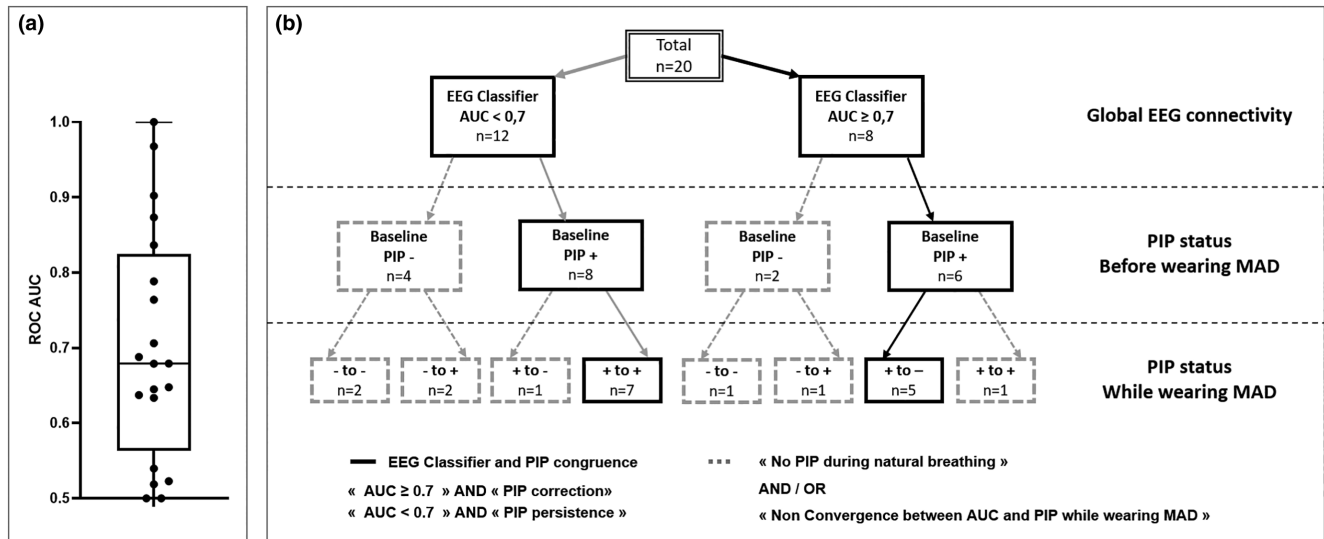

FIGURE 3 Electroencephalography (EEG) classifier area under the curve (AUC) and congruence with preinspiratory potential (PIP) between rest breathing and while wearing mandibular advancement device (MAD). (a) Boxplot centered on median with interquartile range, whiskers represent maximum and minimum values of EEG classification performance: receiver operating characteristics curve (ROC) area under the curve (AUC). An $AUC \geq 0.7$ was considered as significant for a modification of EEG activity. (b) After EEG classification ($AUC \geq 0.7$ in black and $AUC < 0.7$ in gray), considering (PIP+) presence or (PIP-) absence at baseline rest condition, we described various profiles of PIP modification while wearing MAD (-to-, -to+, +to-, +to+). Patients with baseline PIP and PIP modification congruent with EEG classification profile (« $AUC < 0.7$ /PIP+ to +» and « $AUC \geq 0.7$ /PIP+ to -» in plain line) were retained for further analysis.

3.3.2 | Preinspiratory cortical activity

Fourteen patients (70%) exhibited PIPs during natural breathing (of which six had an AUC ≥ 0.7) (Figure 3b), which disappeared when wearing MAD in six cases (P+ to -, PIP correction: of which five had an AUC ≥ 0.7) (Figure 3b) and persisted in the eight remaining cases (P+ to +, PIP persistence: of which one had an AUC ≥ 0.7) (Figure 3b). PIP modification was congruent with global connectivity (AUC < 0.7 and P+ to +; $n = 7$ OR AUC ≥ 0.7 and P+ to -; $n = 5$) for 12 of the 14 patients exhibiting PIP during normal breathing (patients in plain line on Figure 3a) ($p = 0.025$).

3.3.3 | Comparison of patients with AUC ≥ 0.7 and AUC < 0.7 on EEG classifier

Patients with AUC ≥ 0.7 ($n = 8$) and AUC < 0.7 ($n = 12$) were comparable for age (58 [52–65] vs. 60 [49–66] years, $p = 0.69$), sex ratio (2/6 vs. 2/10 female/male ratio, $p = 1$) and BMI (28 [26–31] vs. 26 [24–28] kg/m², $p = 0.38$). Patients with AUC ≥ 0.7 had higher dyspnea VAS-2 transitional score (49 [9%–75%]) than patients with AUC < 0.7 (11 [0%–35%]; $p = 0.03$). We also observed higher changes in Peak (26 [19%–41%] vs. 10 [0%–28%]; $p = 0.03$) and Peak/TTP (25 [18%–53%] vs. 3 [-12% to 14%]; $p = 0.002$) than patients with AUC < 0.7 (Figure 4).

3.3.4 | Sensitivity analysis based on PIP and EEG classifier congruence

The comparison between five patients congruently showing PIP correction while breathing with MAD and an AUC ≥ 0.7 (among the 8 AUC ≥ 0.7 patients, Figure 3b) and seven patients congruently showing PIP persistence while breathing with MAD and an AUC < 0.7 (among the 12 AUC < 0.7 patients, Figure 3b). The comparison of natural breathing and breathing when wearing the MAD showed significantly higher changes regarding Peak/TTP (20 [15%–39%] vs. -3 [-13% to 9%] change, $p = 0.005$) and dyspnea VAS-2 transitional score (72 [20%–80%] vs. 4 [0%–34%], $p = 0.034$) for the “AUC ≥ 0.7 and PIP correction” group (Figure 5).

4 | DISCUSSION

In line with our hypothesis, this study shows that patients with OSA who do not complain from dyspnea at rest and who report the largest pseudo-relief in response to mandibular advancement exhibit concomitant EEG changes similar to the changes previously reported in response to dyspnea-relieving interventions, for example after adjustments of ventilator settings in dyspneic mechanically ventilated critically ill patients (Raux et al., 2019). This provides a clear mechanistic argument in favor of

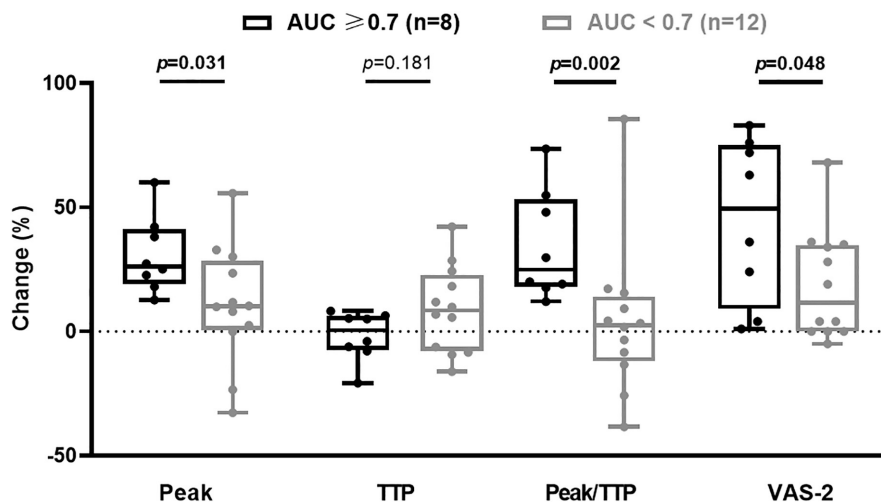

FIGURE 4 Relative change in breathing parameters while wearing mandibular advancement device (MAD) considering Electroencephalography (EEG) classifier and preinspiratory potential modification. In order to compare the ability of EEG classifier to identify patients with modification of breathing parameters while wearing MAD, we realized comparison for relative change in breathing parameters between 8 «area under the curve (AUC) ≥ 0.7 » (in black) versus 12 «AUC < 0.7 » (in gray) participants. Percentage of change (% change) was calculated as the relative difference between baseline and while wearing MAD. Peak was the average local maximum of inspiratory pressure curve; time to peak (TTP) was the average time between inspiratory onset and local maximum of inspiratory pressure curve; Peak/TTP was the ratio reflecting inspiratory amplitude of pressure and inspiratory time; VAS-2 was the score on transitional breathing discomfort scale before and after wearing MAD. Boxplot centered on median, interquartile range, whiskers represent maximum and minimum values.

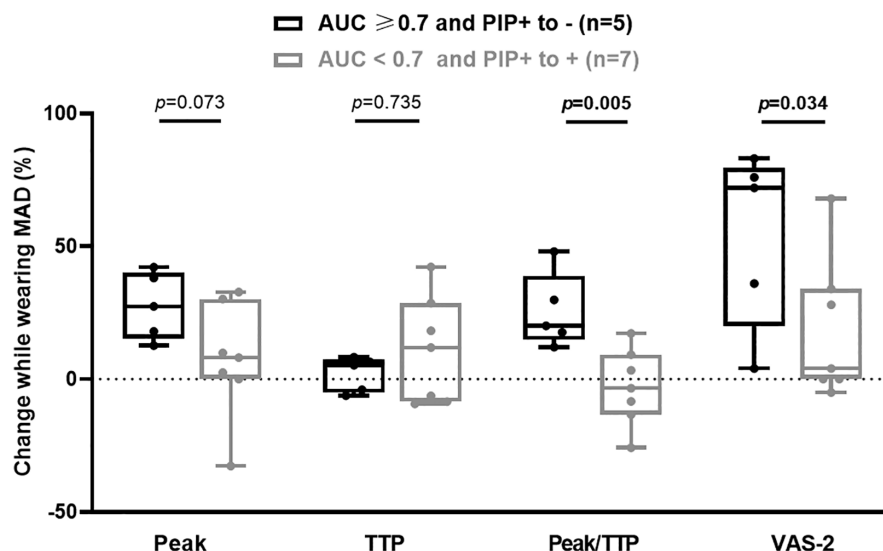

FIGURE 5 Relative change in breathing parameters while wearing mandibular advancement device (MAD) within preinspiratory potential (PIP)+ patients during rest breathing, considering electroencephalography (EEG) classifier and PIP modification. Patients exhibiting PIP during rest breathing were classified regarding both EEG classifier performance [area under the curve (AUC) ≥ 0.7] and modification of PIP while wearing MAD. In order to compare the ability of EEG classifier to identify patients with modification of breathing parameters while wearing MAD, we realized comparison for relative change in breathing parameters between 5 «AUC ≥ 0.7 /PIP+ to -» (in black) versus 7 «AUC < 0.7 and PIP+ to +» (in gray) participants. Percentage of change (% change) was calculated as the relative difference between baseline and while wearing MAD. Peak was the average local maximum of inspiratory pressure curve; time to peak (TTP) was the average time between inspiratory onset and local maximum of inspiratory pressure curve; Peak/TTP was the ratio reflecting inspiratory amplitude of pressure and inspiratory time; VAS-2 was the score on transitional breathing discomfort scale before and after wearing MAD. Boxplot centered on median, interquartile range, whiskers represent maximum and minimum values.

habituation as the explanation of the absence of dyspnea in spite of abnormal respiratory mechanics OSA patients. This is also an additional argument for the causative nature of respiratory-related EEG abnormalities in the pathogenesis of dyspnea (Decavèle et al., 2023; Georges et al., 2016; Raux et al., 2019).

4.1 | General notions about the EEG approaches used

The two EEG approaches that we used to compare the natural breathing and the MAD breathing differ in their principle. The EEG classifier based on Riemannian geometry provides a global cortical connectivity analysis (i.e. including motor, premotor, somatosensory cortical areas and deep cortical areas) without specific reference to breathing. Interpreting an EEG change detected by this technique as respiratory in origin can only result from a contextual analysis. In the present case, natural breathing and MAD breathing differed in terms of respiratory mechanics and breathing comfort, which makes it reasonable to assign the EEG connectivity changes identified to a respiratory origin. On the other hand, the PIP approach focuses on time-locked, cortical preparation of inspiration (Macefield & Gandevia, 1991). The presence

of PIPs is interpreted as bearing witness to an increased drive to breathe involving the supplementary motor area (SMA) (Raux et al., 2007) in addition to the baseline tonic activity of SMA (Laviolette et al., 2013) and the automatic control originating from the brainstem (Del Negro et al., 2018). PIPs are generally not observed in healthy subjects during natural breathing outside voluntary inspiration or speech (Tremoureux, Raux, Ranohavimparany, et al., 2014). They are therefore considered as the sign of a cortico-subcortical “cooperation” to maintain ventilation in the presence of a defective automatic breathing control (Fink, 1961), and of respiratory loading in healthy subjects (Raux et al., 2007) and in patients with respiratory disease (Georges et al., 2016; Nguyen et al., 2018; Tremoureux, Raux, Hudson, et al., 2014). The presence of PIPs, pointing at activation of the SMA, has been associated with dyspnea in certain circumstances (Georges et al., 2016; Hudson et al., 2016; Morawiec et al., 2015; Raux et al., 2019). Yet dyspnea occurs concomitantly with the activation of a much larger brain network, involving projections to the sensory cortex and integration in the limbic cortex (Farb et al., 2013) including cingulate cortex (Straus et al., 1997), posterior insula (Farb et al., 2013), and connection between posterior insula and thalamus (Farb et al., 2013). This should make the EEG classifier approach sensitive for the detection of dyspnea modulation

(Raux et al., 2019). In our patients, this is supported by the association of VAS-2 score with the EEG classifier performances.

4.2 | Significance of results

In this series, the detection of PIPs in 14 out of 20 patients confirms our previous observations in awake OSA patients (Launois et al., 2015, 2020). The presence of PIP suggests a wake-related cortical adaptation to the intrinsic load at UA level, to improve the stabilizing activity of the pharyngeal dilator muscles and prevent obstructive events (Launois et al., 2015, 2020). MAD-associated changes in PIPs and EEG classifier performances were congruent for 12 of the 14 PIP+ patients (86%) and for 15 patients in all patients (75%). In the five noncongruent patients, we observed a PIP modification in spite of an AUC <0.7 in three patients and an AUC ≥0.7 without PIP modification in two patients. PIP modification while AUC <0.7 could be explained by difference of nature between PIP analysis (amplitude analysis centered premotor cortical area and time-locked on inspiration onset) (Georges et al., 2016; Launois et al., 2015; Nguyen et al., 2018; Raux et al., 2007; Tremoureaux, Raux, Hudson, et al., 2014), and EEG classifier (covariance analysis of global connectivity) (Grosselin et al., 2018; Hudson et al., 2016; Navarro-Sune et al., 2017; Raux et al., 2019). Therefore, a modification of PIP amplitude solely located around premotor areas could be less detectable by the classifier approach than low amplitude changes occurring in several cortical areas. Similarly, AUC ≥0.7 without PIP modification can be explained by low decrease of PIP amplitude but significant change in synchrony of premotor preparation network for inspiration. PIP could thus be the “visible top” of the connectivity changes induced by MAD. For the sake of consistency, we performed a sensitivity analysis in patients in whom the two EEG approaches were congruent. We observed similar results between this conservative approach and the main analysis, namely an improvement in breathing pattern and breathing comfort in patients with AUC ≥0.7. This suggests that the EEG classifier approach alone is reliable to detect MAD-associated changes in respiratory cortical activity. Of note, those of our patients who exhibited congruent EEG changes were those in whom the largest pseudo-relief and the largest changes in respiratory pattern were observed.

4.3 | Study limitations

We have included patients treated with MAD for 3 months or more, but to avoid a potential “residual” effect of

MAD, patients were instructed to stop their MAD treatment 10 days before the evaluation. We showed a similar prevalence of PIP than in the study of Launois et al. which included non-treated patients (Launois et al., 2015). Of note, MAD is a symptomatic and not a curative treatment. Consequently, while awake when the patient is not wearing the MAD, the mechanical properties of their upper airways are not improved and this may induce a respiratory-related cortical activity in the form of a PIP. We recognize that a longitudinal evaluation of the effect of a MAD treatment on cortical activity and “pseudo-relief” constitute a perspective of this work.

We acknowledge that the absence of a control group implies a conservative interpretation of the results, however we are confident that our results support a relation between upper airway mechanics, breathing sensations and brain connectivity in patients with obstructive sleep apnea syndrome (OSAS). The present study was designed on the basis of two previous studies which had included controls. The first study showed that the prevalence of PPI was significantly higher in patients with OSAS (60% in severe OSAS and 30% in mild to moderate), than in the control group (less than 10%) ($p=0.0336$) (Launois et al., 2015). The second study showed that only patients with OSA showed an improvement in respiratory comfort when wearing a MAD while awake, and that this improvement was related to the severity of the abnormalities in upper airway mechanics. (Attali et al., 2019). We acknowledge that insufficient technical sensitivity could explain the imperfect homogeneity of our observations among patients. This could also be due to undetected phenotypic heterogeneity among the participants to our study especially regarding age which is positively related to OSAS prevalence (Bixler et al., 1998). The choice to exclude patients with a BMI superior to 35 Kg/m² was made to be consistent with previous studies (Attali et al., 2019; Launois et al., 2015). We also acknowledge that further work is needed to better characterize the brain changes associated with MAD in patients with OSA of which the EEG is only a partial reflection. For example, functional resonance imaging would be necessary to determine whether the pseudo-relief observed in our patient only proceeds from the mechanical improvement-related suppression of the compensatory cortical activation (as suggested by the experimental study of MAD in inspiratory loading by Hashimoto et al. (2006), or if it also involves the activation of the specific dyspnea-relief network described by Peiffer et al. (2008). Finally, although our study does bring a mechanistic argument for habituation as the explanation of the absence of dyspneic complaints in patients with OSA, it does not elucidate the mechanisms of this habituation. It would be interesting to confront the EEG responses to MAD to the alterations in somatosensory processing of respiratory stimuli that

exists in OSA patients (Donzel-Raynaud et al., 2009) and that could contribute to blunting respiratory sensations.

5 | CONCLUSIONS AND PERSPECTIVES

There is emerging evidence that inspiratory loading is concurrent not only with respiratory-related cortical activation, but also with impaired cognitive performances (Taytard et al., 2022). Interferences between cognition and respiratory-related cortical activity has also been described in the absence of dyspnea in patients with congenital central alveolar hypoventilation (CCAH) (Sharman et al., 2014; Taytard et al., 2023) who are known to rely on their cerebral cortex to maintain ventilation during wakefulness in spite of a defective breathing automaticity (Tremoureux, Raux, Hudson, et al., 2014). Respiratory-related cortical activation in patients with OSA could contribute to OSAS-associated impairment of cognition (Jordan et al., 2014) and of other centrally modulated functions such a balance and gait (Clavel et al., 2020; Degache et al., 2016). In the present study not only do we confirm that respiratory-related cortical activity is a reality in OSA patients, but we also show that this activity can be suppressed by as simple a mean as MAD. Therefore, our study justifies to assess the immediate cognitive effects of MAD (or any other means to suppress respiratory-related cortical activity) in OSA, in addition to the more classically studied cognitive effects of the long-term treatment of OSA.

AUTHOR CONTRIBUTIONS

RV, MCN, OJ, MD and VA contributed to design and conception of the work, acquisition, analysis or interpretation of data, NW, IA and TS contributed to design of the work, analysis and interpretation of the data. All authors contributed to drafting and revisiting of the manuscript. All authors approved final version of the manuscript and all persons who qualify as author are listed.

ACKNOWLEDGMENTS

The authors are grateful to Dr Jean Baptiste Kerbrat, Dr Deborah Fellous, Dr David Clerigues-Bosch, member of AP-HP, Groupe Hospitalier Universitaire APHP-Sorbonne Université, Hôpital Pitié-Salpêtrière, Service de Stomatologie et Chirurgie maxilla-Faciale for the help with patient recruitment.

FUNDING INFORMATION

VA is the recipient of a grant “poste d’accueil APHP/Arts et Métiers ParisTech”, Délégation à la Recherche Clinique et à l’Innovation (DRCI), Assistance Publique Hôpitaux de

Paris (APHP). RV was supported by a grant « Inter Carnot », Institut Carnot for his PhD doctorate.

CONFLICT OF INTEREST STATEMENT

RV, MCN, NW, OJ declared no link of interest. MD reported no link of interest related to the study. Outside the submitted work he reported congress registration fees from ISIS Medical. IA, reported no link of interest related to the study. Outside the submitted work she took part in an advisory board of IDORSIA in 2020. TS reported no link of interest related to the study. Outside the submitted work he reported personal fees for consulting and teaching activities from ADEP Assistance, AstraZeneca France, Chiesi France, KPL consulting, Lungpacer Inc., OSO-AI, TEVA France, Vitalaire, all outside the submitted work. VA had no link of interest related to the study. Outside the study, she took part in an advisory board of BIOPROJET in 2021.

DATA AVAILABILITY STATEMENT

All original data from which graphical and/or tabular summary data is generated is archived and fully available to The Journal upon reasonable request.

ETHICS STATEMENT

This study was conducted after legal and ethical approval by the Comité de Protection des Personnes Ile-de-France VI – Pitié-Salpêtrière (ID RCB: 2013-A00158-37). All methods were conducted in strict adherence to the relevant guidelines and the Code of Ethics of the World Medical Association (Declaration of Helsinki). Prior to participation, the study subjects provided written informed consent.

ORCID

Rémi Valentin  <https://orcid.org/0000-0001-8192-6048>

Valérie Attali  <https://orcid.org/0000-0001-5444-9223>

REFERENCES

- Attali, V., Collet, J.-M., Jacq, O., Souchet, S., Arnulf, I., Rivals, I., Kerbrat, J.-B., Goudot, P., Morelot-Panzini, C., & Similowski, T. (2019). Mandibular advancement reveals long-term suppression of breathing discomfort in patients with obstructive sleep apnea syndrome. *Respiratory Physiology & Neurobiology*, 263, 47–54.
- Bixler, E. O., Vgontzas, A. N., Ten Have, T., Tyson, K., & Kales, A. (1998). Effects of age on sleep apnea in men: I. Prevalence and severity. *American Journal of Respiratory and Critical Care Medicine*, 157, 144–148.
- Clavel, L., Rémy-Neris, S., Skalli, W., Rouch, P., Lespert, Y., Similowski, T., Sandoz, B., & Attali, V. (2020). Cervical spine hyperextension and altered Posturo-respiratory coupling in patients with obstructive sleep apnea syndrome. *Frontiers in Medicine*, 7, 30. <https://doi.org/10.3389/fmed.2020.00030>

- Davenport, P. W., Cruz, M., Stecenko, A. A., & Kifle, Y. (2000). Respiratory-related evoked potentials in children with life-threatening asthma. *American Journal of Respiratory and Critical Care Medicine*, *161*, 1830–1835.
- Decavèle, M., Bureau, C., Champion, S., Nierat, M.-C., Rivals, I., Wattiez, N., Faure, M., Mayaux, J., Morawiec, E., Raux, M., Similowski, T., & Demoule, A. (2023). Interventions relieving dyspnea in intubated patients show responsiveness of the mechanical ventilation-respiratory distress observation scale. *American Journal of Respiratory and Critical Care Medicine*, *208*, 39–48.
- Degache, F., Goy, Y., Vat, S., Haba Rubio, J., Contal, O., & Heinzer, R. (2016). Sleep-disordered breathing and daytime postural stability. *Thorax*, *71*, 543–548.
- Del Negro, C. A., Funk, G. D., & Feldman, J. L. (2018). Breathing matters. *Nature Reviews. Neuroscience*, *19*, 351–367.
- Donzel-Raynaud, C., Redolfi, S., Arnulf, I., Similowski, T., & Straus, C. (2009). Abnormal respiratory-related evoked potentials in untreated awake patients with severe obstructive sleep apnoea syndrome. *Clinical Physiology and Functional Imaging*, *29*, 10–17.
- Farb, N. A. S., Segal, Z. V., & Anderson, A. K. (2013). Mindfulness meditation training alters cortical representations of interoceptive attention. *Social Cognitive and Affective Neuroscience*, *8*, 15–26.
- Fauroux, B., Renault, F., Boelle, P. Y., Donzel-Raynaud, C., Nicot, F., Clément, A., Straus, C., & Similowski, T. (2007). Impaired cortical processing of inspiratory loads in children with chronic respiratory defects. *Respiratory Research*, *8*, 61.
- Fink, B. R. (1961). Influence of cerebral activity in wakefulness on regulation of breathing. *Journal of Applied Physiology*, *16*, 15–20.
- Gakwaya, S., Melo-Silva, C. A., Borel, J.-C., Rousseau, E., Masse, J.-F., & Sériès, F. (2014). Impact of stepwise mandibular advancement on upper airway mechanics in obstructive sleep apnea using phrenic nerve magnetic stimulation. *Respiratory Physiology & Neurobiology*, *190*, 131–136.
- Georges, M., Morawiec, E., Raux, M., Gonzalez-Bermejo, J., Pradat, P.-F., Similowski, T., & Morélot-Panzini, C. (2016). Cortical drive to breathe in amyotrophic lateral sclerosis: A dyspnoea-worsening defence? *The European Respiratory Journal*, *47*, 1818–1828.
- Grippo, A., Carrai, R., Romagnoli, I., Pinto, F., Fanfulla, F., & Sanna, A. (2011). Blunted respiratory-related evoked potential in awake obstructive sleep apnoea subjects: A NEP technique study. *Clinical Neurophysiology*, *122*, 1562–1568.
- Grosselin, F., Navarro-Sune, X., Raux, M., Similowski, T., & Chavez, M. (2018). CARE-rCortex: A Matlab toolbox for the analysis of CARDIO-RESPIRATORY-related activity in the cortex. *Journal of Neuroscience Methods*, *308*, 309–316.
- Hashimoto, K., Ono, T., Honda, E., Maeda, K., Shinagawa, H., Tsuiki, S., Hiyama, S., Kurabayashi, T., & Ohyama, K. (2006). Effects of mandibular advancement on brain activation during inspiratory loading in healthy subjects: A functional magnetic resonance imaging study. *Journal of Applied Physiology (Bethesda, Md. 1985)*, *1985*(100), 579–586.
- Hudson, A. L., Navarro-Sune, X., Martinerie, J., Pouget, P., Raux, M., Chavez, M., & Similowski, T. (2016). Electroencephalographic detection of respiratory-related cortical activity in humans: From event-related approaches to continuous connectivity evaluation. *Journal of Neurophysiology*, *115*, 2214–2223.
- Jordan, A. S., McSharry, D. G., & Malhotra, A. (2014). Adult obstructive sleep apnoea. *The Lancet*, *383*, 736–747.
- Launois, C., Attali, V., Georges, M., Raux, M., Morawiec, E., Rivals, I., Arnulf, I., & Similowski, T. (2015). Cortical drive to breathe during wakefulness in patients with obstructive sleep apnea syndrome. *Sleep*, *38*, 1743–1749.
- Launois, C., Nierat, M.-C., Attali, V., Raux, M., Arnulf, I., Similowski, T., & Redolfi, S. (2020). Postural preinspiratory cortical activity, genioglossus activity and fluid shift in awake obstructive sleep apnoea patients. *Experimental Physiology*, *105*, 370–378.
- Lavolette, L., Niérat, M.-C., Hudson, A. L., Raux, M., Allard, É., & Similowski, T. (2013). The supplementary motor area exerts a tonic excitatory influence on corticospinal projections to phrenic Motoneurons in awake humans ed. *PLoS One*, *8*, e62258.
- Macefield, G., & Gandevia, S. C. (1991). The cortical drive to human respiratory muscles in the awake state assessed by premotor cerebral potentials. *The Journal of Physiology*, *439*, 545–558.
- Mason, S. J., & Graham, N. E. (2002). Areas beneath the relative operating characteristics (ROC) and relative operating levels (ROL) curves: Statistical significance and interpretation. *Quarterly Journal of the Royal Meteorological Society*, *128*, 2145–2166.
- Mezzanotte, W. S., Tangel, D. J., & White, D. P. (1992). Waking genioglossal electromyogram in sleep apnea patients versus normal controls (a neuromuscular compensatory mechanism). *The Journal of Clinical Investigation*, *89*, 1571–1579.
- Morawiec, E., Raux, M., Kindler, F., Lavolette, L., & Similowski, T. (2015). Expiratory load compensation is associated with electroencephalographic premotor potentials in humans. *Journal of applied physiology (Bethesda, Md. 1985)*, *1985*(118), 1023–1030.
- Navarro-Sune, X., Hudson, A. L., Fallani, F. D. V., Martinerie, J., Witon, A., Pouget, P., Raux, M., Similowski, T., & Chavez, M. (2017). Riemannian geometry applied to detection of respiratory states from EEG signals: The basis for a brain-ventilator Interface. *IEEE Transactions on Biomedical Engineering*, *64*, 1138–1148.
- Nguyen, D. A. T., Boswell-Ruys, C. L., McBain, R. A., Eckert, D. J., Gandevia, S. C., Butler, J. E., & Hudson, A. L. (2018). Inspiratory pre-motor potentials during quiet breathing in ageing and chronic obstructive pulmonary disease. *The Journal of Physiology*, *596*, 6173–6189.
- Peiffer, C., Costes, N., Hervé, P., & Garcia-Larrea, L. (2008). Relief of dyspnea involves a characteristic brain activation and a specific quality of sensation. *American Journal of Respiratory and Critical Care Medicine*, *177*, 440–449.
- Raux, M., Navarro-Sune, X., Wattiez, N., Kindler, F., Le Corre, M., Decavele, M., Demiri, S., Demoule, A., Chavez, M., & Similowski, T. (2019). Adjusting ventilator settings to relieve dyspnoea modifies brain activity in critically ill patients: An electroencephalogram pilot study. *Scientific Reports*, *9*, 16572.
- Raux, M., Straus, C., Redolfi, S., Morelot-Panzini, C., Couturier, A., Hug, F., & Similowski, T. (2007). Electroencephalographic evidence for pre-motor cortex activation during inspiratory loading in humans. *The Journal of Physiology*, *578*, 569–578.
- Saboisky, J. P., Butler, J. E., McKenzie, D. K., Gorman, R. B., Trinder, J. A., White, D. P., & Gandevia, S. C. (2007). Neural drive to human genioglossus in obstructive sleep apnoea: Genioglossus motor unit behaviour. *The Journal of Physiology*, *585*, 135–146.
- Sharman, M., Gallea, C., Lehongre, K., Galanaud, D., Nicolas, N., Similowski, T., Cohen, L., Straus, C., & Naccache, L. (2014). The

- cerebral cost of breathing: An fMRI case-study in congenital central hypoventilation syndrome. *PLoS One*, 9, e107850.
- Steier, J., Jolley, C. J., Seymour, J., Ward, K., Luo, Y. M., Polkey, M. I., & Moxham, J. (2010). Increased load on the respiratory muscles in obstructive sleep apnea. *Respiratory Physiology & Neurobiology*, 171, 54–60.
- Stoeckel, M. C., Esser, R. W., Gamer, M., Büchel, C., & von Leupoldt, A. (2015). Brain mechanisms of short-term habituation and sensitization toward dyspnea. *Frontiers in Psychology*, 6, 748.
- Straus, C., Zelter, M., Derenne, J. P., Pidoux, B., Willer, J. C., & Similowski, T. (1997). Putative projection of phrenic afferents to the limbic cortex in humans studied with cerebral-evoked potentials. *Journal of Applied Physiology (Bethesda, Md. 1985)*, 1985(82), 480–490.
- Subhan, M. M. F., Butler, T. J., & Reed, J. W. (2003). Effect of repetitive exercise testing on breathlessness in humans. *Clinical science (London, England: 1979)*, 1979(105), 243–250.
- Taytard, J., Gand, C., Niérat, M.-C., Barthes, R., Lavault, S., Adler, D., Morélot-Panzini, C., Gatignol, P., Champion, S., Serresse, L., Wattiez, N., Straus, C., & Similowski, T. (2022). Impact of inspiratory threshold loading on brain activity and cognitive performances in healthy humans. *Journal of Applied Physiology (Bethesda, Md. 1985)*, 1985(132), 95–105.
- Taytard, J., Niérat, M.-C., Gand, C., Lavault, S., Morélot-Panzini, C., Patout, M., Serresse, L., Wattiez, N., Bodineau, L., Straus, C., & Similowski, T. (2023). Short-term cognitive loading deteriorates breathing pattern and gas exchange in adult patients with congenital central hypoventilation syndrome. *ERJ Open Research*, 9, 408–2022.
- Tremoureaux, L., Raux, M., Hudson, A. L., Ranohavimparany, A., Straus, C., & Similowski, T. (2014). Does the supplementary motor area keep patients with Ondine's curse syndrome breathing while awake? *PLoS One*, 9, e84534.
- Tremoureaux, L., Raux, M., Ranohavimparany, A., Morélot-Panzini, C., Pouget, P., & Similowski, T. (2014). Electroencephalographic evidence for a respiratory-related cortical activity specific of the preparation of prephonatory breaths. *Respiratory Physiology & Neurobiology*, 204, 64–70.
- Von Leupoldt, A., Vovk, A., Bradley, M. M., Lang, P. J., & Davenport, P. W. (2011). Habituation in neural processing and subjective perception of respiratory sensations: Habituation of respiratory sensations. *Psychophysiology*, 48, 808–812.
- Voskrebenez, A., Gutberlet, M., Klimeš, F., Kaireit, T. F., Schönfeld, C., Rotärmel, A., Wacker, F., & Vogel-Claussen, J. (2018). Feasibility of quantitative regional ventilation and perfusion mapping with phase-resolved functional lung (PREFUL) MRI in healthy volunteers and COPD, CTEPH, and CF patients. *Magnetic Resonance in Medicine*, 79, 2306–2314.
- Wan, L., Van Diest, I., De Peuter, S., Bogaerts, K., & Van Den Bergh, O. (2009). Repeated breathlessness experiences induced by hypercapnia. *Chest*, 135, 455–461.

How to cite this article: Valentin, R., Niérat, M.-C., Wattiez, N., Jacq, O., Decavèle, M., Arnulf, I., Similowski, T., & Attali, V. (2024). Neurophysiological basis of respiratory discomfort improvement by mandibular advancement in awake OSA patients. *Physiological Reports*, 12, e15951. <https://doi.org/10.14814/phy2.15951>