



HAL
open science

Evaluation of the reduction, tightening and gripping performance of an innovative set screw technology for instrumented posterior lumbar fusion: A biomechanical study

Francisco Ardura, David Chenaux, Hugues Pascal-Moussellard, Martin H Hessmann

► To cite this version:

Francisco Ardura, David Chenaux, Hugues Pascal-Moussellard, Martin H Hessmann. Evaluation of the reduction, tightening and gripping performance of an innovative set screw technology for instrumented posterior lumbar fusion: A biomechanical study. *Orthopaedics & Traumatology: Surgery & Research*, 2021, 107, 10.1016/j.otsr.2021.102918 . hal-04541306

HAL Id: hal-04541306

<https://hal.sorbonne-universite.fr/hal-04541306v1>

Submitted on 10 Apr 2024

HAL is a multi-disciplinary open access archive for the deposit and dissemination of scientific research documents, whether they are published or not. The documents may come from teaching and research institutions in France or abroad, or from public or private research centers.

L'archive ouverte pluridisciplinaire **HAL**, est destinée au dépôt et à la diffusion de documents scientifiques de niveau recherche, publiés ou non, émanant des établissements d'enseignement et de recherche français ou étrangers, des laboratoires publics ou privés.



Distributed under a Creative Commons Attribution 4.0 International License



Original article

Evaluation of the reduction, tightening and gripping performance of an innovative set screw technology for instrumented posterior lumbar fusion: A biomechanical study



Francisco Ardura^a, David Chenaux^b, Hugues Pascal-Moussellard^c, Martin H. Hessmann^{d,*}

^a Hospital Clinico Universitario de Valladolid, Calle Ramon y Cajal, 47008 Valladolid, Spain

^b Ruetschi Technology SA, Fabrikstrasse 35, 3286 Muntelier, Switzerland

^c Service d'orthopédie, CHU Pitié-Salpêtrière, pavillon Gaston-Cordier, 7(e) étage, 47-83, boulevard de l'Hôpital, 75013 Paris, France

^d Department of Orthopaedics and Traumatology, Academic Teaching Hospital Fulda, Pacelliallee 4, 36043 Fulda, Germany

I N F O A R T I C L E

Historique de l'article :

Reçu le 30 septembre 2020

Accepté le 30 décembre 2020

A B S T R A C T

Background. – Instrumented posterior lumbar fusion with top-loading pedicle screw systems (PSS) requires fully tightened set screws to achieve a secure fixation and symmetric load condition. This assumes a complete reduction of the rod by 90°, which is not always attainable in situ, especially under constraint. The objective of this work is to compare the mechanical performance of different innovative set screw technologies, which should improve the tightening process.

Hypothesis. – The hypotheses of the study are that modifications to the screw and screwdriver unit can (1) improve the quality of set screw tightening and (2) increase the axial gripping capacity of the construct.

Materials and methods. – The four set screw technologies under investigation include a standard set screw with a flat surface (F-S; control group), a set screw with a convex surface (C-S) and a shaft tip method screwdriver used in combination with both flat (F-STM) and convex set screws (C-STM). The quality of set screw tightening is categorized as follows: failed = the rod is not completely reduced; reduced = the rod is successfully reduced but the set screw is not correctly fixed; good = remaining cases. An axial gripping capacity test is performed by a universal testing machine (Instron®) with a force capacity of 5 kN.

Results. – Regarding the quality of set screw tightening, comparisons between F-S vs. F-STM, F-S vs. C-STM and between C-S vs. C-STM show statistically significant differences ($p < 0.001$). The axial gripping capacity test shows mean gripping forces of 1223 N (STD 331) in the F-STM group and of 1724 N (STD 168) in the C-STM group with statistically significant differences between both groups ($p = 0.003$).

Discussion. – Several biomechanical and clinical case studies have identified possible effects of misaligned rod-screw interfaces such as screw pull-out during rod reduction, screw loosening, screw or rod breakage, misalignment, adjacent segment degeneration and worsening of the clinical outcome. C-STM-technology thus supports controlled fixation in the sense of applying appropriate forces for correction or fixation during PSS assembly as well as friction-reduced final alignment and tightening with the aim to reduce implant loosening, hardware failure and reoperations, while respecting anatomical and biomechanical balance.

© 2021 Les Auteurs. Publié par Elsevier Masson SAS. Cet article est publié en Open Access sous licence CC BY (<http://creativecommons.org/licenses/by/4.0/>).

1. Introduction

Over the past decades, instrumented posterior lumbar fusion with pedicle screw systems (PSS) has remained the gold standard with increasing numbers of cases in a variety of indications requiring surgical treatment [1]. Fusion rates range from 85% for posterolateral fusion to 95% for posterior lumbar interbody fusion with quite large variations in the literature. However, in a recent literature review on published results from the 1980s until today

Abbreviations: ASD, adjacent segment degeneration/disease
FBSS, failed back surgery syndrome
PSS, pedicle screw system
STM, shaft tip method.

* Corresponding author.

Adresse e-mail : martin.hessmann@klinikum-fulda.de (M.H. Hessmann).

<https://doi.org/10.1016/j.otsr.2021.102918>

1877-0568/© 2021 The Authors. Published by Elsevier Masson SAS. This is an open access article under the CC BY license (<http://creativecommons.org/licenses/by/4.0/>).

relatively stable results over the last years were seen [2]. In contrast, several authors report an incidence of Failed Back Surgery Syndrome (FBSS) of between 10 and 40% [3–7], with risk of revision increasing with the years reaching well above 20% in recent years [8]. The FBSS incidence is also known to increase with more complex surgeries [3]. Two years postoperatively, the main reason for revision after adult spinal deformity surgery is implant failure (incl. rod and/or screw breakage or loosening), followed by infection, curve progression, pseudarthrosis, neurological deficit and other complications. Most of these revision reasons (67%) [8] are probably attributable to mechanical stress. In the long-term, however, adjacent segment degeneration (ASD) is increasingly relevant, with ASD rates of 79.8% and re-operation rates due to symptomatic ASD (adjacent segment disease) of 37.5% at a minimum of 15 years [9] or respectively an overall annual incidence of 2.5% [10] after lumbar arthrodesis because of degenerative diseases.

Postoperative factors leading to FBSS include altered biomechanics, which lead to increased stress on adjacent segments accelerating ASD [4] and, under asymmetric load conditions, to deformity [11], but also to increased stress on the PSS construct, possibly causing pedicle screw loosening, rod breakage or construct disassembly. Recent PSS developments aim to minimize the applied forces and thus possibly reduce the biomechanical complication rate after instrumented posterior lumbar fusion surgery.

Conventional top-loaded PSS involve a screw head wherein the rod is placed into a U-shaped seat and diametrically opposed to this seat; a threaded set screw tightened into the screw head. Clamping force of the system is mainly given by the ability of the set screw to convert the tightening torque applied onto it with a radial force acting on the rod. The set screw generally has an inner geometry matching with a screwdriver shaft which is used to apply the tightening torque through a torque limiting device. Therefore, at a constant torque, axial clamping force on the rod highly depends on friction within the thread which is the function of its properties, materials in contact, and possible constraints acting on the set screw.

The rod/screw head tightening process for the PSS construct is a crucial step for a secure fixation and symmetric load conditions. To achieve secure fixation of the rod into the screw head with a top-loading PSS, a complete 90° reduction of the rod relative to the pedicle screw head axis is required. But this step is not always attainable in situ, especially if the rod is under constraint, or if something is blocking the 90° screw head alignment to the rod.

Fig. 1 demonstrates the mechanical principles of standard flat set screw tightening under constraint:

- Alignment between set screw/screwdriver and rod \neq 90°;
- Reduction forces are transmitted asymmetrically via point contacts between set screw and rod;
- Asymmetrical force distribution on set screw thread results in tilting and increased friction during tightening;
- Anything limiting the alignment creates stress overload that leads to elastic deformation of the rod (cross-bow effect);
- Friction and stress overload results in material cold welding;
- Cold welding blocks any further reduction or alignment capabilities, preventing optimum alignment.

The objective of this work is to compare the mechanical performance of different innovative set screw technologies, the hypotheses are that modifications to the screw and screwdriver unit can:

- improve the quality of set screw tightening;
- increase the axial gripping capacity of the construct.

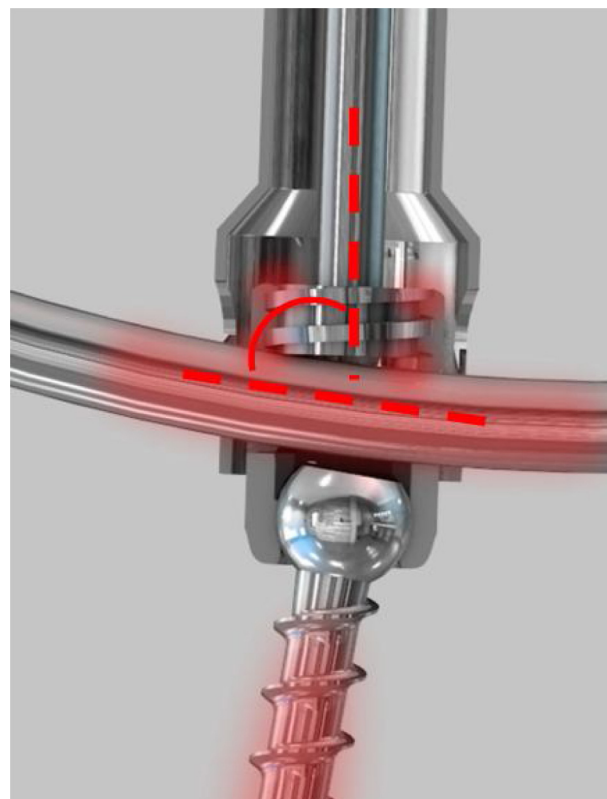

Fig. 1. Mechanical principle of standard flat set screw tightening under constraint.

2. Materials and methods

2.1. Test material

The four set screw technologies under investigation (Fig. 2) belong to the Neo Pedicle Screw System™ (Neo Medical S.A., Villetle, Switzerland), a PSS which comprises a variety of screws and rods made from titanium alloy as well as single-use instruments made from high performance polymers.

The standard set screw, commonly used in clinical practice, (control group) has a flat surface (F-S); in a second version the surface is rounded with a 10.5 mm convex radius (C-S). In the newly developed shaft tip method (STM), the stainless-steel set screwdriver passes through the set screw and protrudes by about 0.3 mm (0.1 to 0.4 mm) with its rounded tip, which has a 3 mm radius. This design ensures that the forces required for reduction are largely transmitted by the screwdriver instead of by the set screw, in order to avoid constraint in the screw head thread. This technology is studied with both flat (F-STM) and convex set screws (C-STM). Polyaxial pedicle screws as well as bent rods with a total length of 100 mm and 5.5 mm in diameter are used for testing. As the axial gripping capacity is a property of the rod/screw head connection, the choice of the pedicle screw sizes has no influence on the test.

In the STM technology, the reduction force is transmitted centrally in the final, particularly critical phase of reduction, primarily via the protruding round stainless-steel set screwdriver (Fig. 3a) This has four major effects:

- the reduction forces acting on the thread of the set screw are markedly reduced, which results in less friction between titanium and titanium and reduces the risk for cold welding;
- the centric load transfer prevents the set screw from tilting due to asymmetrical loading, which again reduces friction;

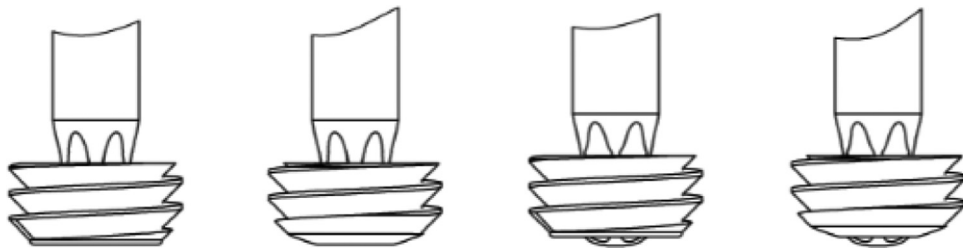

Fig. 2. Showing the four set screw technologies under investigation: F-S; C-S; F-STM; C-STM.

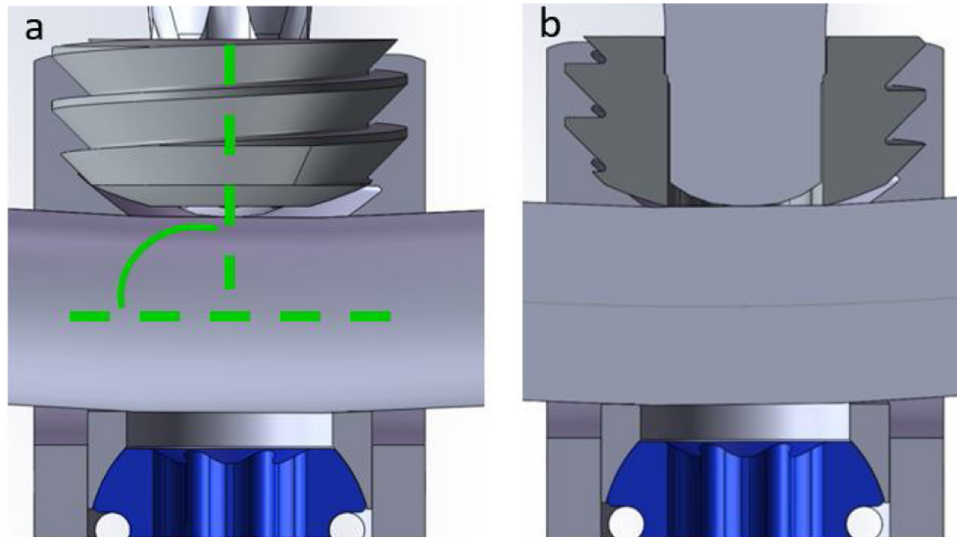

Fig. 3. Mechanical principle of C-STM technology: (a) end of reduction, and (b) set screw tightening.

- the reduction force is transferred by the round stainless steel tip of the set screwdriver, which reduces the contact surfaces and the friction between them;
- the main load is transmitted via a titanium/stainless steel pairing, which eliminates the problem of cold welding.

When the rod is fully seated in the screw head, perpendicular to the set screw/screwdriver (Fig. 3a), the set screw disconnects from the screwdriver shaft and synchronously the screw head is pulled out from the tower (Fig. 3b). This allows a set screw/rod contact for the final tightening.

2.2. Methods of assessment

The axial gripping capacity is defined as the maximum applied load across an interconnection mechanism within the first 1.5 mm of permanent displacement between the connected components [12].

An axial gripping capacity test, inspired by the ASTM F1798-13 standard [12], is performed by a mechanical laboratory (Ruetschi Technology AG, Muntelier, Switzerland). For this purpose, a universal testing machine (Instron®) with a force capacity of 5 kN was used (Fig. 4). Each set screwdriver assembly is placed on a bench test. The rod is inserted into the U-shaped pedicle screw head under controlled conditions (5° rod angle in the screw head/6.0 mm opening distance from set screw to screw head and 7.5Nm preload on the rod). Subsequently, the set screw is tightened with the respective set screwdriver until the limited torque of 10Nm is reached and then removed from the set screwdriver (Fig. 5).

Cases in which the rod is not completely reduced to 0°, meaning that the alignment between the set screw/screwdriver and

Table 1

Quality of set screw tightening by set screw technology.

	F-S (control)	C-S	F-STM	C-STM
Failed	9 (75,0%)	7 (58,3%)	0 (0,0%)	0 (0,0%)
Reduced	3 (25,0%)	5 (41,7%)	1 (16,7%)	0 (0,0%)
Good	0 (0,0%)	0 (0,0%)	5 (83,3%)	24 (100%)
Total n	12 (100%)	12 (100%)	6 (100%)	24 (100%)

rod ≠ 90°, are classified as ‘failed’ and those, in which the rod is successfully reduced to 0° but the set screw is not correctly fixed are classified as ‘reduced’. All others are classified as ‘good’. The axial gripping capacity test is performed for all F-STM and 18 C-STM cases. For this purpose, an axial load is applied to the rod with a constant speed of 5 mm/min (Fig. 6). The maximum load (axial gripping force), plotted graphically by the testing machine, which leads to a permanent displacement of the rod of 1.5 mm relative to the screw head, is recorded.

2.3. Statistical analyses

For comparisons between independent groups, the Fisher’s exact test is used for proportions and the nonparametric Mann-Whitney U exact Test is used for mean comparisons. Statistical significance is assumed at a p-value < 0.05.

3. Results

3.1. Set screw tightening

The results of the set screw tightening are classified by set screw technology in Table 1 and Fig. 7.



Fig. 4. Axial gripping capacity test set-up.

Comparative tests are performed for each group against the control group (F-S) and between C-STM and F-STM with statistically significant differences ($p < 0.001$) between F-S (control) vs. F-STM, F-S (control) vs. C-STM and between C-S vs. C-STM.

3.2. Axial gripping capacity

The axial gripping capacity test shows mean gripping forces of 1223 N (830–1794 N, STD 331, $n = 6$) in the F-STM group and 1724 N (1400–1997 N, STD 168, $n = 18$) in the C-STM group. The comparison of means detects statistically significant differences ($p = 0.003$) between both groups. The distribution of the measures is depicted in Fig. 8. The axial gripping force can't be measured for cases in which the rod reduction failed (F-S; C-S), since the rod is not clamped in the screw head.

4. Discussion

Achieving secure fixation with the required complete 90° reduction of the rod relative to the pedicle screw head axis is not always

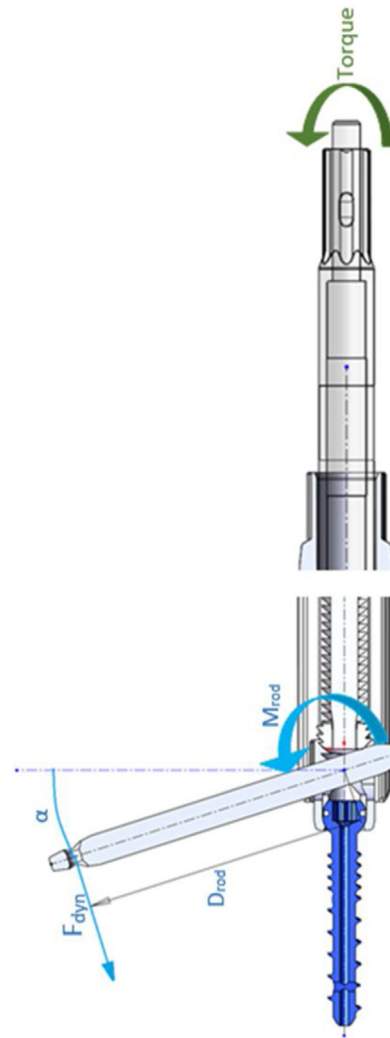

Fig. 5. Set screwdriver assembly with pedicle screw and rod.

attainable in situ, especially if the rod is under constraint, or if something is blocking the 90° screw head alignment to the rod.

The present mechanical test results confirm these findings in so far as that standard flat set screws fail to achieve full rod reduction in 75% of tested cases, and a good tightening of the set screw is achieved only in 25% of all tested cases if a moment of 7.5Nm is applied to the rod.

Voleti et al. [13] investigated the potential causes of set screw disengagements in three patients who underwent posterior spinal fusion surgery for idiopathic scoliosis correction and found specific traces in their microscopic analysis of one pair of set and pedicle screws. These include signs of asymmetric final tightening, rod interface marks and radial marks that indicate cyclic rod movement on the bottom side of the setscrew as well as isolated thread damage on one side. Marks in the saddle of the pedicle screw suggest that the rod did not have full contact. The authors conclude that increased forces, such as those found at the distal end of long fusions, may result in misaligned rod-screw interfaces, preventing proper tightening of the set screw. Paik et al. [14] observed in their biomechanical cadaver study that misalignment rates comparable to those in the present study (5 mm mismatch between the rod and the pedicle screw head) lead to screw pull-out during rod reduction in 44% of cases with normal bone and 50% with osteoporotic bone with a mean reduction in pullout strength of 48%. The clinical study by Ohba et al. [15] confirms that about 82% of loosened screws were

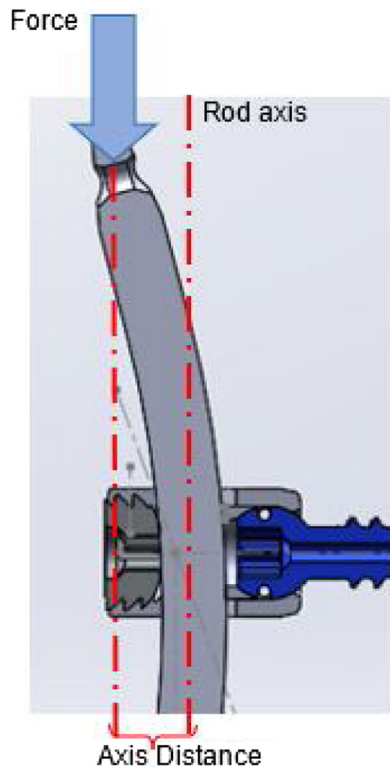

Fig. 6. Principle structure of axial capacity test.

pulled out during rod connection. In addition, the clinical results in terms of ODI and VAS pain demonstrated a significantly worse outcome in patients with screw loosening compared to those without screw loosening.

A finite element study [16] analyzing the effects of a constrained connection of misaligned pedicle screws and rods demonstrated forces of up to 1.0 kN for coronal and sagittal 6 mm mismatch correction. These forces compromise the screw-bone interface and affect the posture of the total lumbar spine on at least three levels cranial to the uppermost instrumented level. Concomitant effects observed at cranial adjacent levels, up to three levels above, are rotation of motion segments and remarkably increased

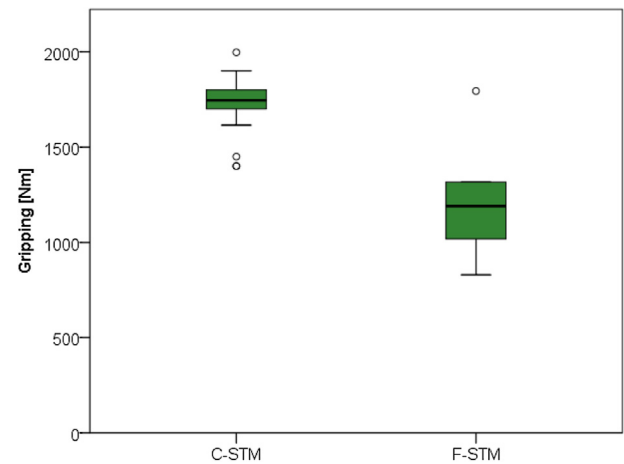

Fig. 8. Axial gripping force by STM groups. The axial gripping value is the highest force applied on the rod for a 1.5 mm displacement.

asymmetrical facet contact pressures of up to 6.3 MPa, indicating unphysiological and disbalanced joint loads. During flexion, the tissue volume at risk is larger in misaligned cases requiring reduction than in neutral cases. The authors conclude that even the reduction of relatively small rod/screw mismatches produces substantial unintended asymmetrical forces that induce a domino effect on adjacent segments, possibly resulting in a poorer outcome. The radiographs in Fig. 9 (Prof. Francisco Ardura, University Valladolid, Spain) show a case with a rod/screw mismatch at the cranial end of a bi-segmental posterior lumbo-sacral fusion and an asymmetrical rod alignment, indicating a stress overload in the construct. As can be seen in the 2-month and 6-month radiographs, the stress is transferred into the surrounding tissue, as indicated by the adjustment of the rod alignment and the scoliotic deformity, accompanied by bending, rotation and translation of the spine.

By applying stress-overload and friction to the construct during the final reduction and tightening process, not only the rod alignment and rod/screw interface stability are in question, but the entire construct and surrounding tissue could be under mechanical stress, which may lead to screw or rod pull-out [14–16], pedicle screw loosening [14,15], screw or rod breakage, misalignment [16], adjacent segment degeneration [16], or pain [15,16]. Therefore, a reduction of the rod to 90° with the lowest possible friction is of

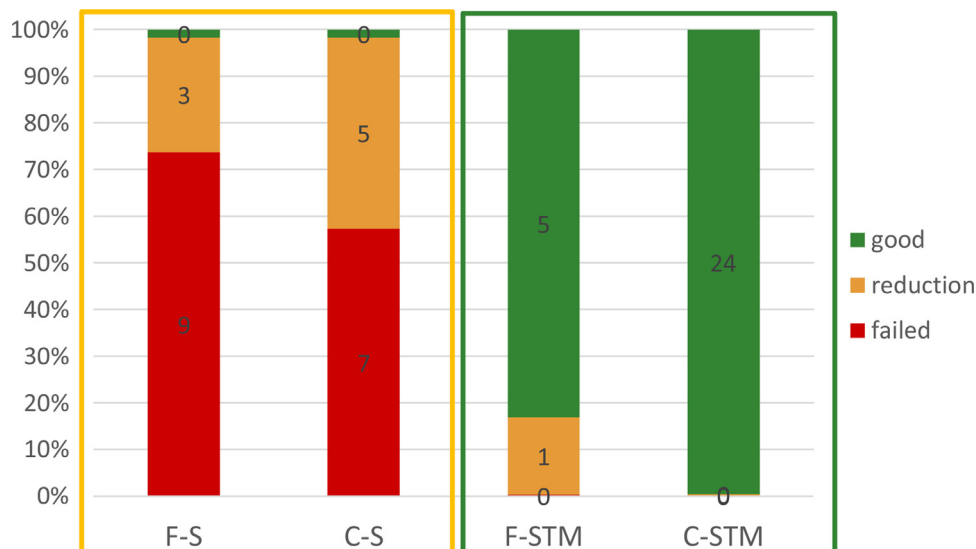

Fig. 7. Classification results of set screw tightening.



Fig. 9. A/P and lateral x-rays: directly, after 2 and 6 months postoperatively.

particular importance. Convex set screw tips, in which the surface contact and consequently the force transmission is centralized with increasing reduction, are intended to help overcome these problems.

According to the results presented herein, the STM technology shows a significantly better construct alignment and stability for both set screw versions, flat and convex, with significantly higher axial gripping forces of about 40% for the convex version, which could not be achieved with the design change of the set screw alone. Thus, STM-technology supports controlled fixation in the sense of applying appropriate forces for correction or fixation during PSS assembly as well as friction-reduced final alignment and tightening with the aim to reduce implant loosening, hardware failure as well as reoperation and to respect anatomical and biomechanical balance.

The weaknesses of the present study are the purely biomechanical approach and the relatively small number of cases. Clinical studies are needed to confirm the clinical relevance of the biomechanical observations.

5. Conclusion

To achieve a secure fixation and, if necessary, correction with a top-loading PSS, it is mandatory to fully tighten the set screw, which requires a complete 90° reduction of the rod relative to the axis of the pedicle screw head. The latter cannot always be achieved in situ, especially if the rod is under load. Compared to standard set screws, C-STM technology shows significantly better construct alignment and stability under constraint with axial gripping forces being about 40% higher for the convex version in comparison to the flat. Thus, C-STM-technology supports controlled fixation in terms of applying appropriate forces for correction or fixation during PSS assembly with friction-reduced final alignment and tightening to avoid unnecessary mechanical stress acting on the spine. The aim is to respect the individual anatomical and biomechanical balance in order to reduce the risk of implant loosening, hardware failure and reoperations.

Disclosure of interest

The authors declare that they have no competing interest.

Funding

This study was financially supported by Neo Medical SA.

Authors' contributions

FA: manuscript writing and editing.

DC: project development, data collection and management, manuscript editing.

HPM: manuscript review and editing.

MH: manuscript review and editing, submission, corresponding author.

Acknowledgement

We thank Nele Borm, Frictionless GmbH, Germany, for the statistical analysis and writing assistance.

Références

- [1] Deyo R, Gray D, Kreuter W, Mirza S, Martin B. United States Trends in Lumbar Fusion Surgery for Degenerative Conditions. *Spine* 2005;30:1441–5.
- [2] Makanji H, Schoenfeld AJ, Bhalla A, Bono CM. Critical analysis of trends in lumbar fusion for degenerative disorders revisited: influence of technique on fusion rate and clinical outcomes. *Eur Spine J* 2018;27(8):1868–76.
- [3] Shapiro CM. The Failed Back Surgery Syndrome, Pitfalls Surrounding Evaluation and Treatment. *Phys Med Rehabil Clin N Am* 2014;319–40.
- [4] Chan CW, Peng P. Failed Back Surgery Syndrome. *Pain Medicine* 2011;12:577–606.
- [5] Baber Z, Erdek MA. Failed back surgery syndrome: current perspectives. *J Pain Res* 2016;9:979–87.
- [6] Arts MP, Kols NI, Onderwater SM, Peul WC. Clinical outcome of instrumented fusion for the treatment of FBSS: a case series of 100 patients. *Acta Neurochir* 2012;154:1213–7.
- [7] Martin BI, Mirza SK, Comstock BA, et al. Reoperation rates following lumbar spine surgery and the influence of spinal fusion procedures. *Spine* 2007;32:382–7.
- [8] Pitter FT, Lindberg-Larsen M, Pedersen AB, Dahl B, Gehrchen M. Revision Risk After Primary Adult Spine Deformity Surgery: A Nationwide Study With Two-Year Follow-Up. *Spine Deform* 2019;7(4):619–26.
- [9] Maruenda JI, Barrios C, Garibo F, Maruenda B. Adjacent segment degeneration and revision surgery after circumferential lumbar fusion: outcomes throughout 15 years of follow-up. *Eur Spine J* 2016;25(5):1550–7.
- [10] Sears WR, Sergides IG, Kazemi N, Smith M, White GJ, Osburg B. Incidence and prevalence of surgery at segments adjacent to a previous posterior lumbar arthrodesis. *Spine J* 2011;11(1):11–20.
- [11] Aebi M. The adult scoliosis. *Eur Spine J* 2005;14(10):925–48.
- [12] ASTM F1798-13. Standard Test Method for Evaluating the Static and Fatigue Properties of Interconnection Mechanisms and Subassemblies Used in Spinal Arthrodesis Implants.
- [13] Voleti PB, Shen FH, Arlet V. Failure of Monoaxial Pedicle Screws at the Distal End of Scoliosis Constructs: A Case Series. *Spine Deform* 2014;2(2):110–21.
- [14] Paik H, Kang DG, Lehman RA, Gaume RE, Ambati DV, Dmitriev AE. The biomechanical consequences of rod reduction on pedicle screws: should it be avoided? *Spine J* 2013;1617–26.
- [15] Ohba T, Ebata S, Oba H, Koyama K, Haro H. The Risk Factors for Clinically Relevant Loosening of Percutaneous Pedicle Screws. *Spine Surg Relat Res* 2019;3(1):79–85.
- [16] Loenen ACY, Noriega DC, Ruiz Wills C, Noailly J, Nunley PD, Kirchner R, et al. Misaligned spinal rods can induce high internal forces consistent with those observed to cause screw pullout and disc degeneration. *Spine J* 2021;21(3):528–37.