



HAL
open science

Designing for Knowledge Capture in Fabrication Workshops

Clara Rigaud

► **To cite this version:**

Clara Rigaud. Designing for Knowledge Capture in Fabrication Workshops. Human-Computer Interaction [cs.HC]. Sorbonne Université, 2023. English. NNT : . tel-04148164

HAL Id: tel-04148164

<https://hal.sorbonne-universite.fr/tel-04148164>

Submitted on 2 Jul 2023

HAL is a multi-disciplinary open access archive for the deposit and dissemination of scientific research documents, whether they are published or not. The documents may come from teaching and research institutions in France or abroad, or from public or private research centers.

L'archive ouverte pluridisciplinaire **HAL**, est destinée au dépôt et à la diffusion de documents scientifiques de niveau recherche, publiés ou non, émanant des établissements d'enseignement et de recherche français ou étrangers, des laboratoires publics ou privés.



Distributed under a Creative Commons Attribution - NonCommercial - ShareAlike 4.0 International License

THÈSE

présentée à

Sorbonne Université

École Doctorale N° 391 (SMAER)

Sciences mécaniques, acoustique, électronique & robotique

Institut des Systèmes Intelligents et de Robotique (ISIR)

par

Clara Rigaud

pour obtenir le diplôme de

Doctorat de Sorbonne Université

DESIGNING FOR KNOWLEDGE CAPTURE IN FABRICATION WORKSHOPS

Soutenue le 15 Juin 2023

Nadine Couture	Professeure à l'ESTIA	Rapporteure
Theophanis Tsandilas	Chargé de recherche à l'Inria	Rapporteur
Anastasia Bezerianos	Professeure à l'Université Paris-Saclay	Examinatrice
Christian Simon	Maître de conférence à Sorbonne Université	Examineur
Gilles Bailly	Directeur de recherche au CNRS	Directeur de thèse
Yvonne Jansen	Chargée de recherche au CNRS	Encadrante

Abstract

Fabrication workshops are places equipped with machines and tools made available to the public. Members of the public, commonly called makers, can use this equipment to perform a variety of activities, going from digital fabrication to ceramics, for personal, amateur, professional or educational purposes. These places have evolved in parallel with the emergence of a “do-it-yourself” culture and peer-to-peer sharing, whereby makers not only share the workshop, but also share knowledge and experience to make use of these spaces. Such exchanges can take place directly, maker to maker, or through knowledge resources to track their progress, document their project on a wiki, build a tutorial so people can reproduce their project or add to a portfolio.

However, the creation of these knowledge resources is complex. Since it is done in parallel with the fabrication projects and different activities in the workshop, the additional task of creating such resources requires extra time and effort from makers. Creating these resources also involves the use of different tools to capture the content and transform it into a rich knowledge medium. This leads to many conflicts between resource creation and the main fabrication task, resulting in often incomplete or non-existent knowledge resources. Technology can help makers navigate these conflicts, but despite past research carried out on this subject resulting in different prototypes, most of the workshops remain unequipped with tools for knowledge resource creation.

This thesis informs why existing tools and prototypes have so far not been adopted, by answering the following question: which properties of a system matter to support makers in the creation of knowledge resources?

To answer this question, we first analyze existing studies and proposed tools and identify different objectives that makers may have when creating resources. From that we determine the different challenges they face and note that many of these challenges lie in the crucial moment of content capture within the workshop. Additionally, many of the existing tools focus on a particular objective of resource creation, which addresses some difficulties makers face, but leave out other issues and needs that makers may have. In a second step, we

focus on content capture and propose a framework to analyze this phase and understand what, when, where, why, how, and who captures content. From this analysis, we find that content capture is to be understood as an activity that can take place in different spaces and times, and that can take several forms. These different dimensions should be considered when designing tools to capture visual content. Based on these results, we propose a design concept covering a wide range of the framework's dimensions to support makers when capturing content related to their fabrication activity. We then present the results of a survey study gathering impressions of makers on the design concept and how they expect it to fit with their needs and within their respective workshops. While not all elements of the design concept found uniform appreciation, results suggest that (1) no single capture device would be able to address the various needs resulting from the diverse fabrication activities, (2) capture tools should enable makers to delegate control over some properties in a predictable way, and (3) the design of such tools should consider privacy and ethics by providing control over what is captured.

Finally, we discuss the new opportunities generated by this thesis to further inform the design of tools to support knowledge creation and sharing in the fabrication workshop.

Résumé

Les ateliers de fabrication sont des lieux équipés de machines et d'outils mis à la disposition du public. Les membres, appelés makers, peuvent utiliser cet outillage pour mener diverses activités, allant de la fabrication numérique à la céramique, à des fins personnelles, amateurs, professionnelles ou éducatives. Ces lieux ont évolué avec l'émergence d'une culture du "faire soi-même" et du partage entre pairs, par laquelle les makers partagent non seulement l'atelier, mais aussi les connaissances et l'expérience pour en faire usage. Ces échanges peuvent avoir lieu directement, de maker à maker, ou par l'intermédiaire de ressources de connaissances permettant de suivre leur progression, de documenter leur projet sur un wiki, de construire un tutoriel ou d'enrichir un portfolio.

Cependant, la création de ces ressources est complexe. Elle s'effectue en parallèle des projets de fabrication et des différentes activités de l'atelier, de telle sorte que la tâche secondaire de création de ces ressources exige du temps et des efforts supplémentaires de la part des makers. La création de ces ressources implique également l'utilisation de différents outils pour capturer le contenu et le transformer en un support de connaissances riche. Il en résulte de nombreux conflits avec la tâche principale de fabrication, ce qui se traduit par des ressources de connaissances souvent incomplètes ou inexistantes. La technologie peut aider les makers à résoudre ces conflits, mais malgré les recherches menées sur ce sujet et ayant abouti à différents prototypes, la plupart des ateliers restent dépourvus d'outils de création de ressources de connaissances.

Cette thèse informe sur les raisons pour lesquelles les outils et prototypes existants n'ont pas été adoptés jusqu'à présent, en répondant à la question suivante : quelles propriétés d'un système sont pertinentes pour assister les makers dans la création de ressources de connaissances ?

Pour y répondre, nous analysons d'abord les études et les outils proposés et nous identifions les objectifs que les makers peuvent avoir lorsqu'ils créent des ressources. À partir de là, nous déterminons les défis auxquels ils sont confrontés et notons que nombre de ces défis se manifestent au moment crucial de la capture du contenu au sein de l'atelier. En outre,

de nombreux outils existants se concentrent sur un objectif particulier de la ressource, ce qui permet de résoudre certaines difficultés auxquelles les makers sont confrontés, mais laisse de côté d'autres problèmes et besoins des makers. Dans un deuxième temps, nous nous concentrons sur la capture de contenu et proposons un modèle pour en comprendre les aspects. Cette analyse montre que la capture de contenu doit être considérée comme une activité qui se déroule dans des espaces et à des moments différents, et qui prend plusieurs formes. Sur la base de ces résultats, nous proposons un concept d'outil qui couvre un large éventail des dimensions du modèle. Nous présentons ensuite les résultats d'une enquête recueillant les impressions des makers sur le concept d'outil et sur la manière dont ils s'attendent à ce qu'il corresponde à leurs besoins et à leurs ateliers respectifs. Bien que tous les éléments du concept n'aient pas fait l'objet d'une appréciation uniforme, les résultats suggèrent que (1) aucun dispositif de capture unique ne serait en mesure de répondre aux différents besoins résultant des diverses activités de fabrication, (2) les outils de capture devraient permettre aux makers de déléguer le contrôle de certaines propriétés de manière prévisible, et (3) la conception de tels outils devrait prendre en compte la vie privée et l'éthique en fournissant un contrôle sur ce qui est capturé.

Enfin, nous discutons des opportunités générées par cette thèse pour informer davantage la conception d'outils pour favoriser la création et le partage de connaissances dans l'atelier de fabrication.

Acknowledgements

J'ai tant de personnes à remercier ici. Beaucoup d'entre elles sans qui je ne serais pas en train d'écrire ces mots qui concluent mon travail de ces trois dernières années.

Avant tout, cette thèse n'aurait pas été possible sans Gilles et Yvonne qui m'ont offert leur confiance en m'ouvrant les portes du monde de la recherche, alors que sur le papier, je n'étais pas vraiment un modèle d'excellence scolaire. Merci à tous les deux d'avoir été présents pendant ces trois années et de m'avoir permis de réaliser tout ça.

Merci à tous les copains, camarades et collègues de l'ISIR avec qui j'ai eu le plaisir d'échanger quelques rires, quelques mots et parfois quelques verres, Flavien, Benoit, Baptiste, Mokrane et la spéciale team H05, Théo, Téo, Vaynee, je suis vraiment heureuse de vous avoir rencontrés ! Dédicace spéciale à Nacho pour avoir sauvé la situation à plusieurs reprises et avoir contribué à me sentir si bien accueillie quand je suis arrivée. Merci également à Sylvie, Awatef, Adela, Anne-Claire, Philippe, Loïc, Laurent et toutes ces personnes si attentives à ce que tout se passe bien pour tout le monde dans le laboratoire.

Et ma si chère Aleks, après ces années à tes côtés, je suis heureuse de t'annoncer que tu passes le test de Turing (I trust you). On a vécu tant de choses toutes les deux, entre les aventures au milieu des alligators et ce long périple de trois ans. Merci pour tous ces rires et ces beaux moments et d'avoir toujours été présente pour déguster un bon tsar lazar ! L'énergie que nous avons créée ne mourra pas, et Україна переможе.

Un grand merci à toutes les personnes du Fablab de la Sorbonne qui font de ce lieu un endroit si chaleureux, Flora, Vincent, Pierre. Christian, merci d'avoir toujours été si attentif à moi pendant ces trois années, pour ta présence, et tes délicieux jus d'oranges pressées. Merci aussi à Stéphane et Manuel pour toutes les choses que vous m'avez apprises.

Je n'aurais pas survécu à ces dernières années sans mes précieux amis, qu'ils soient proches ou loin de moi, récents ou anciens, Bérengère, Maxime, Antoine, Axel, Simon, Pauline, Jean, Aline et toutes ces autres personnes avec qui j'ai eu tant plaisir à passer du temps. Merci d'avoir été là pour toutes ces marrades et pour les moments un peu plus durs, et surtout de tolérer les blagues nulles sorties de mon cerveau parfois fatigué.

Merci à ma famille pour leur amour et leur présence, même si je suis loin, Mutti, Fabio, mon Papa et ma Maman qui croyez en moi et m'avez toujours permis de suivre les voies qui me semblaient les plus justes dans ma vie. Je n'aurais pas pu faire ça sans vous.

Merci aussi à mes amis animaux, Mac DesMaqueraux, Maki, retourné au paradis des poissons rouges et qui m'a aussi un peu aidé pendant ces années de thèse, et bien sur, mon Billy, mon fils, tu es ma fierté.

Enfin, merci à Adriano Celentano, DakhaBrakha, Dan Deacon, Elton John, Ennio Morricone, Marvin Pontiac, Fat White Family, Nicolas Jaar, ODB, S8JFOU, SUUNS, Trio, Tyler, Unloved, The Warlocks, Wume, Yat-Kha, et bien sur Yello d'avoir accompagné les différentes humeurs de mon quotidien.

List of publications

Peer reviewed publications:

- ▶ Clara Rigaud, Gilles Bailly, Ignacio Avellino and Yvonne Jansen. 'Exploring Capturing Approaches in Shared Fabrication Workshops: Current Practice and Opportunities'. In: *Proceedings of the ACM on Human-Computer Interaction* 6.CSCW2 (Nov. 2022)
- ▶ Clara Rigaud, Gilles Bailly and Yvonne Jansen. 'Ressources de connaissances dans les ateliers de fabrication : objectifs et défis'. fr. In: *IHM '23: Proceedings of the 34th Conference on l'Interaction Humain-Machine*. Troyes: ACM, Apr. 2023

Doctoral consortium and workshops:

- ▶ Clara Rigaud. 'From the Makerspace to the Web: Creating Knowledge Resources from Fabrication Activities'. In: *Sixteenth International Conference on Tangible, Embedded, and Embodied Interaction*. TEI '22. New York, NY, USA: Association for Computing Machinery, Feb. 2022. ISBN: 978-1-4503-9147-4
- ▶ Clara Rigaud, Yvonne Jansen and Gilles Bailly. *Automating Documentation Considered Harmful (Some of the Time)*. en. Apr. 2022

Contents

Abstract	iii
Résumé	v
Acknowledgements	vi
List of publications	vii
Contents	viii
List of figures	x
List of tables	xiii
1. Introduction	1
1.1. Thesis statement and research questions	3
1.2. Research approaches and methods	4
1.3. Contributions	5
1.4. Overview of the thesis	7
2. Background: Fabrication Workshops and knowledge	9
2.1. Fabrication workshops history and evolution	9
2.1.1. 1950 - 2000: Birth and genesis	10
2.1.2. 21th century: Institutionalization and popularisation	14
2.2. Fabrication workshops, today	16
2.2.1. Working in a fabrication workshop	17
2.2.2. Fabrication workshops as a social and pedagogical place	19
2.3. Knowledge in fabrication workshops	21
2.3.1. Fabrication knowledge	21
2.3.2. Knowledge resources in fabrication	26
2.4. Conclusion	30
3. Creating knowledge resources from fabrication activities	33
3.1. Methodology	34
3.1.1. Definition of the search query	34
3.1.2. Exclusion criteria	36
3.1.3. Corpus analysis strategy	37
3.1.4. Limitations	37
3.2. Objectives and Challenges in the creation of knowledge resources	38
3.2.1. Represent a fabrication project	39

3.2.2.	Reuse one's work	40
3.2.3.	Support reflection	42
3.2.4.	Communicate	43
3.2.5.	Conclusion	44
3.3.	Using the framework to analyse tools	45
3.3.1.	Tools to support makers in the creation of knowledge resources	45
3.3.2.	Strategies to support the 4 objectives	52
3.3.3.	Conclusion	55
3.4.	Discussion	57
3.4.1.	Capturing and transforming the resources	58
3.4.2.	Representing and disseminating the resources	59
3.4.3.	Conclusion	61
3.5.	Conclusion	62
4.	Content Capturing for Knowledge Resources in Fabrication Workshops	65
4.1.	Framework: Content Capturing for Knowledge Resources in Fabrication Workshops	66
4.1.1.	Why to capture?	67
4.1.2.	What to capture?	70
4.1.3.	How to capture?	72
4.1.4.	When to capture?	74
4.1.5.	Where to capture?	75
4.1.6.	Who captures?	76
4.2.	How to Use This Framework	77
4.2.1.	Describing capture tools	79
4.2.2.	Comparing capture tools	81
4.2.3.	Conclusion	83
4.3.	Discussion	83
4.3.1.	Generative power	83
4.3.2.	Opportunity for design: Supporting Diverse and Distributed Activities	85
4.3.3.	Opportunity for design: Exploring Automated versus User Control	86
4.4.	Conclusion	86
5.	Exploring Visual Capturing Approaches	88
5.1.	Design concept	88
5.1.1.	Approach	89
5.1.2.	Capush	91
5.1.3.	Unit Types	92
5.2.	Study design	95
5.2.1.	Research Questions	95

5.2.2.	Survey Design and Approach	96
5.2.3.	Participant Recruitment	98
5.2.4.	Analysis and Report	98
5.3.	Findings	100
5.3.1.	RQ1: Current Capturing Practices	100
5.3.2.	RQ2: Exploration of Framework Dimensions Through Capush	102
5.3.3.	RQ3: Potential Issues and Concerns	110
5.4.	Discussion and Opportunities for Design	111
5.4.1.	Multiplicity and Variety of the Capturing Units	112
5.4.2.	Degree of automation: Mixed-Initiative Content Capture	114
5.4.3.	Social Context: Privacy and Ethics	116
5.5.	Conclusion	118
6.	Discussion, Future perspectives, and Conclusion	119
6.1.	What are the objectives of knowledge resources and the challenges faced by makers creating them?	119
6.2.	Which properties of a system matter to support makers in the capture of content from fabrication activities?	120
6.3.	Short term perspectives	122
6.3.1.	Refining the objectives, challenges and strategies identified	122
6.3.2.	Studying the properties of Capush in the field	124
6.4.	Long-term perspectives	124
6.4.1.	Further explore how automation of content capture and resource creation might benefit makers and the workshop	125
6.4.2.	Further explore how to extend capture tools	128
6.4.3.	Further explore how to extend knowledge resource creation tools	129
6.5.	Conclusion	130
	Bibliography	131
	A. Implementing Capush	147
	B. Asking ChatGPT for fabrication tips	150

List of Figures

2.1. The Milwaukee-matic-II	10
2.2. The Tech Model Railroad Club in 1960	11
2.3. Front cover of the January 1975 issue of the Popular Electronics magazine	13
2.4. First commercialised 3D printer by Charles W.Hull	14
2.5. European map of the Fablab network	16
2.6. Spatial layout of the Fablab at Sorbonne Université	18
2.7. Views of different workshops structured according to similar layouts	19
2.8. Schema showing the structure of a fabrication project	19
2.9. Two axis for describing knowledge	22
2.10. Illustrations of our example	24
2.11. Illustrations of our example	25
2.12. A view of the Sorbonne University's Fablab, structured as an open space	26
2.13. Physical examples of 3D printing parameters	27
2.14. Physical examples of 3D printed objects	27
2.15. Crochet Knitting Clock Instructables (introduction)	28
2.16. Look Mum No Computer animatronic video	30
2.17. Crochet Knitting Clock Instructables (steps)	30
3.1. Methodology for the literature review	35
3.2. Illustration of the search query	36
3.3. 4 objectives of knowledge resources	38
3.4. Software solutions	46
3.5. Documentation stations in the workshop	48
3.6. Mobile devices in the workshop	51
4.1. Illustration of how two chapters compare in their degree of focus	66
4.2. Objectives of knowledge resources vs objectives of content capture	67
4.3. Objectives of knowledge resources	67
4.4. Presets in the software controlling the laser cutting machine	68
4.5. Real time work in progress on Instagram	69
4.6. Gong et al. equip makers and workshops with various sensors	71
4.7. Community hardware devices in the workshop	72
4.8. Whitlock et al.'s AuthAR places sensors at different locations in the space	75
4.9. Capturing visual content with Dodoc and Protobooth	79
4.10. Visualising projects evolution with Protobooth meta-data capture	80
4.11. Figure illustrating 6 systems for capturing visual content	81
4.12. Pictures taken from steps of tutorials found on Instructables	85

5.1. Axis of the Capush design space	89
5.2. Physical mockups of the five unit types	93
5.3. Stills from the video shown to respondents	98
5.4. Overview of demographics and background of our respondents	99
5.5. Current practices in capturing content from fabrication activities	100
5.6. Frequency of help solicited by respondents to capture images and videos.	101
5.7. Reported likelihoods of taking pictures and recording videos with Capush	103
5.8. Reported usefulness for the 4 types of tags suggested	104
5.9. Capture and retrieval better than current	105
5.10. Reported appreciation of the camera units of Capush	106
5.11. Reported likelihood to capture the process and the result with Capush according to the activities	107
5.12. Appreciation of the manual control vs automated control	108
5.13. Appreciation of a shared local repository with tags	109
5.14. Appreciation of the overall system	110

List of Tables

3.1. Comparison of the 36 articles in our literature review	37
3.2. Analysis of tools through the framework of objectives and challenges	52
3.3. Strategies to support the creation of knowledge resources	56
4.1. Comparing vision-based capture tools using our framework	78
5.1. Description of the Capush units according to the dimensions of the framework	93
A.1. Overview of our proof of concept implementations sorted by feature.	148

Introduction

1.

Is there anything more unique to the human race than its special abilities to effectively transmit and refine knowledge about tool use?

Civilisations of yesterday and today were born of the particular ability of humans to understand their environment and to interact with it through increasingly numerous and sophisticated techniques, skills and tools, whose knowledge was transmitted over time scales exceeding that of a single lifetime [10, 93]. For a very long time, mastery of a tool was reserved primarily for the individual whose survival depended on it, whether for finding food or as a means to earn a living. Inventions, techniques and arts were transmitted within the social group, the family, then through writings and teachings.

With time, the environment has become more complex in many societies, where the level of comfort for all and mass production has made most of us lose our power to act directly on the things we interact with on a daily basis. We have reached a point where simply building the most common object, such as a toaster, has become a perilous task [126]. The mastery of know-hows and techniques became distant for many of those who do not have them as a source of livelihood.

Today, access to materials and knowledge through communication technologies has expanded these boundaries, so that learning to repair, to master a tool or a machine, to invent and create new things is possible. Situated learning which is the learning of concepts through interactions with physical objects in a collaborative way [80], is making a comeback. First, through communities of practice composed of people who want to learn certain techniques and gather around this

wish and exchange through it [145]. But also in the pedagogical field, with a growing interest in concrete concepts in addition to the more classical methodologies of the educational world. Places dedicated to this quest have appeared to welcome those who wish to do so, and are known under a variety of names such as fabrication workshops, Fablabs, makerspaces, ...

Fabrication workshops were born from the philosophy of giving the power over technologies back to all, and in this philosophy, sharing material resources, knowledge and skills is key. Workshops gather people around machines and tools made available to the public to design, build, repair, prototype, learn and invent things [34]. These people, commonly called makers, can use the equipment to perform a variety of activities, going from building a robot, to ceramics, for personal, amateur, professional or educational purposes.

These places have evolved in parallel with the emergence of a “do-it-yourself” culture and peer-to-peer sharing, whereby makers not only share the workshop, but also share knowledge and experience to make use of these spaces, giving rise to digital documents called knowledge resources.

Knowledge resources are at the heart of the philosophy and practices of fabrication workshops, however, creating them is a complex activity. Since it is done in parallel with the fabrication activities, happening at different moments of a project and while the maker can be in different places inside or outside the workshop, the additional task of creating such resources requires extra time and effort from makers [151]. Knowledge resources can be of different forms and their creation consequently requires the use of different tools to capture the content, transform it and represent it as a rich knowledge medium [138]. This leads to many conflicts between resource creation and the main fabrication task, resulting in often incomplete or non-existent knowledge resources.

Therefore, providing tools to support makers during this whole process is crucial. While a number of systems and tools have been already proposed to support makers in specific situations, there are still many cases where these tools are not well adapted. Indeed, there is a wide variety of activities happening in fabrication workshops, which themselves

are structured according to a variety of spatial layouts [8], and there are different reasons and manners to create content about a fabrication project. It is a challenge for a device to cover all of these cases, and most of the workshops remain unequipped with tools for knowledge resource creation.

1.1. Thesis statement and research questions

Exploring the habits and providing tools generic enough inside the workshop to fit different activities and purposes in knowledge creation, might lead to more effective approaches for the work of all makers, and help them to create richer and more reusable content and resources. Based on this statement, the question I address in this thesis is the following:

Which properties of a system matter to support makers in the creation of knowledge resources?

Answering this questions means first to understand why makers actually need support for knowledge resource creation. Only after understanding these needs, we can identify which properties of a system might help them in this task. Therefore, this question can further be broken down into two research questions. The first one is:

- ▶ **RQ1: What are the objectives of knowledge resources and the challenges faced by makers creating them?**

Answering this question will highlight that various objectives can be pursued by makers for their creation of resources, but also that there is a main challenge, transversal to these various objectives, which lies in the stage of the capture of content, happening inside the workshop.

Understanding this leads to the second research question:

- ▶ **RQ2: Which properties of a system matter to support makers in the capture of content from fabrication activities?**

To answer this second question, we first need to understand 1) the aspects of content capture, and 2) the current practices of makers capturing content, in order to 3) explore how these aspects and practices inform the properties of capture tools.

Therefore, this question is segmented in the following sub-questions:

- **RQ2.1:** What are the different aspects of content capture in fabrication workshops?
- **RQ2.2:** What are makers' current capturing practices during fabrication activities?
- **RQ2.3:** How do the aspects of capture inform the properties of capture tools in fabrication workshops?

For both of these research questions, I highlight opportunities for the design of tools to support makers in the creation of knowledge resources.

1.2. Research approaches and methods

During this thesis, I studied the thematic of knowledge related to fabrication and DIY activities with the goal to inform the design of tools to support makers creating knowledge resources alongside their fabrication projects. To do that, my approach is to understand, theoretically and empirically, the richness of makers' profiles, through their objectives in creating knowledge resources, and through the variety of their practices in the workshop, in order to identify the important aspects to consider when designing systems. This thesis lies in the field of Human-Computer Interaction (HCI) and makes use of the research methods of this field. Although I borrow some concepts, my thesis is not located in the fields of educational science, knowledge theory or fabrication. Also, the SARS-CoV-2 epidemic occurred shortly after I started working on this thesis, which led me to adapt my research methods according to the restrictions. The initial plan was to do a field study travelling to a variety of different workshops, then restrictions came in place concerning closure of spaces,

uncertainty when they would open again, and when they finally did, shortages of electronic components. The research methods used in this thesis are therefore based on theoretical literature reviews and a survey study:

- ▶ Theoretical literature review: I first reviewed the literature in a manner similar to a systematic literature review in the fields of education, design, fabrication and HCI to identify the different objectives of knowledge resources and challenges associated to their creation (RQ1). I report on this literature review in Chapter 3. I also conducted a second literature review, reported in Chapter 4, which focused on capturing content and capture tools in fabrication workshops, in order to identify their different aspects (RQ2.1).
- ▶ Survey study: We conducted a questionnaire-based online study to identify makers' practices regarding their content capture habits (RQ2.2) and to explore different properties of capture tools (RQ2.3). This survey is presented in Chapter 5.

1.3. Contributions

This thesis contains 4 types of contributions: survey, theoretical, empirical and artefact as categorised by Wobbrock and Kientz [149].

Survey and Theoretical contributions

Two contributions of this thesis consist in the analysis and structuring of the results (survey) brought by my two literature reviews. From each of these analyses, I extract a framework to describe and compare systems to support makers in the creation of knowledge resources, as well as to generate new research directions (theoretical).

First, in Chapter 3, I identify, from the literature, objectives and challenges related to knowledge resources that I classify according to their transversality and their specificity. By **RQ1**

structuring these challenges according to the identified objectives, I present a framework and illustrate how it allows to describe and compare different tools provided to support makers for given challenges. This helps to inform the design of tools both by highlighting some existing strategies, and also by showing the support needs for some common challenges, especially capture.

Second, in Chapter 4, I identify, from the literature, the different dimensions of content capture in the fabrication workshop, structuring this phenomenon according to the 5W+1H questions: Why to capture, What to capture, How to capture, When to capture, Where to capture, and Who captures. I provide a framework to describe this complex activity.

RQ2.1

RQ2.3

I then show how this framework can be used as an instrument for the analysis of content capture tools, and identify dimensions that are under-explored by existing tools.

Artefact contribution

From the dimensions identified by (RQ2.1), I envision a system in the form of a design concept called Capush, built from the design space generated by these dimensions, this time focusing on visual content capture (Chapter 5).

RQ2.3

Empirical contribution

Reporting on the results of the survey study (Chapter 5), I first provide an empirical contribution on the current practices of makers regarding their capturing practices and focusing on the different activities they perform in the workshop. Then, I report on the impressions of makers on the Capush design concept, and how they expect it to fit with their needs and within their respective workshops.

RQ2.2

RQ2.3

1.4. Overview of the thesis

Chapter 2

The context of this thesis is fabrication workshops, and I present here the history and evolution of these places. I explain how they became popular and are now places welcoming a variety of people performing various fabrication activities. I also explain how these places originated from a culture of knowledge sharing that still exists today. We learn that this knowledge sharing takes various forms, in particular digital documents such as tutorials, documentations or portfolios that are called knowledge resources in this thesis.

Chapter 3

Considering the variety of terminology used to describe knowledge resources across domains (tutorials, documentations, portfolios, ...), as well as the many barriers to their creation, my co-authors and I clarify the objectives and challenges of these resources (**RQ1**). Conducting a literature review, we identify 4 objectives and 8 challenges associated with knowledge resources. This analysis results in a framework that we use to analyze a selection of tools from the literature to support the creation of these resources. We find that the challenges associated with the different objectives can benefit from technological interventions at different moments of the resource creation, and in particular the moment of content capture.

Chapter 4

Focusing on what happens in the fabrication workshop, my co-authors and I try to better understand the different aspects of content capture. Content capture is analyzed along 6 dimensions: Why, What, Where, How, When, Who, giving rise to a second framework, this time focused on capturing in the workshop (**RQ2.1**). We demonstrate how this framework can serve as an instrument to describe and compare systems this time supporting makers in the specific step of content capture,

and then further develop around the directions to explore that this analysis generates. In particular, we highlight the need for tools to support diverse and distributed activities, as well as to explore automated versus user control of capture (**RQ2.3**).

Chapter 5

Based on the results of the previous chapters, my co-authors and I explore properties of a capture tool to support diverse and distributed activities and to automate some of these properties (**RQ2.3**). We derive three dimensions along which capturing systems can vary: multiplicity (number of capturing devices), variety (feature homogeneity between capturing devices), and degree of automation of features, from which we develop a design concept, termed Capush. Second, we report on the results of a survey study aiming at better understanding what the capture habits of makers are, and how they would consider a system such as Capush in their capture practice in the fabrication workshop (**RQ2.2, RQ2.3**). We learn that it is important to encourage the multiplicity of capture units and their variety according to the activities, as well as automating certain properties of the capture to reduce the physical and cognitive costs. We also highlight the implications of such tools in the workshop setting, in particular, considering privacy and ethics.

Chapter 6

The purpose of this final chapter is to discuss the limitations of the different research works constituting this thesis, as well as new research opportunities generated by them. I present the different progress on each of the sub-questions RQ1, RQ2, after which I discuss the limitations. Finally, I present research directions that can be taken in the short term and then in the long term to inform the design of tools for knowledge capture in the fabrication workshops.

Background: Fabrication Workshops and knowledge

2.

Fabrication workshops are spaces equipped with a variety of digital machines, tools, devices and materials that welcome a diverse audience of people from different background, profiles and practices, who work on projects, create, prototype or repair. Their particularity is that they are associated with a culture of sharing and mutual aid that encourages the creation and sharing of knowledge between peers around their fabrication practices. The users of these workshops are therefore used to share the knowledge associated with their projects, often via the internet. In this chapter, I describe the history of these places, alongside the raise of a culture of peer production and knowledge exchange, as to become places of learning, collaboration and social value. Then, I provide an overview of the knowledge creation practices that were born with, and became specific to these places. I will introduce the current practices of makers today, who create, share and use different kind of knowledge resources. These resources can take the form of digital documents that provide traces about projects made in the fabrication workshops, and are central to this thesis.

2.1 Fabrication workshops history and evolution	9
2.2 Fabrication workshops, today	16
2.3 Knowledge in fabrication workshops	21
2.4 Conclusion	30

2.1. Fabrication workshops history and evolution

Fabrication workshops are a type of communal space that found their origin in the second half of the 20th century and evolved with the different technological progress made during this era, in particular the development of computers, the internet and later digital fabrication machines. These types of spaces have developed alongside the democratisation

of hobbyist hands-on practices, the growing access to the internet and to digital machines [81, 154]. The appearance and growth of these places has also come with the construction of a culture of itself, as to become a network of knowledge and resources freely shared between communities (almost) all over the world [50]. This section provides an overview of the origins and history of these places.

2.1.1. 1950 - 2000: Birth and genesis

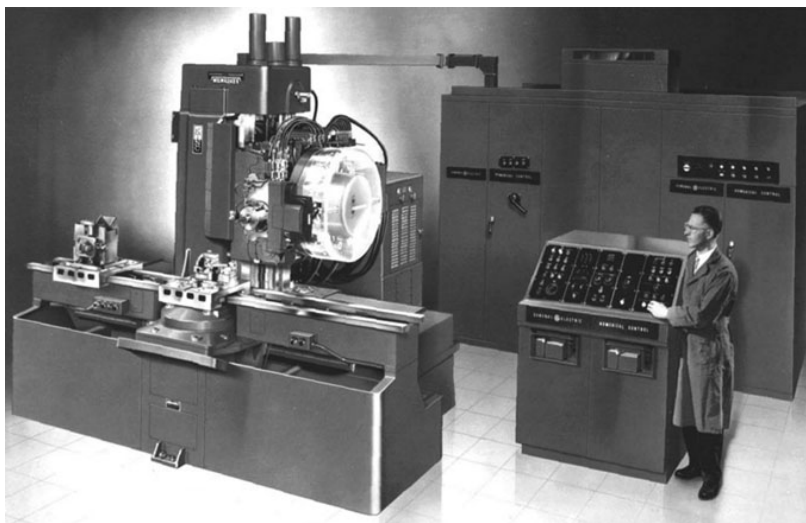

Figure 2.1.: The Milwaukee-matic-II, the first commercialised Numeric Control machine

In the 1950s, several factors came together at the Massachusetts Institute of Technology, that would allow the emergence of both a new field of research on manufacturing machine automation, and the birth of a culture of making and accessing free knowledge [50, 81]. Indeed, one of the first Computer Numerical Control (CNC) machine named the “Cincinnati Milacron Hydrotel” was born in one of the rooms of the institute in 1952 from one parent milling machine and another TX-0¹[154].

This would be one of the first stones to the evolution of CNC machines, which would be expanded to other machine tools such as drilling machines or lathes², as well as the birth of new disciplines to create designs with these machines: Computer Aided Manufacturing (CAM) and Computer Aided Design (CAD) [154]. In 1958, the “Milwaukee-matic-II”, shown in Figure 2.1, would become the first machine to be commercialised [154].

1: The TX-0, for Transistorized Experimental computer zero was one of the first transistorised computers and was built in 1956. It was the first computer at MIT which allowed for direct interaction and didn't require the use of punch cards.

2: Drilling machines and lathes are machines used in industry to cut metal.



Figure 2.2.: The Tech Model Railroad Club in 1960, source: MIT Museum

Steven Levy, in his book “Hackers: Heroes of the Computer Revolution” [81], traces the history of what became the hacker culture. He starts his book by telling the story of a group of passionate students in 1959 at MIT. These students were part of the *Tech Model Railroad Club* and spent most of their time together working on the control system of their miniaturised railroads. During these times, it is said that they developed their own language, and among a set of invented words, used the word “*hack*” to call an undertaken project or a product built with passion, involving “innovation, style and technical virtuosity” [81]. These students had access to the TX-0, during times when “officials” were not using it, and started creating code to compile assembler or make the computer play music during the night. The first hackers were born, and with them the first hacker culture and ethic. Levy [81] enumerates the different moral rules established by this group of students at the time:

1. “Access to computers—and anything that might teach you something about the way the world works—should be unlimited and total. Always yield to the Hands-On Imperative!”

2. “All information should be free.”
3. “Mistrust Authority—Promote Decentralization.”
4. “Hackers should be judged by their hacking, not bogus criteria such as degrees, age, race, or position.”
5. “You can create art and beauty on a computer.”
6. “Computers can change your life for the better.”

This way of thinking continued to spread between the different members at first, then between universities from the 1960s onward, notably with the appearance of Arpanet³ which allowed these hackers to exchange programs and techniques between themselves [81].

The 1970’s saw the emergence of a multitude of electronics enthusiasts, who embarked on projects presented by magazines such as *Popular Electronics*⁴, *Radio Electronics*⁵ or vendors of kits to build such as *Heathkit*⁶ [81]. Hobbyists could now discover and experiment in areas that had previously been reserved for the privileged few in the academic or industrial world. In particular, 1975 was a landmark year for the magazine *Popular Electronics* which offered for the first time to the general public to build a computer sold in kit form at \$400 [81]. This was followed by the democratisation of the first affordable computers in the 1980s.

From universities to the home, different kinds of communities began to come together to collaborate and exchange knowledge directly. The first spaces dedicated to the practices between programming and electronics seem to have appeared in Germany in the early 1980s. The *Chaos Computer Club*⁷, created in 1981 quickly inspired people in the United States who set up in their turn the first *Hackerspaces*, gathering again in a place dedicated to discovery, learning, experiments and creation [81]. The spirit of knowledge sharing in this hacker universe quickly began to spread on the Internet.

The next 20 years saw the number of internet users grow, the free knowledge ethic spread on the online forums. The *Free Software Foundation*⁸, which would later give rise to the GPL licenses⁹, was created in 1985, institutionalising for the first time the philosophy of knowledge sharing by making computer programs free and open source. This philosophy was also propagated in the Do-It-Yourself and Do-It-With Others movements favouring peer production and peer learning.

3: Arpanet was the first decentralised network allowing to share data over the United States

4: https://en.wikipedia.org/wiki/Popular_Electronics

5: <https://en.wikipedia.org/wiki/Radio-Electronics>

6: <https://en.wikipedia.org/wiki/Heathkit>

7: https://en.wikipedia.org/wiki/Chaos_Computer_Club

8: https://en.wikipedia.org/wiki/Free_Software_Foundation

9: https://en.wikipedia.org/wiki/GNU_General_Public_License

HOW TO "READ" FM TUNER SPECIFICATIONS

Popular Electronics

WORLD'S LARGEST-SELLING ELECTRONICS MAGAZINE JANUARY 1975/75¢

PROJECT BREAKTHROUGH!

World's First Minicomputer Kit to Rival Commercial Models...

"ALTAIR 8800" SAVE OVER \$1000



ALSO IN THIS ISSUE:

- An Under-\$90 Scientific Calculator Project
- CCD's—TV Camera Tube Successor?
- Thyristor-Controlled Photoflashers



TEST REPORTS:

- Technics 200 Speaker System
- Pioneer RT-1011 Open-Reel Recorder
- Tram Diamond-40 CB AM Transceiver
- Edmund Scientific "Kirlian" Photo Kit
- Hewlett-Packard 5381 Frequency Counter

Figure 2.3.: Front cover of the January 1975 issue of the Popular Electronics magazine, introducing the Altair 8800 in kit for \$400

Terms like *hactivism* then gave birth to *maktivism* and *craftivism* [33] formed by people taking power over technology, this time physical. All these movements and the communities formed around them had for essence the free access to knowledge, to the machines and tools, so that whoever wants it can reuse and build on the productions and the discoveries made by others.

Meanwhile, CNC machines and CAD/CAM had continued to develop in the industry. 1980 and 1990 saw the emergence of additive manufacturing, a technology consisting in adding material layers by layers to create a three dimensional physical object based on virtual 3D CAD models. The first commercialised 3D printer shown in Figure 2.4 was created by Charles W. Hull in 1984. Additive manufacturing showed



Figure 2.4.: First commercialised 3D printer by Charles W.Hull

great potential in industrial applications as it would enable rapid prototyping, speed up the production, allow to make virtual objects tangible and that with any shape and geometry with a reduced cost [154]. However, most of these machines were still protected by patents at the time and would not be made available outside of the industrial context until the early 2000's.

Between the philosophy of sharing and progress in computer assisted manufacturing machines, researchers and industrialists of the second part of the 20th century had laid the first stones of an era where knowledge and technology would be made accessible to all.

2.1.2. 21th century: Institutionalization and popularisation

In the early 2000's at the Center of Bits and Atoms at the MIT, Neil Gershenfeld began teaching a course on computer controlled lasers, 3D printing and electronics. He saw in these different activities an opportunity for learning by doing and gradually developed the concept of Fabrication Laboratories (or FabLab for short). Fablabs are a model of workshops providing machines and materials to users, and inspired by the spirit of sharing and free access to technology and knowledge. They are governed by a charter¹⁰, which stipulates among other things that knowledge must be shared, that

10: <https://fab.cba.mit.edu/about/charter/>

each project created in the Fablab space must be documented so that anyone can reproduce it [50].

Little by little, the price of machines went down and the plans and methods to drive them could be shared all around the world, for instance with projects like *RepRap*¹¹, which made the first open-source 3D-printing machines. This allowed the productions of different objects to be decentralised, and people to collaborate on projects from different places of the world and was considered a third industrial revolution [50, 63].

In 2005, Dale Dougherty launched a magazine in the vein of what was then *Popular Electronics*, featuring do-it-yourself fabrication projects. He named this magazine “Make Magazine” and created the “Maker” movement, sowing the seeds of a new community of enthusiasts of inventions, hacks and do-it-yourself projects. These makers can meet at dedicated events called Maker Faires, which are still going on today [34, 100].

During this decade, the number of Fablabs and similar workshops had continued to grow, and the 2010’s saw the creation of an international network of Fablabs, connecting previously informal organisations together. Figure 2.5 shows the European map of all the Fablabs belonging to the Fablab network. The Fab Foundation¹² created in 2009, had the mission to offer sources of knowledge and materials for fabrication workshops in the world. Gershenfeld also created the FabAcademy, a distributed training program connecting several Fablabs together in a virtual campus for a few months, to learn the different practices of digital fabrication and electronic prototyping, as well as the practices of project documentation [50]. The creation of knowledge resources related to fabrication activities became an important part in the journey of the maker in fabrication workshops.

11: RepRap for Replication Rapid Prototyper, is an open source 3D printer whose components can be manufactured with the machine itself. The machine can thus self-replicate.

12: <https://fabfoundation.org/>

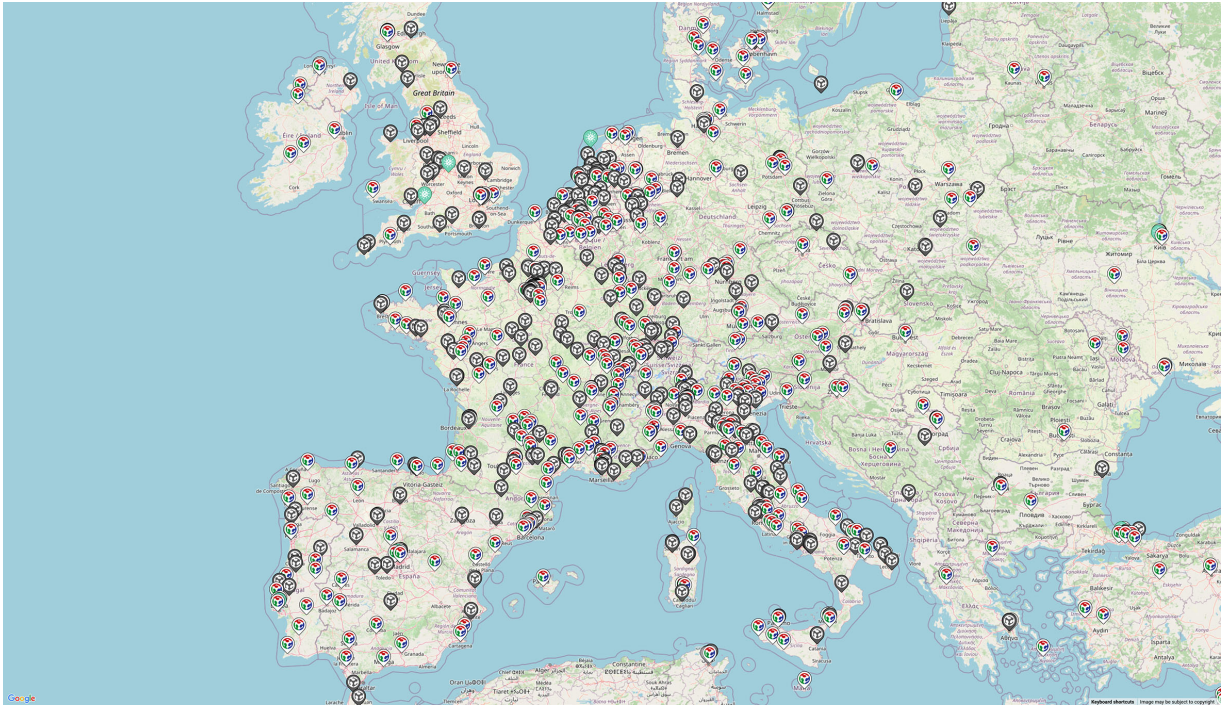

Figure 2.5.: European map of all the active and planned Fablabs belonging to the Fablab network - Source <https://www.fablabs.io/labs/map>

2.2. Fabrication workshops, today

Since 2010, many models of fabrication workshops have been developed in different places, especially in libraries, schools, universities, and other innovation or co-working spaces [12, 100, 147]. Many names are used to refer to fabrication workshops, such as 100kgarages, telecottages, innovation labs, co-working spaces, media labs in addition to Fablab, maker-spaces or hackerspaces [63]. If these spaces have in common that they offer users access to a range of numerically controlled machines, they are difficult to define [17, 63]. They vary in aim, ambition, in their business models, especially in terms of subsidies and management, and in the audience they welcome [152]. Indeed, some of these places are open to all, with relatively cheap subscriptions, following a policy of valuing innovation by encouraging users to share their knowledge through documentations and wikis, while others operate more on a service model, paid by the user. In the latter, makers become customers which can complicate expectations of knowledge sharing. In this thesis, I mainly focus on the first ones, places open to all, as my focus is on knowledge sharing. I explore in this section how these workshops

work in practice, and how they became places of social and pedagogical interest.

2.2.1. Working in a fabrication workshop

Not all workshops are identical and the way of working depends at least partially on the equipment and the layout of a specific space. The Fablab network proposes a list of basic equipment, which can be found in most of the workshops, but some workshops specialise and equip themselves according to the demands of the public or to their own interests and financial capacity [100]. In practice, all workshops have one or more 3D printers, laser cutters, vinyl cutters and CNC mills for large cuts and for the creation of electronic circuit boards [8, 98, 103]. There are also generally tools and materials for electronic prototyping: soldering stations, measuring equipment, micro-controllers, electronic components and sensors [12, 17]. Some workshops offer textile machines and materials, sewing machines, digital embroidery and weaving machines, silkscreen printing facilities, pottery materials, woodworking or even cooking and biology [17]. Figure 2.6 shows the equipment of the Fablab at Sorbonne Université as it was in 2019.

The workshops are also equipped with software resources for 2D and 3D design, for programming and for the control of different digital machines [30, 46].

Annett et al. [8] explored how these different kinds of workshops are spatially organised. Using a case study of several workshops, they showed that most of these places are open spaces with a series of areas dedicated to certain activities, including a computer design area, a woodworking area, an electronics area and so on. Figure 2.7 from their paper shows how different spaces happen to be structured following similar layouts. They also show that some areas are separated and reserved for noisy or dirty activities and machines [8].

People attending the workshops are working on different kinds of projects often involving many kinds of fabrication activities. Makers projects may extend over a more or less long period, sometimes including several iterations [135]. As shown Figure 2.8, fabrication projects can be described as a

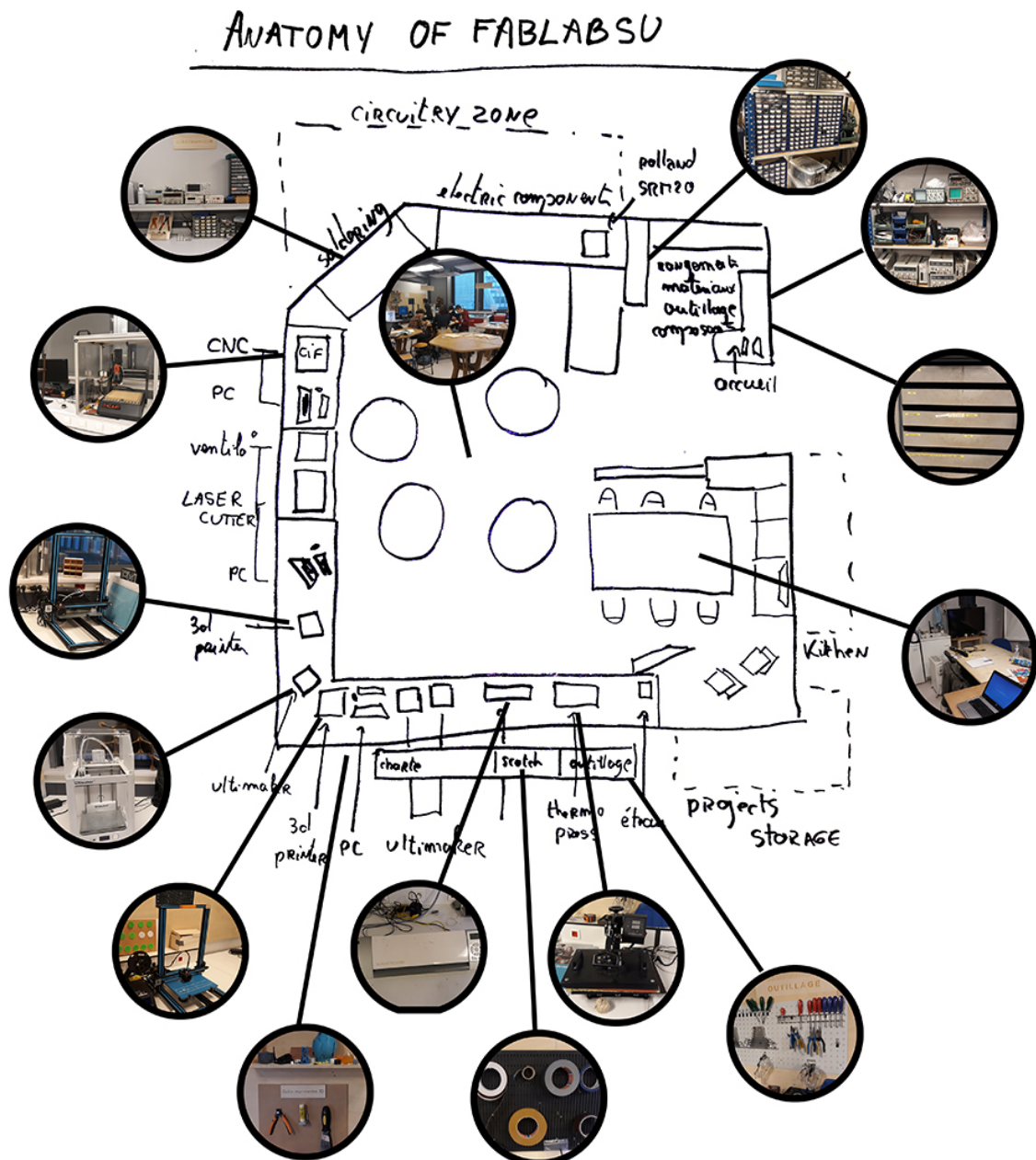

Figure 2.6.: A schema representing the spatial layout of the Fablab at Sorbonne Université in 2019.

sequence of activities taking place inside the workshop, or outside the workshop, depending on whether they require the use of space or not.

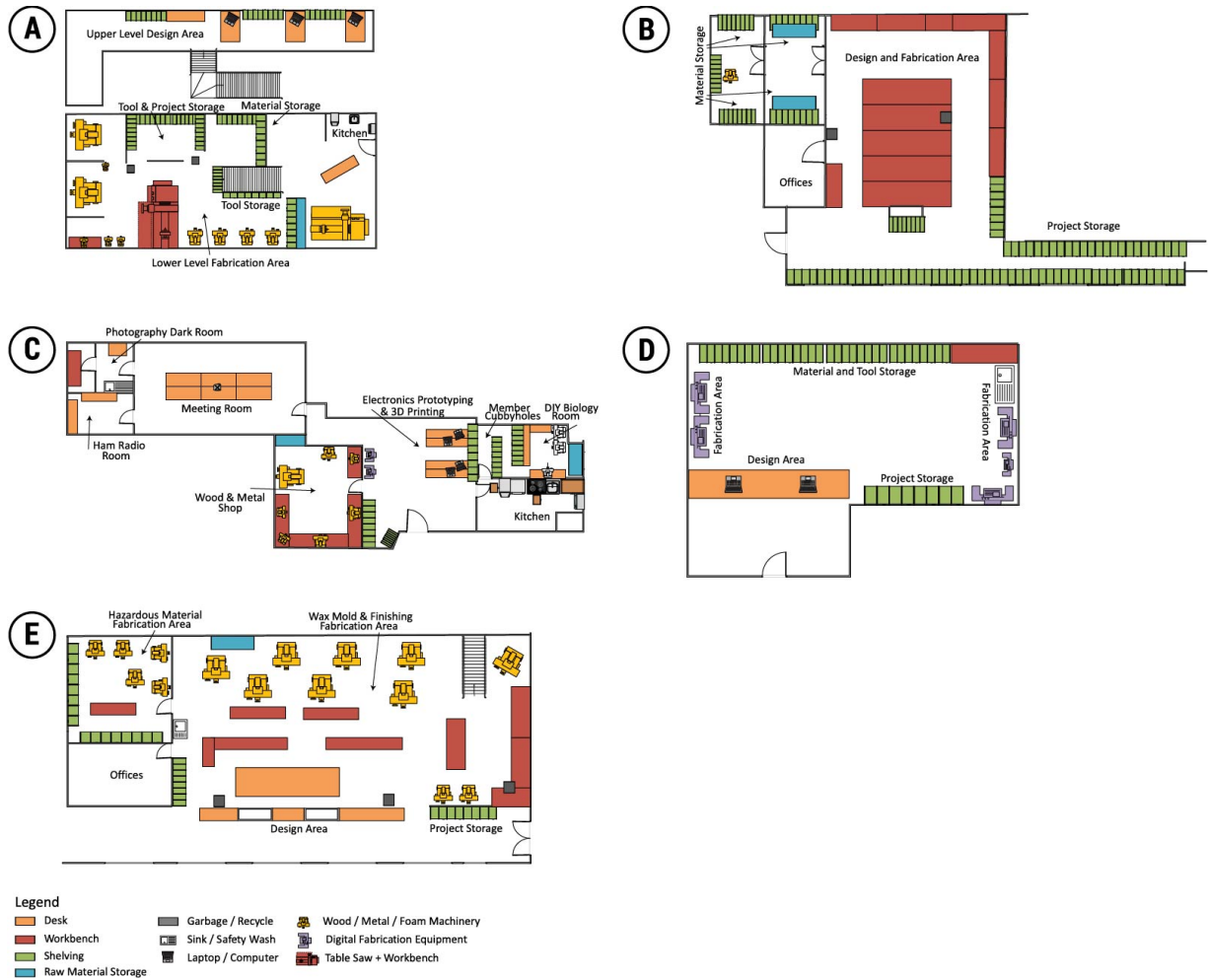

Figure 2.7.: Diagram borrowed from Annett et al. [8], showing views of different workshops structured according to similar layouts

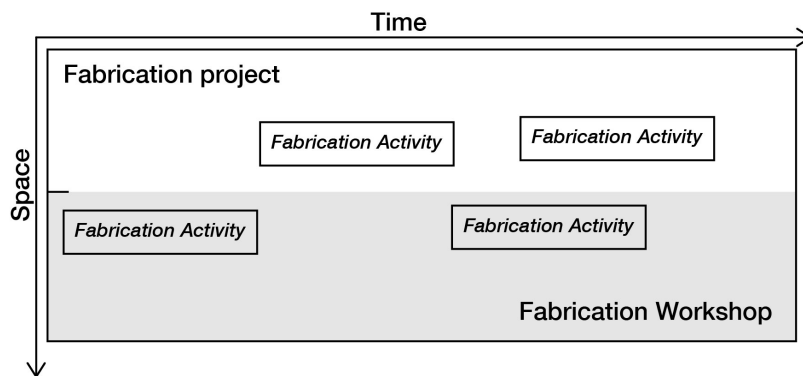

Figure 2.8.: Fabrication projects can spread over a more or less period of time. They are composed of different fabrication activities, happening at different places, inside or outside of the fabrication workshop

2.2.2. Fabrication workshops as a social and pedagogical place

Beyond their tools and materials, fabrication workshops are valued for the pedagogical and social opportunities they provide as community spaces, and continue developing prac-

tices between craft, engineering and digital technologies. Indeed, important social dimensions also emerges from these fabrication workshops [120, 125]. Some of these spaces have a political agenda, valuing access to education, giving access to power over technology, the future, and inequities [47, 63, 89, 130]. As an example, many spaces host repair workshops to encourage the act of *making* over the act of *consuming* [100]. Some can be considered as “third places” [4, 125], a type of social places independent to the workplace, school or the home [95]. They allow the development of local communities and are appreciated for the social and mutual care values they allow between users [63, 130].

In the field of education, activities around fabrication, learning by doing, have proven to be particularly successful from the youngest audience to university students [98, 100, 117, 143]. The activities allow for the learning of scientific, technical and creative concepts, while stimulating risk taking, interest, participation and collaboration [46, 120, 143]. We can indeed find making activities in US schools from Kindergarten to middle school, in schools of design and architecture and in universities [1, 89, 116]. Special non profit organisations also focus on creating bridges between making and education such as the *The Maker Ed*¹³ [100].

13: <https://makered.org/>

Beyond the mastery of tools, dexterity and concepts, fabrication projects promote the learning and mastery of a technical language, the communication of one’s knowledge and practices [45, 85, 86], and also allow learners to develop a critical view of their work, their position within a group, and the impact of the technology on their environment [116, 143].

As a summary, today’s fabrication workshops are places that welcome a wide audience, varying in degree of expertise, professions and practices [17, 63]. Understanding the history behind their development allows to understand the philosophy and peculiarity of these places, in particular regarding the spirit of sharing. This audience continues to grow as the disciplines and knowledge tend to become more and more accessible to anyone who wants to invent, make, create or learn. While in much of the literature the term “makers” is used to refer to people using this places, it does not refer to one homogeneous population [57, 109] as they may not come

from the same cultural background [119], and may not be the same people as the first hackers I talked about earlier, but this philosophy of sharing and helping each other continues. These exchanges may happen physically through the emergence of local communities gathering around events or common projects, through the educational environment and the teachings around the practices or through the charter of the place which encourages to give back its knowledge to the common [42, 63, 89].

2.3. Knowledge in fabrication workshops

After considering how a culture of knowledge sharing was born from a hacker and DIY ethic and how this culture became a foundation to today's workshops, I change perspective to that of the individuals working in the fabrication workshops, and how they interact with this knowledge related to fabrication. During a fabrication activity, throughout a project and over a lifetime, each maker creates, uses and enriches themselves with a considerable amount of knowledge. From the manipulation of a tool to its expertise, or from the reference of an electronic component to the documentation of an entire project, different kinds of information are used and sometimes shared between makers. In this section, I define this knowledge and its various components. Then, I explain how different elements of information are used, archived, shared between makers, and reused, in the form of rich documents that have been given a lot of different terms, and which I call here knowledge resources.

2.3.1. Fabrication knowledge

There are many ways to describe knowledge. I approach here the definition of knowledge related to fabrication domains from a grid of general knowledge description provided by Jong and Ferguson-Hessler [69]. These authors have built a grid to define knowledge from a large literature review, taking into account the different models of knowledge described in

various fields, and apply it in particular to the context of task completion. As shown Figure 2.9, knowledge is described according to 2 axes: the *type* of knowledge and the *quality* of the knowledge.

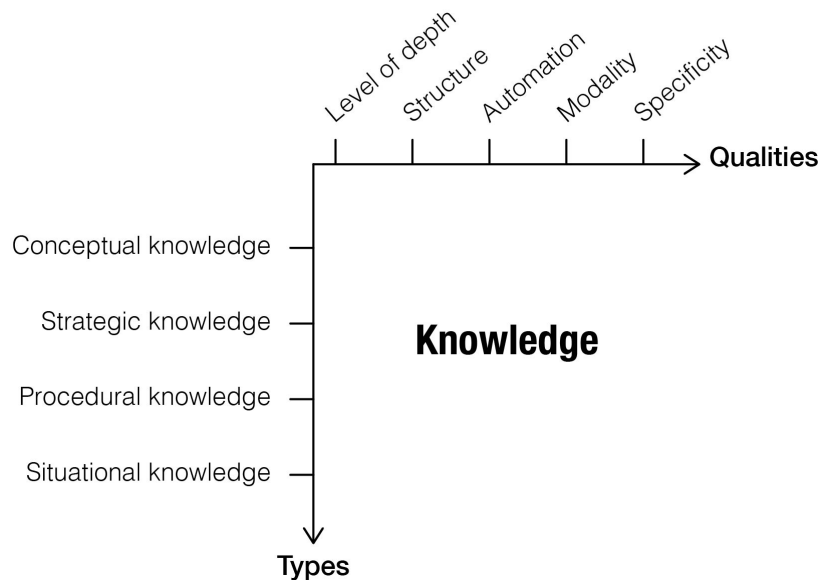

Figure 2.9.: Jong and Ferguson-Hessler describe knowledge according to two axis: type of knowledge and quality of knowledge.

I define here the different categories of knowledge used in the fabrication domain from this grid, starting with the different *types*:

Conceptual knowledge

Conceptual knowledge is the knowledge of a fact, similar to the notion of declarative knowledge used in other fields. Applied to our context, in the case of fabrication, makers are exposed to many rules and parameters for the operation of machines and software. They also use different rules and physical principles. For example a statement like “the pattern used for filling in a 3D print affects the strength of the resulting object” is conceptual knowledge, and so is “ $U = R.I$ ”.

Strategic knowledge

Strategic knowledge defines a plan of action, the knowledge of the sequence of actions required to complete a task. In our case, it would be the sequence of activities done within the scope of a project, or the sequence of operations constituting an activity.

Procedural knowledge

Procedural knowledge is defined as the actions and manipulations that allow to go from one state to another. For example, in our case, making a soldering point, deburring a part, stripping a wire or starting a laser cut.

Situational knowledge

Situational knowledge is defined as the knowledge of the context in which one finds oneself. Context allows information to be interpreted in one way or another. In the case of fabrication, context is particularly important because the stages of a project usually consist of a variety of activities. The use of the term "tool" or "cut", for example, is not the same in the context of design software as it is in a wood-working shop. The concept of "resistance" is not the same in the context of electronics, which in this case is a measure of the opposition of an object to an electric current, while in the context of a physical object it is the ability of that object to withstand a force applied to it.

The second axis of description is the quality of the knowledge, Jong et al. [69] identify 5 variables: *level of depth*, *structure*, *automation*, *modality* and *specificity*.

Level of depth

Level of depth of knowledge is different between experts and novices. Experts have a *deep level* of knowledge and are able to approach a problem with a certain capacity of abstraction. Novices, on the other hand, tend to approach a problem at a *superficial level*, with a more basic representation.

Structure

The structure of knowledge defines the way in which knowledge is internally represented, including how each concepts are connected to one another or not. Experts knowledge is *structured* in units (chunks) with connections between different concepts. On the other hand, the knowledge of novices is *structured* differently, as the concepts they know are isolated from each other.

Automation

Novices and experts also have a different degree of knowledge, what Jong et al. [69] call *automation* of knowledge. This concept of *automation* is close to the concept of explicit vs tacit knowledge. The more the person is expert, the more the processes guiding their methodology are automated and tacit. On the contrary, novices tend to follow step-by-step reasoning, more explicit.

Modality

The fourth variable of knowledge quality is the *modality*, that is the form in which this knowledge is represented, which can be a text, a picture, a video, a diagram, etc.

Specificity

The last variable determines whether the knowledge is general or domain *specific*. In the case of fabrication, for example, the use of Vector Graphics is not specific to the field of laser cutting, but the mastery of its basics is necessary for the operation of the machine.

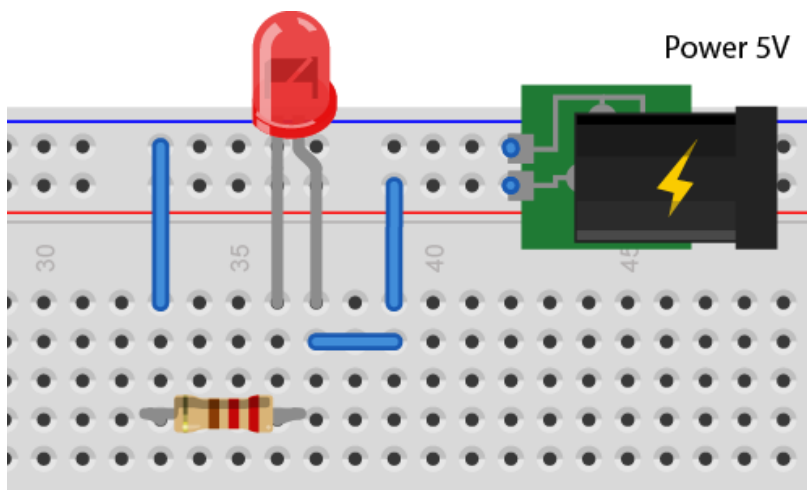

Figure 2.10.: Illustrations of our example

Let's now take an example in a fabrication context to analyse the different types of knowledge present and required to find an answer to a question. Figure 2.10 is a schematic representation of a simple electronic circuit, with the following question: what is the value of the current at the output of the led?

Conceptual:

There are several elements in this schematic: a breadboard, a led, two resistors, a power supply. The knowledge of these elements is important to understand their different properties.

Strategic:

Different courses of action can be chosen here to solve the problem: calculate the current with Ohm's law or build the circuit and measure the current with an ammeter.

Procedural:

If the second strategy is chosen, the procedure will be to first find the components, make the connections, turn on the circuit and measure the current with the measuring tool.

Situational:

The knowledge of the specific context informs about the way the components may function or not. For example, it requires situational knowledge to notice that a component looks like it is not properly put into the breadboard, or that it looks worn and possibly broken.

Modality:

The schematic also has different *modalities* of knowledge: visual, in schematic form, of different components, and textual concerning the voltage value of the power supply.

If an expert has no trouble finding the answer to the question quickly, the novice, faced with the same schema will be exposed to much more difficulties, because he will lack conceptual, strategic, procedural and situational knowledge. Furthermore, an expert will have no trouble understanding that Figure 2.10 is equivalent to the schemes in Figure 2.11a and Figure 2.11b.

This example is specific to the case of electronics, but it can be applied to a more complex fabrication project involving knowledge about different kinds of tools, materials and their properties and particular processes.

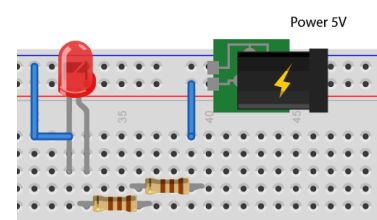

(a)

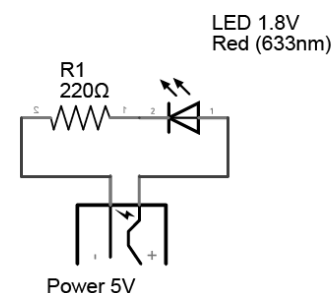

(b)

Figure 2.11.: Illustrations of our example

Understanding the way makers use different types of knowledge has an impact on the way it is represented. The inverse is also true since the way knowledge is represented has an impact on how makers understand a problem.

2.3.2. Knowledge resources in fabrication

Fabrication workshops are, as described in section 2.2, places of sharing [37], where makers learn, create, customise and invent, in short, create new knowledge. Thus, one of the parallel practices to fabrication is the transfer and sharing of knowledge.



Figure 2.12.: A view of the Sorbonne University's Fablab, structured as an open space

Knowledge exchanges can happen person to person in fabrication workshops. subsection 2.2.1 explained that their architecture is generally designed so that everyone has a view of the activity of others [8, 39, 125], and the communal culture of these places encourages curiosity, feedback and mutual aid [37, 61, 125, 130]. Figure 2.12 shows the prototyping space of the Fablab at Sorbonne Université, which is structured as an openspace. In these places, it is common for someone more experienced in a given practice to verbally demonstrate and explain a process or a principle to someone else. During group work, makers share what they have done or plan to do, and in the case of teaching or training, someone will demonstrate to a novice how to use a machine or software [35, 100]. If such

direct exchanges have the advantage of promoting a better understanding [61], another part of knowledge transfers are done indirectly, for a later reuse by oneself or by others in the form of knowledge resources.

Elements of knowledge

It is common in any practice to create content about one's work in the form of a note, an archive for oneself in order to remember a step, a parameter, or to draw a sketch. This is also the case in the context of fabrication workshops, where makers use a set of concepts and proceed to manipulations, which are important for them to keep in memory for the continuation of their work [151]. subsection 2.3.1 showed that this content can be of different *modalities*: it can be visual as makers create diagrams, record screenshots, take pictures and videos of a stage of construction or of the result of a process [102, 132]. These elements of knowledge can also take the form of parameters saved in the software, such as the speed, frequency and power of a laser for cutting and engraving a given material for instance, or CAD presets [49].

The element can also be physical, as in most of the workshops, managers or makers leave physical examples projects or samples which are displayed next to the machines with which it was made [8, 39]. As an example, Figure 2.13 shows a board with physical examples illustrating the percentage of filling density and the time the machine took to print the object. Figure 2.14 shows a shelf where 3D printed objects are displayed to serve as example of use of different techniques.

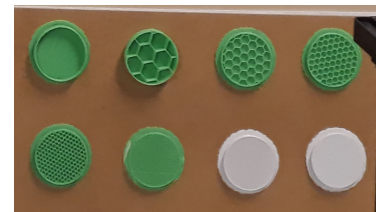

Figure 2.13.: Physical examples of the result for different values of filling density of 3D printed objects.



Figure 2.14.: Physical examples of 3D printed objects

These elements of knowledge focus on a very specific and concrete type of knowledge, such as which parameter settings to use with a certain material to get to a specific result.

Knowledge resources

Knowledge resources tend to combine elements of knowledge of different types (*procedural, strategic, ...*). The more different knowledge types are captured in the resources, the more likely someone will be able to fabricate a described artefact or to learn about various pitfalls when doing a certain type of activity. For this, some makers create and use knowledge resources in the form of digital documents that feature the evolution of the different stages of a project, including the materials and techniques used, and views of the result of the process.

Many works refer to these resources as *project documentations*, or *portfolios* depending on the context, but these terms are used in different ways in the literature, sometimes encompassing online instructions [91, 138], sometimes referring more to a working tool, allowing to keep track and serving as a reflection and communication support [13, 27, 135, 138], including mistakes made throughout the project, or not [138]. In that sense, their definition is sometimes close to the one of the *tutorial* or *how-to*, in which makers present their project in a linear step-by-step format, in a recipe style [132] for others to reproduce the project [112]. On the other hand, *tutorials* also seem to go beyond a simple list of instructions in some cases. Indeed, authors integrate the story of their project in a narrative style [132], sometimes with a humorous tone [67], sometimes including mistakes and problems encountered [132]. As an example, Figure 2.15 shows the introduction of an online *tutorial*, where the author explains the context in which she decided to build this project, and address herself directly to the reader.

Similarly to the variety of terminology they adopt, the reasons why makers create these knowledge resources are plural. Sometimes, documenting one's project is mandatory, while sometimes the motivation comes from the makers themselves. Indeed, some fabrication workshops encourage the creation of knowledge resources, in particular Fablabs, which include the creation of *project documentations* in their charter. The goal of these *documentations* is to allow others to reproduce any project that has been made with the workshop's resources [50]. In the context of learning, these documents are of particular

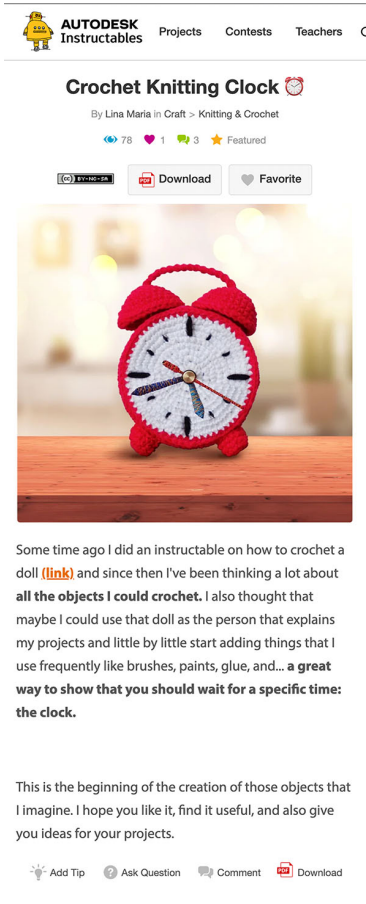

AUTODESK Instructables Projects Contests Teachers

Crochet Knitting Clock

By Lina Maria in Craft > Knitting & Crochet

78 1 3 Featured

Download Favorite



Some time ago I did an instructable on how to crochet a doll ([link](#)) and since then I've been thinking a lot about all the objects I could crochet. I also thought that maybe I could use that doll as the person that explains my projects and little by little start adding things that I use frequently like brushes, paints, glue, and... a great way to show that you should wait for a specific time: the clock.

This is the beginning of the creation of those objects that I imagine. I hope you like it, find it useful, and also give you ideas for your projects.

Add Tip Ask Question Comment Download

Figure 2.15.: Crochet Knitting Clock Instructables by Lina Maria - Introduction
<https://www.instructables.com/Crochet-Knitting-Clock/>

value. Peppler et al. [102] reported that most of educational makerspaces consider the practice of *documentation* and *portfolio* creation as important for them. These *documentations* can take the form of pictures of finished works or work in progress, videos, or documents that can be shared privately or globally on social networks or platforms dedicated to DIY practices.

The practice of creating knowledge resources is therefore often required by the environment where the makers work, however, some makers choose to share their knowledge on a voluntary basis. Indeed, building a knowledge resource can also be a mean to share one's project via the Internet in the form of *How-Tos* or *tutorials*, through personal blogs [132, 138, 141] or specialised websites. *Tutorials* or *how-to's* are used to explain a process, and in the case of fabrication activities, to replicate an object by detailing the steps, tools and materials needed to reproduce it. *Tutorials* take different forms, mainly web pages [77, 131, 132] and video tutorials [24], which can be hosted on *Youtube*. As an example, Figure 2.16 shows screenshots of a video tutorial made by the DIY video creator and musician "Look Mum No Computer". In his videos, he shows how to build electronic music instruments and DIY features, through his own eccentric style, mixing electronic music and super dynamic editing. If the latter proposes video tutorials in a remunerative optics, as a professional youtuber, in addition to some of these paying contents on *Patreon*, others have a completely altruistic approach. This is the case, for example, of the fine musician S8JFOU¹⁴ who creates his own synthesizers and provides, on his website, schematics, plans and explanations for building them, in a more sober but no less intimate way.

14: <https://www.s8jfou.com/synth>

Online platforms for sharing knowledge resources

Since the 2000s, many specialised websites around hands-on fabrication have appeared. Makers visit these platforms to find inspiration, or solutions to a specific issue they encounter [100, 115, 132].

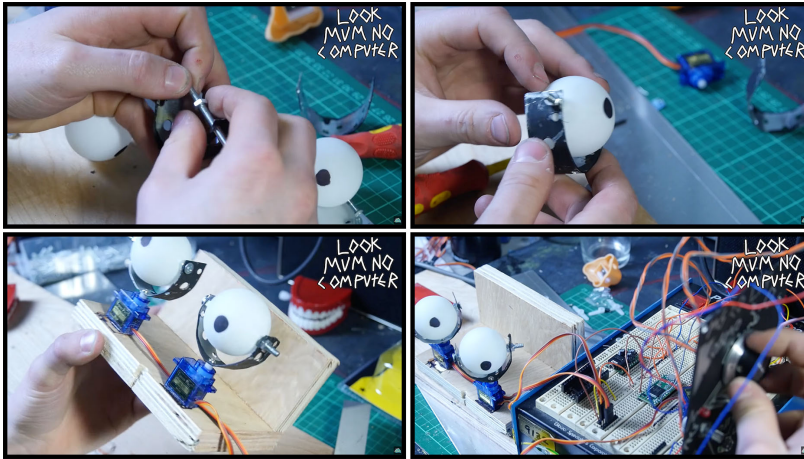

Figure 2.16.: This figure shows screenshots of a video of the DIY video creator and musician @LOOKMUMNOCOMPUTER, where he demonstrates how to build an animatronic controlled with the sounds generated by his synthesizer - <https://youtu.be/U5qHMgZJ2w4>.

Some platforms offer tools to create and host projects dedicated to the Do-It-Yourself universe as it is the case for *Instructables* [21, 77]. Figure 2.17 shows the list of steps of a tutorial hosted on this website.

Some online platforms are specialised around specific practices or communities [77], such as the *Arduino* website which offers to host projects created with the micro-controller, or the *Thingiverse* website which allows to host model files of three-dimensional objects intended for 3D printing or laser cutting accompanied by more or less complete descriptions [5]. These online platforms also serve as a support for exchange between the author of a project and the interested public [115], by the mean of comment features, as shown in Figure 2.17, thus allowing the creation of communities around these platforms [70, 100, 131].

The practice of knowledge resource creation is varied as much by the motivations of its author as by their format and style and by the audience that will use this knowledge resource.

2.4. Conclusion

This chapter introduced fabrication workshops through their history. Their evolution from a technological point of view is explained by the democratisation of computers throughout the second half of the 20th century. These advances have led to the automation of industrial machinery, the invention

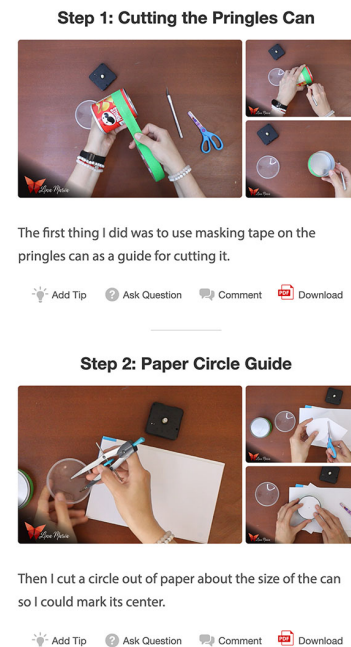

Figure 2.17.: Crochet Knitting Clock Instructables by Lina Maria - Steps

of additive manufacturing and the emergence of computer-aided design software, making the prototyping of objects accessible and fast. Fabrication workshops are associated with an ethic that also has its roots in the philosophy of the first hackers, eager to take power over new technologies. This unique culture of mutual aid, collaboration and sharing still persists today.

Most of today's workshops are open to all, welcoming a diverse and multidisciplinary audience, from designers to engineers and from experts to novices. These workshops are valued for the educational and social opportunities they provide by bringing together these diverse people in one place. Knowledge sharing is important in the context of fabrication, and the creation, use and sharing of knowledge resources related to the projects that can be done in the workshop is a common goal, whether in a learning setting or in a desire to return knowledge to the community.

However, introducing the richness of these workshops, and establishing the importance of creating knowledge resources in this context raises a question: what are the objectives behind these resources, and what are the barriers to which makers may be exposed while creating them? Depending on the context in which they are created and used and the variety of individuals who might create and use them, these objectives may vary. For example, the motivations for creating these resources can be intrinsic or extrinsic depending on the context, and the choices in the way they are presented vary according to the author's objective. Prior work has looked into the motivations and reasons for creating such resources and has identified main challenges regarding their creation. The aim of the next chapter is to take a closer look at the variety of objectives behind the creation of knowledge resources. In particular, I investigate the following questions:

- ▶ What are the different objectives of knowledge resources related to fabrication projects?
- ▶ What are the challenges that makers face when creating these resources?
- ▶ How may these objectives and challenges inform the design of tools to support makers in the creation of knowledge resources?

It is essential to understand the objectives of knowledge resources and associated barriers to provide systems and tools to help the creation, use and sharing of these resources.

Creating knowledge resources from fabrication activities

3.

Knowledge exchanges are prevalent inside and outside the fabrication workshop. I introduced in Chapter 2 different ways of creating and sharing knowledge resources. Between video tutorials and project documentation, I illustrated that the terminology, the forms of resources and the ways of creating them vary. Creating, using, and sharing knowledge resources related to fabrication is a common practice across different domains, and research on this topic is therefore scattered across different communities. Indeed, the terminologies used to describe these resources differ between communities, and the objectives and challenges associated with these resources are not always clear.

The aim of this chapter is, first, to clarify these different aspects of knowledge resources by understanding the different objectives behind them, and how these objectives may overlap. Second, I seek to identify the challenges that makers face when creating them, and whether these vary depending on their objectives. For instance, what are the difficulties of a maker wanting to create a tutorial from their project, and are they different from those of a student documenting their research throughout a study project? Finally, I discuss how these objectives and challenges inform the design of tools to support makers in the creation of knowledge resources.

This chapter is an extension of a work published in the IHM conference [106]. In this work, my co-authors and I conducted a literature review of 36 publications in HCI, education, and design addressing the topic of knowledge resources related to fabrication activities. Through this literature review, we identify four main objectives that these resources at least partially share. For each of these objectives, we identify a set of challenges from which we built a framework which

3.1	Methodology . . .	34
3.2	Objectives and Challenges in the creation of knowledge resources . .	38
3.3	Using the framework to analyse tools	45
3.4	Discussion	57
3.5	Conclusion	62

allows to contrast various strategies for resource creation. After presenting the framework, we use it to introduce and analyse different tools aimed to support makers with the challenges they face at different moments of the creation of knowledge resources. From this analysis, we highlight a set of strategies that support given challenges, and we discuss opportunities for the design of tools to support makers in the creation of knowledge resources in fabrication workshops. We will conclude with the common need for all resources to be created during the fabrication project and the necessary support during the fabrication activity.

3.1. Methodology

We describe the methodology used to identify the articles in our literature review and how we identified the objectives and challenges. Figure 3.1 provides an overview of the different steps of our methodology.

3.1.1. Definition of the search query

We started our research from a corpus of 21 articles collected organically, i.e. articles that we found during a regular reading activity, by following the references in articles that we consulted, or by consulting the program of recent conferences. We then extracted all the keywords of each of these articles, to identify on the one hand the recurrent keywords and on the other hand, the declinations of certain keyword roots (e.g. “maker” corresponds to the keywords “maker community”, “makerspace”, ...). We then classified these keywords according to whether they identify the *CONTEXT* (eg. makerspace) or the *SUPPORT* (eg. documentation). The query is built following the logic: $Keywords \subset AND(OR(x, x \in SUPPORT), OR(y, y \in CONTEXT))$, resulting in the following query:

*(“tutorial” OR “documentation” OR “documenting”
OR “knowledge sharing” OR “fabrication know-
ledge” OR “portfolio”)
AND
 (“maker education” OR “digital fabrication” OR*

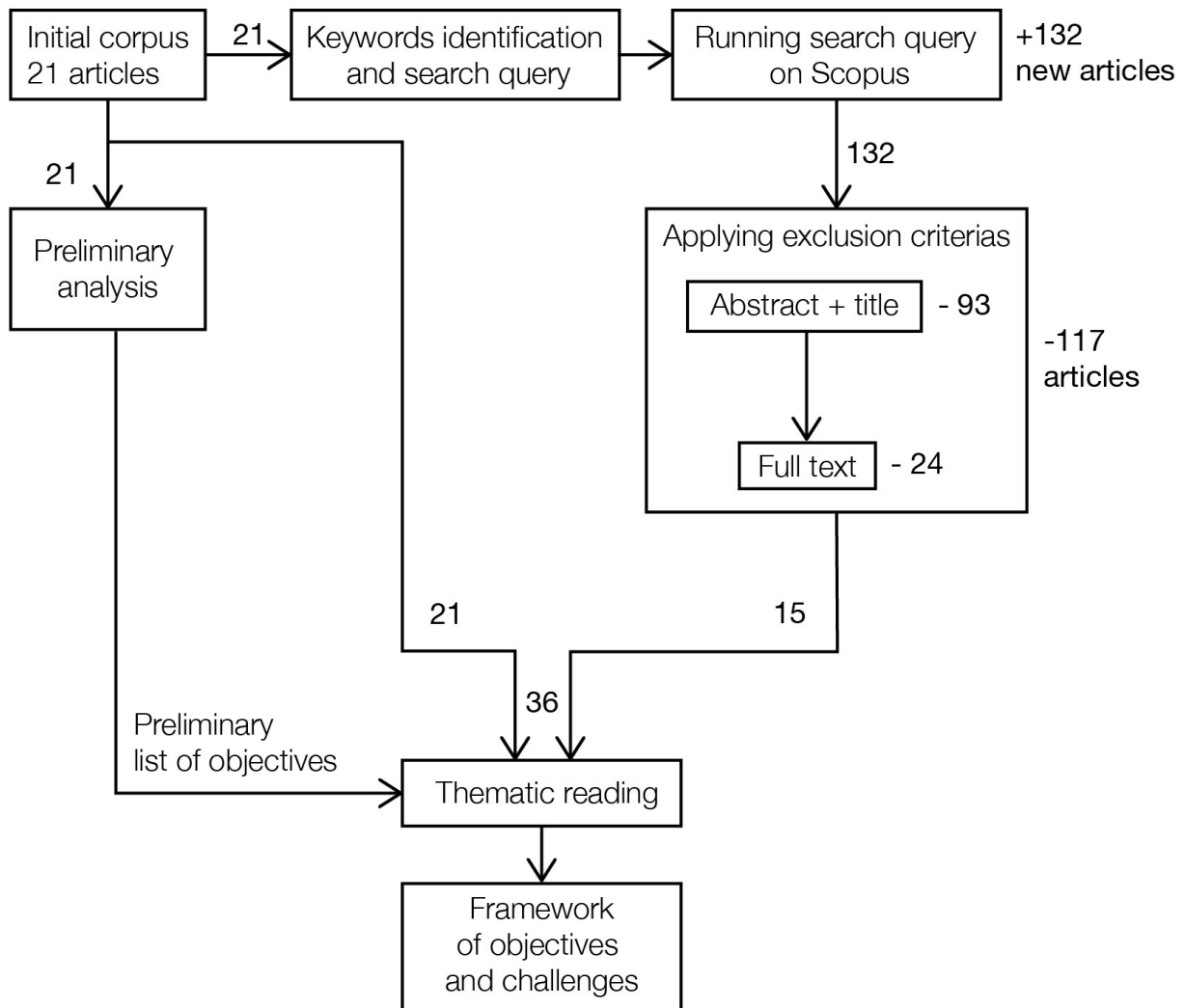

Figure 3.1.: Overview of the different steps we followed to gather and analyse articles and create a framework of objectives and challenges for knowledge resource creation in the context of fabrication workshops.

*"maker community" OR "maker communities" OR
 "making culture" OR "maker culture" OR "fablab"
 OR "fab lab" OR "fabrication laboratory" OR "fab-
 rication laboratories" OR "fab academy" OR "maker
 space" OR "makerspace")*

This query (also shown in Figure 3.2) was performed on Scopus¹ using Publish or Perish² on 25/08/2022. It returned 139 results, including 1 duplicate and 6 articles already present in our corpus of 21, that is to say 132 new articles.

1: <https://www.scopus.com/>

2: <https://harzing.com/resources/publish-or-perish>

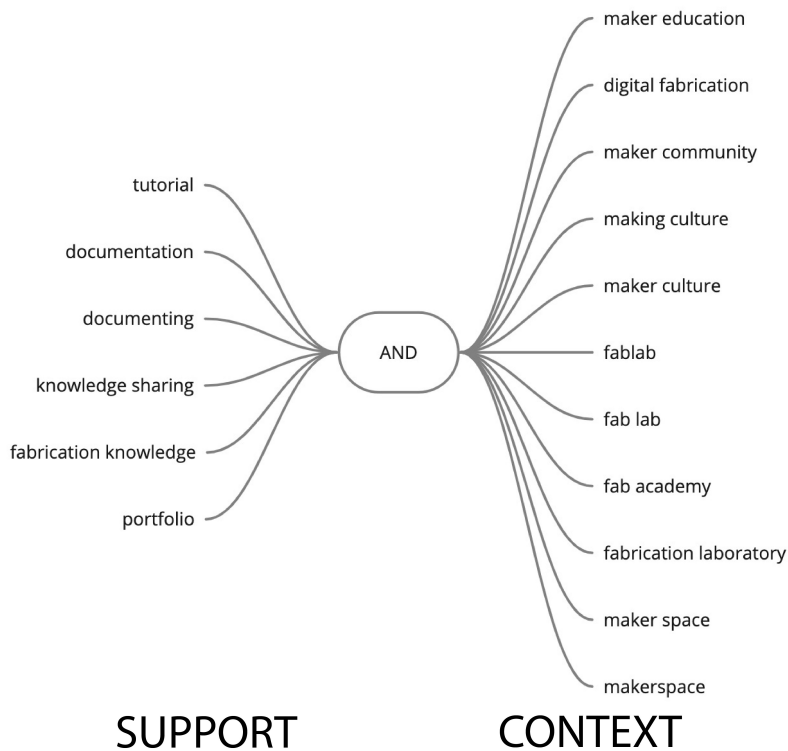

Figure 3.2.: Our search query includes all combinations of the terms support and context.

3.1.2. Exclusion criteria

An early analysis of the title and abstract allowed us to exclude articles that did not meet the following criteria:

- ▶ article written entirely in English (3)
- ▶ long scientific article from a peer-reviewed conference or journal (32)
- ▶ article in pdf format (0)
- ▶ article corresponding to the context of fabrication workshops, to DIY (29)
- ▶ article studying the topic of knowledge resources (22)
- ▶ article referring to a study or a tool preceded or followed by a study (10)

The number of excluded articles according to each criterion is in parentheses.

This initial analysis resulted in the elimination of 93 articles. We then eliminated 24 additional articles that the filtering based on the abstract was not sufficient to identify according to our criteria. For example, the abstract did not mention

Table 3.1.: Comparison of the 36 articles in our literature review for each objective and challenge in our framework. Note: Only the challenges explicitly specified in each article are marked with a square.

Objectives	Challenges	[85]	[24]	[45]	[138]	[91]	[32]	[56]	[27]	[121]	[132]	[25]	[39]	[151]	[77]	[150]	[144]	[61]	[84]	[70]	[67]	[38]	[94]	[65]	[54]	[11]	[96]	[135]	[68]	[71]	[82]	[115]	[16]	[20]	[139]	[131]	[101]		
Represent	Facilitate the creation of resources during the activity	■	■	■	■	■	■	■	■	■	■	■	■	■	■	■	■	■	■	■	■	■	■	■	■	■	■	■	■	■	■	■	■	■	■	■	■	■	
	Facilitate the creation of resources during the project	■	■	■	■	■	■	■	■	■	■	■	■	■	■	■	■	■	■	■	■	■	■	■	■	■	■	■	■	■	■	■	■	■	■	■	■	■	■
Reuse	Encourage the completeness of information	■	■	■	■	■	■	■	■	■	■	■	■	■	■	■	■	■	■	■	■	■	■	■	■	■	■	■	■	■	■	■	■	■	■	■	■	■	
	Encourage comprehensibility of information	■	■	■	■	■	■	■	■	■	■	■	■	■	■	■	■	■	■	■	■	■	■	■	■	■	■	■	■	■	■	■	■	■	■	■	■	■	■
Reflect	Reflect on one’s strategy and progress	■	■	■	■	■	■	■	■	■	■	■	■	■	■	■	■	■	■	■	■	■	■	■	■	■	■	■	■	■	■	■	■	■	■	■	■	■	
	Reflect together	■	■	■	■	■	■	■	■	■	■	■	■	■	■	■	■	■	■	■	■	■	■	■	■	■	■	■	■	■	■	■	■	■	■	■	■	■	■
Communicate	Express one’s knowledge and identity	■	■	■	■	■	■	■	■	■	■	■	■	■	■	■	■	■	■	■	■	■	■	■	■	■	■	■	■	■	■	■	■	■	■	■	■	■	■
	Belong to a community	■	■	■	■	■	■	■	■	■	■	■	■	■	■	■	■	■	■	■	■	■	■	■	■	■	■	■	■	■	■	■	■	■	■	■	■	■	■

clearly the context, or the presence of a study. In the end, our corpus contains 21 + 15 = 36 articles.

3.1.3. Corpus analysis strategy

To build our framework of objectives and challenges associated with knowledge resources, we proceeded in two steps. First, we conducted a screening of our initial corpus (21 articles) from which we defined a list of objectives related to knowledge resources. This first analysis then allowed us to carry out a thematic reading of the entire corpus (36 articles) to test and evaluate these objectives, and to identify challenges associated with each of these objectives. In the end, we consolidated our analysis into a framework of objectives and challenges with which each contribution can be described and compared, as shown in the Table 3.1.

3.1.4. Limitations

Some choices in our methodology introduced certain limitations. First, we wanted to collect a corpus representative of all the research fields addressing the subject of knowledge resources in fabrication workshops. We thus chose *Scopus*, which was the only database that did not restrict the number of characters of the query and which, because of its size, forced us to make a relatively closed query. Indeed, all the articles related to knowledge resources do not always specify *CONTEXT* in their keywords. Secondly, we wanted our query to be reproducible, and we therefore identified a set of the most frequent keywords. As a result of these choices, some

articles that could have been included in the corpus did not match this combination of keywords, as the terminological variety is rich. Nevertheless, this corpus has the advantage of being sufficiently varied to cover a wide range of research fields, which was our main criterion, and which allows us to identify a set of objectives from a rich field of problems.

3.2. Objectives and Challenges in the creation of knowledge resources

Our analysis revealed four objectives for knowledge resources in fabrication workshops: (1) **Represent a fabrication project**, (2) **Reuse one's work**, (3) **Support reflection**, and (4) **Communicate**. Depending on the context in which knowledge resources are created or used, only some of the objectives may apply. The Figure 3.3 illustrates how the objectives can overlap and provides examples of knowledge resources for which different objectives can be combined. We now present these 4 objectives and their corresponding challenges identified from our literature review.

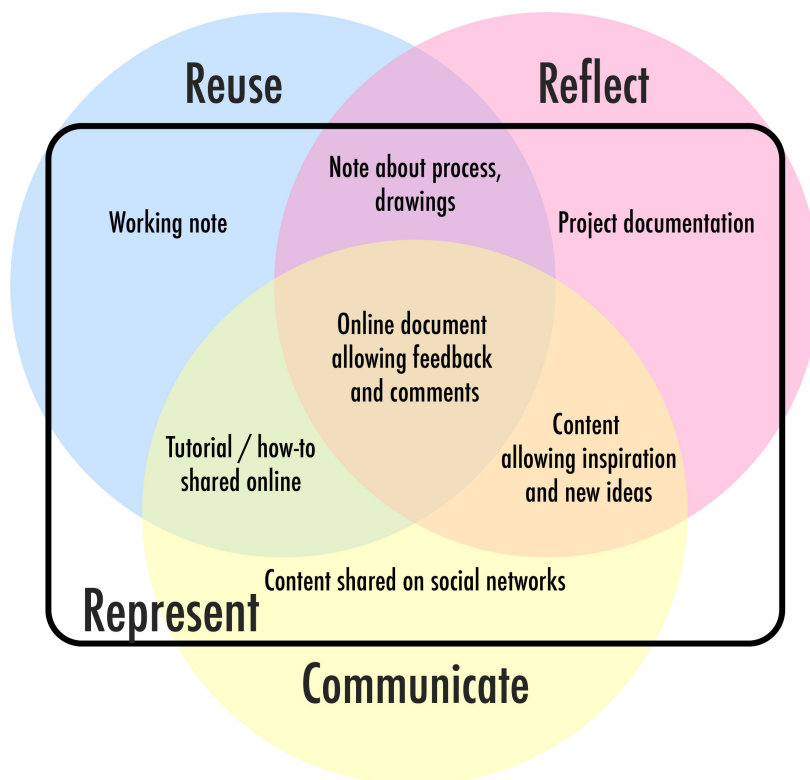

Figure 3.3.: The four identified objectives that makers can pursue when creating knowledge resources. **Represent** a fabrication project in some form is a transversal objective for all resources. More specific objectives are **Reuse**, **Reflect** and **Communicate**. The figure provides examples of resources for which objectives overlap differently.

3.2.1. Represent a fabrication project

Representing a fabrication project is an objective that is transversal to all knowledge resources. Indeed, despite other objectives they may pursue, all these resources represent a fabrication project, *i.e.* they are the result of the transformation of a set of physical and virtual interactions taking place in parallel with the fabrication project.

The fabrication project is composed of a sequence of activities that generally take place in several locations of the workshop and are spread over a more or less long period of time (days/-months) depending on its scope. Thus, generating knowledge resources exposes makers to different challenges: the first one is to create the resources during the fabrication activity; the second one is to create them during the whole duration of the fabrication project.

Facilitate the creation of resources during the activity.

During activities in the workshop, fabrication and the creation of knowledge resources are two conflicting activities [32, 138], both cognitively and physically. When makers work in the workshop, they generally devote most of their attention to the task at hand. Documenting this task therefore requires them to shift their attention from fabrication to documentation [56], a costly process that often leads to forgetting to document. These oversights are especially frequent during problems that require effort to solve [45, 85], or in the case of problems urgent to fix.

Both the fabrication and documentation tasks also require physical manipulation on the part of the makers, especially with their hands. For example, makers may want to take pictures or videos of a specific manipulation involving both hands. Sometimes, such manipulations make the capture of information impossible or require the use of additional tools, such as tripods or mounting systems [24, 91]. These tools may require additional effort and time from the maker, to find them in the workshop, and set them up. Carter et al. [24] observed that these tools themselves sometimes conflict with the activity (as in the case of tripods for example) by causing obstructions or limiting movements necessary to the

Fabrication project (subsection 2.2.1)

Fabrication projects can be described as a sequence of fabrication activities taking place inside the workshop, or outside the workshop, depending on whether they require the use of space or not.

manipulations. In addition, the necessary equipment is not always available or adapted to the needs of makers to easily take notes or capture visual traces [25]. It is therefore important to reduce the difficulties associated with the interference between documentation and fabrication, by making this task accessible and quick.

Facilitate the creation of resources during the project

In addition to the difficulties associated with physical and cognitive constraints during the activity, makers are exposed to other barriers during the entire course of their project: Once the content is captured, they may have to find it again among their files, choose the right illustration or file, which requires special organisation or effort [27, 85, 138].

In particular, Tseng and Resnick [138] reported in an interview study, that this process involves the use of many tools and platforms to host the content captured, to edit separately the images and the text and to assemble the whole in a final resources. In addition of the tools, transforming and editing the resources also requires specific skills to modify, process the content, and possibly pass it on to others [77, 91, 138, 150]. Communicating a process also requires the ability to describe and show ideas whose concepts are sometimes *automated* which are difficult to convey visually or textually [45, 132, 151].

Thus, creating knowledge resources is a difficult task for makers [39, 138, 151], and time-consuming [39, 56, 77, 121, 138, 151]. Some makers consider this task secondary, boring and unnecessary to the completion of their fabrication project [24, 151]. Therefore, its creation is often done at the end of the project [56, 121, 138], compromising some of the objectives we detail next (See Reuse (subsection 3.2.2) and Reflection (subsection 3.2.3)), or not done at all [151].

3.2.2. Reuse one's work

One objective of knowledge resources is that they are built to be reused by others. Other makers can use them as inspiration [27, 70] in their own work, as a reference for understanding

Automated knowledge (subsection 2.3.1)

Automated knowledge is close to the concept of explicit vs tacit knowledge. The more the person is expert, the more the processes guiding his methodology are automated and tacit. On the contrary, novices tend to follow step-by-step reasoning, more explicit.

the process or a particular technique [27, 41]. The knowledge resources can be used as a starting point in the project [27, 32], and as a guide to replicate a process [38]. In the learning context, teachers can use the resources as an evaluation tool, as they convey the rationale of the learners, their procedures and attempts [45, 85]. Enabling to reuse one's work implies building knowledge resources that are complete and comprehensible working tool for others. To be complete, the resources must contain the necessary amount of information, all the details and steps, and to be *comprehensible*, they must be of sufficient quality to be correctly interpreted.

Encourage the completeness of information.

To enable someone else to understand the described process, the resources must include the necessary amount of information in sufficient detail [91, 144]. Similarly to a recipe, all ingredients: tools, components, materials and references used must be specified [94, 132, 144]. However, getting the right level of detail is difficult for two main reasons. The first reason is that it is complex to anticipate what information will be used when creating resources; one must first establish what use will be made of it [27, 32, 41], which may vary from person to person and from context to context. The second reason is that the content needed to describe the process may not have been captured at the time of fabrication, because the person forgot [45, 84, 138], did not feel it was important at the time of the activity [32, 85], or the tools did not allow for it [24]. This lack of detail is intensified when the steps in the resources concern moments of bug, or abandoned or failed attempts [45, 85, 138]. If the amount of detail is sufficient, it sometimes happens that the frequency of the steps constituting the resources is insufficient and that all the steps are not well explained [45], making the understanding of the process difficult or not allowing to account for the actual reasoning of the author [121, 144]. It is indeed sometimes useful or necessary to know the intermediate, unsuccessful steps that led to a change of strategy in the process.

Encourage comprehensibility of information.

The understanding of a step by the persons who are reusing the resources is also impacted by the quality, clarity and consistency of the content describing the process [144]. Capturing visual content (image and video) plays an important role in how well the task is understood: the resolution must be sufficient and the lighting and point of view must be well adapted, which is sometimes not made possible by capture tools whose resolution is not sufficient or lacking in stability [24, 25, 91]. It also happens that elements are presented without context, that images or screenshots are not associated with a caption, or sometimes even that the texts associated with the images do not correspond [144].

3.2.3. Support reflection

When knowledge resources are built in parallel with the project, they become a support to see the progress of the fabrication project in real time. One of the reasons associated with the creation of knowledge resources is that they allow to keep track of the evolution of the fabrication project [11, 27, 39, 41, 45, 121, 135, 139, 151], allowing authors to refer to decisions made in the past [39, 135], either alone or with others.

Reflect on one's strategy and progress.

The knowledge resources can serve as a support for reflection during the activity [32, 54] and over the duration of the project, allowing for stepping back, considering the difficulties and problems encountered, the approaches and solutions found [20, 27, 32, 39, 68, 82, 91, 121, 139]. It also allows one to become aware of one's own progress [16, 27, 71, 121], and consider one's own practice [27, 115]. The creation of resources also helps to structure the stages of the project, to plan and organise future activities [16, 45, 68, 138, 151], coordinate with others involved in the project [27], and stay focused on the activity agenda [32, 138]. To enable the resources to support these reflections during the project, it is important

that the full range of steps and details are incorporated over time [16, 84, 121, 135, 138].

Reflect together.

During projects involving multiple people, the resources can serve as a medium for reflection and discussion [32, 56, 135, 151], allowing the author to present his or her ideas in order to get help during the project and feedback from teachers, peers or experts. It is important that resources can support these exchanges around projects, for example by providing co-located or remote discussion spaces, through which opinions and advice from other makers can induce some decision making by offering new perspectives [27, 70, 77, 131, 132, 135].

3.2.4. Communicate

The last objective associated with knowledge resources is to allow the makers to communicate and create an identity within a larger community by disseminating their work. Indeed, sharing one's work allows makers to communicate about their skills, to create an online identity, and to generate a community of people interested in the same things.

Express one's knowledge and identity.

Knowledge resources provide an account of the efforts, difficulties encountered, and techniques undertaken by a maker [27, 135]. They allow one to communicate the knowledge and techniques used and mastered [68, 70, 71, 91, 121], particularly necessary in a learning setting to attest to one's mastery. Communicating their knowledge also allows makers to express their identity and place in society, as a way to be recognised by their work, skills, and values [70, 71, 82], and allows them to tell their story through the project [101, 115, 135]. Thus, it is important for makers to be able to appropriate these knowledge resources so that they can be valued outside the workshop or teaching context [101].

Belong to a community.

Finally, the creation of knowledge resources can allow their author to integrate a community of people with the same passions, interests, practices [101], gathered around the same philosophy, culture of mutual help and sharing [131, 139, 150, 151]. The resources embody the DIY and hacker ethic (Chapter 2) with a willingness to help, build together, and make for others [20, 27, 38, 39, 70, 71, 82, 115]. By acting as a medium for discussion, the resources can be engaging, stimulate exchange around fabrication practices, inspire future projects [16, 70, 101]. Visitors can suggest improvements to the project [39, 70, 94, 101, 121, 132], ask questions or seek clarification from the author [77, 132]. Finally, the resources can be used to illustrate activities, tools, components, accessible in the workshop environment [20, 39, 68] and to share experiences between different workshops [16].

3.2.5. Conclusion

This section presented the results of our literature review to identify 4 objectives associated with the different knowledge resources produced by makers. Despite their variety, the reasons and the context in which they are made, these resources have one common objective:

- ▶ **Representing a fabrication project:** Whether they are looking to create a video, publish a tutorial on *Instructable*, or feed their portfolio as part of a teaching assignment, makers are exposed to common processes. They must collect content during their fabrication activity and create a document from the different steps of their projects.

We also identified 3 other objectives that knowledge resources enable:

- ▶ **Reuse one's work:** The resources can help others to understand the procedures and strategies used by the author, so they can reproduce the project, or assess the rationale and expertise of the maker.

Variety in knowledge resources (subsection 2.3.2)

We saw in Chapter 2 examples of variety of knowledge resources that makers may create from their projects.

- ▶ **Support reflection:** The resources can be used a tool to follow the progress of a project, keep track of important steps, work and coordinate with collaborators.
- ▶ **Communicate:** The resources can be a way to disseminate one's work and identity over the Internet, exchange with others and feel recognised by a community outside of the local place.

From these objectives we identified 8 challenges associated with the creation of knowledge resources. In the next section, we will demonstrate how to use our framework as a mean to describe different tools for the creation of knowledge resources, and highlight strategies used by these tools to support makers for their objectives and given challenges.

3.3. Using the framework to analyse tools

In this section, we present a selection of tools supporting makers in the creation of knowledge resources that we found in the literature. First, we demonstrate how to use our framework to describe these tools based on the objectives and challenges they support. Then, we show how our framework can highlight the different strategies of these tools to support each of these challenges. Table 3.2 illustrates how our framework describes each tool when looking at its columns, and which of the challenges are supported by a given tool, when looking at its lines.

3.3.1. Tools to support makers in the creation of knowledge resources

Knowledge resource creation involves the use of various tools to capture, edit and share knowledge [138], and most workshops are not equipped with dedicated tools to facilitate the creation of these resources [102]. However, past research has proposed a variety of tools to support makers facing the challenges that we described in section 3.2. To demonstrate how to use our framework as a descriptive instrument, we made

a selection of 8 tools from literature that we chose for the variety of objectives and challenges they aim to support. For example, some are made to build tutorials, while others are made for an educational purpose.

We now describe these 8 tools using our framework of objectives and challenges. We distinguish software solutions and hardware solutions. The Software solutions focus on supporting makers during the transformation and representation of the knowledge resources. Hardware solutions also provide means to capture content for the resources. Hardware solutions are more numerous, thus we divide them into two categories: fixed tools (documentation station) vs mobile tools (wearable tools).

Software solutions

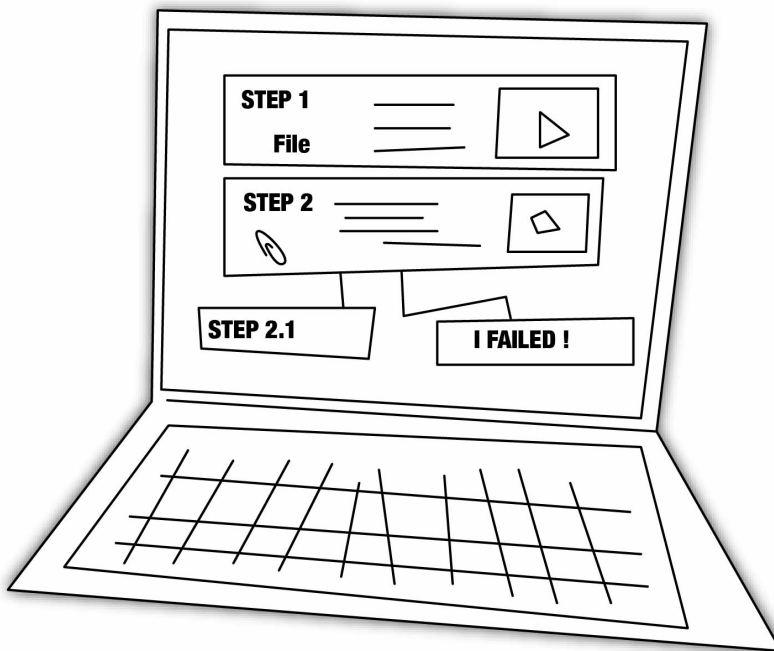
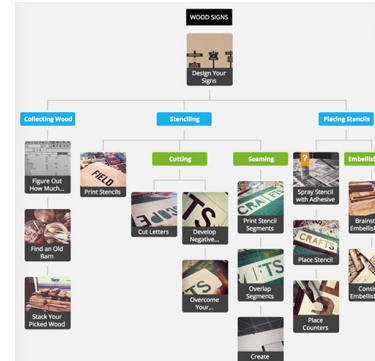

Figure 3.4.: Software solutions enable makers to edit and transform the knowledge resources

Build-In-Progress (BiP) [135]

Build-In-Progress (BiP) is an online application built to publish the steps of an ongoing project, to keep track of the process and to get feedback as the project progresses. The steps are made of images, videos and text, and can be organised in a tree, in order to visualise the whole project including unsuccessful or abandoned attempts (Figure 3.4). Thus, BiP facilitates the creation of resources during the project, helps to reflect on one's strategy and progress and reflect together. The tool is available online and visitors can comment on others projects, give or get help from the community. The site (which is no longer accessible today) allowed the makers to belong to a community of the users of BiP.



Project Reflection Tool (PRT) [32]

Project Reflection Tool (PRT) is a web-based platform created for designers, shared among several collaborators and allowing a visualisation of the progress of a project over time. It is based on a set of pre-structured elements including Events, Sub-events, and Notes that designers can create as the project progresses. The resources are thus structured and can be visualised both in the form of a timeline and in the form of web pages. PRT is specifically designed to reflect on one's strategy and progress and reflect together on collaborative projects, it facilitates the creation of resources during the project by simplifying the process thanks to a pre-designed format and structure, and by offering a direct visualisation of the resources.

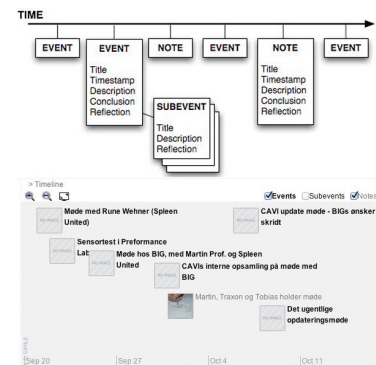

Hardware solutions (Fixed)

One strategy is the use of documentation stations (Figure 3.5). It consists of installing interfaces inside the workshop to support the makers in the creation of knowledge resources. These documentation stations, are generally at least equipped with cameras to capture images and videos of an object or a prototype [72]. The presence of these stations aims to reinforce the propensity to think about documenting and help providing

nice angles to capture visual project traces, while freeing the hands of the makers [72]. Different tools in the literature are based on this strategy of stations:

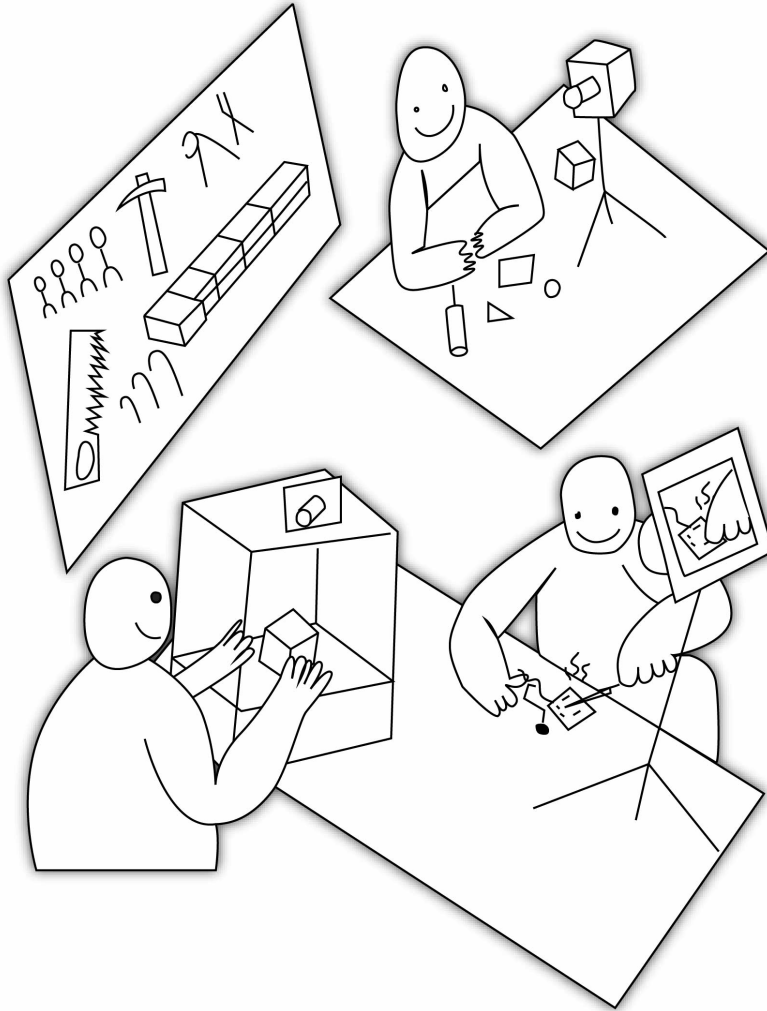
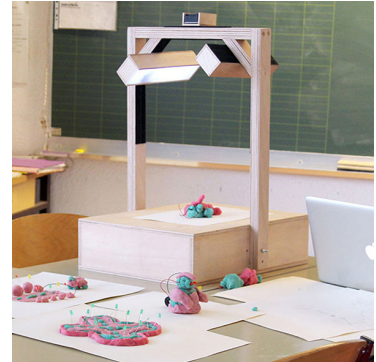

Figure 3.5.: Some workshops provide fixed stations to capture content from fabrication activities.

DoDoc [55]

DoDoc is a tool intended for an educational setting to capture images, videos, and sound. This tool is modular and adaptable to *facilitate the creation of resources during the activity*. Cameras and lights can be attached at different positions and a remote controller allows the trigger of the capture. The interface is associated with a web application on which the content is automatically uploaded, thus *facilitating the creation of resources during the project*. This application allows in particular the direct visualisation of the captured content, with the aim to allow to *reflect on one's strategy and progress* during the fabrication activity.

*Protoboost Oulu [11]*

In a similar way, Protoboost Oulu is a station that includes multiple cameras to capture different points of views of an object. Makers can use a RFID card to easily trigger the capture of pictures from the station, *facilitating the creation of resources during the activity*. The content is automatically uploaded to a website as entries that makers can edit later on, therefore the tool also *facilitates the creation of resources during the project*. This tool was also designed for educational use, within the Oulu Fablab, and allows for easy capture and creation throughout the project by making the content accessible to makers and allow them to *reflect on one's strategy and progress*. The authors also highlight the ease of sharing the content captured by Protoboost Oulu from the website interface to allow makers to *reflect together and communicate*.

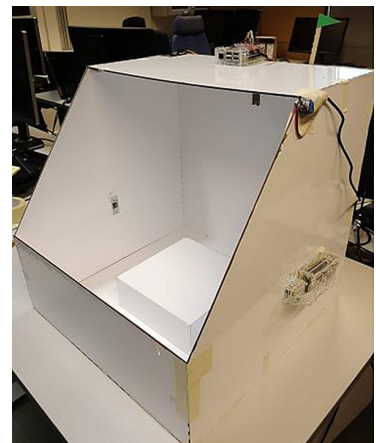

FabNavi [140]

Another tool of our selection is FabNavi. Unlike the two previous ones which rather focus on reflection, this station creates visual instructions for assembly process, resources allowing to *reuse one's work*. The station is based on a camera located on top of a desk, and a projector. During an assembly activity, the makers can take top view photos of the different steps they are working on, and the steps can then be projected back onto the desk. The application saves a series of steps as top view images, and are shared with others so makers can reproduce these steps remotely.

*Spin* [139]

Finally, Spin is an interface based on an actuated turntable, which allows makers to take 360-degrees animations of an object. The aim of this platform is to document the states of a project at the end of work sessions, as to show its evolution through time. The turntable is connected to a mobile application to trigger the capture of the 360-degrees animation. Spin also comes with a web application to visualise the different animations created through time, and allows makers to *communicate* by sharing these animations on social networks such as Twitter and Facebook.

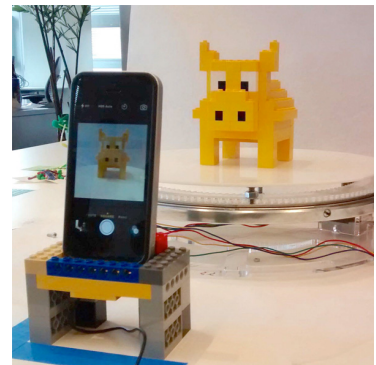
**Hardware solutions (Mobile)**

A different strategy to documentation stations is to equip makers with devices that facilitate capture during fabrication activities (Figure 3.6). These devices have the advantage, unlike the stations, of allowing the mobility of users.

One strategy is the use of smartphones which most makers are already equipped with.

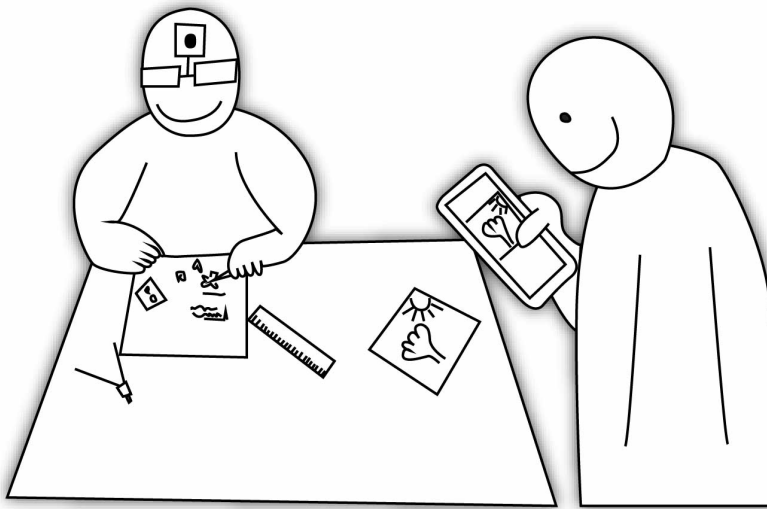

Figure 3.6.: Some workshops provide mobile devices to capture content from fabrication activities.

Document-While-Doing (DwD) [91]

Document-While-Doing is a mobile application to take pictures and record sound annotations that end up in a project repository. Each project is associated with a web-page automatically generated, similarly to Protobooth Oulu [11]. Furthermore, the application features an option to automatically reduce the size of the images to be included in the web-page.

However an approach based on smartphones requires the makers to hold them, limiting manipulations with the hands. An alternative is to use head-mounted capture tools:

ShowHow [25]

ShowHow captures images and videos directly from Google Glasses or a tablet, facilitating the manipulation of objects with the hands, while transferring the captured content directly to an editing interface, thus allowing both to *facilitate the creation of resources during the activity and during the project*. By enabling first-person perspective capture, and supporting tutorial formatting with annotations and file attachments, ShowHow also both *encourages the completeness of information and comprehensibility of information*.

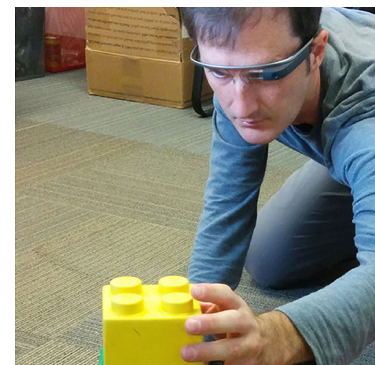
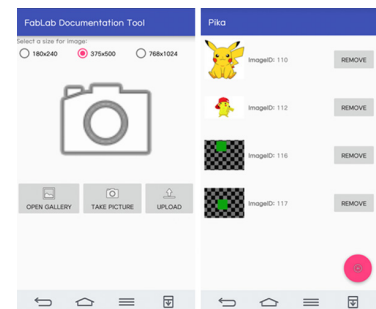

Table 3.2.: Analysis of tools through the framework of objectives and challenges

Objectives	Challenges	DoDoc [55]	Protobooth [11]	FabNavi [140]	Spin [139]	DWD [91]	ShowHow [25]	BiP [135]	PRT [32]
Represent	Facilitate the creation of resources during the activity	■	■	■	■	■	■	■	■
	Facilitate the creation of resources during the project	■	■	■	■	■	■	■	■
Reuse	Encourage the completeness of information			■			■		
	Encourage comprehensibility of information			■			■		
Reflect	Reflect on one’s strategy and progress	■	■	■	■	■	■	■	■
	Reflect together		■		■		■	■	■
Communicate	Express one’s knowledge and identity		■		■				
	Belong to a community				■			■	

3.3.2. Strategies to support the 4 objectives

We selected a total of 8 tools highlighting the objectives and challenges that each one aims to address. Our framework also enables to highlight the different strategies of these tools used for each objective by looking at each row of the table 3.2. We now discuss these tools by objective to identify different strategies to support the challenges associated with a given objective.

Represent a fabrication project:

Challenges	DoDoc [55]	Protobooth [11]	FabNavi [140]	Spin [139]	DWD [91]	ShowHow [25]	BiP [135]	PRT [32]
Facilitate the creation of resources during the activity	■	■	■	■	■	■	■	■
Facilitate the creation of resources during the project	■	■	■	■	■	■	■	■

Strategies: Facilitate creation during the project

- ▶ Providing features to support the edition and process of the content captured
- ▶ Automating part of the creation (pregenerate, transfer, content processing)

First, we observe that despite their variety, all of these tools address the transversal objective: “*Represent a fabrication project*”, particularly the challenge “*Facilitate the creation of resources during the project*”. Indeed, they have in common to simplify certain stages necessary to create a representation of knowledge resources from the content captured by the makers.

To support makers during the transformation steps following the capture of content from fabrication, one strategy is to **provide features to support the edition and process of the content captured** toward complete knowledge resources. These resources can be in the form of a document or a web page in the case of PRT, ShowHow, Protobooth Oulu, and DwD. They also can take the form of trees representing the steps through time as in the case of Spin, PRT, FabNavi and BiP, and videos or animations in the case of ShowHow and Spin.

Another strategy is to **automate part of the creation** as done by DwD and Protobooth Oulu which automatically generate a web Page featuring the content captured, that makers can enrich later on. DwD also integrates a tool to automatically reduce the size of images aimed to be included in the final resources. Some of these tools also facilitate the step of transfer of content, by sending the captured content directly to a centralised space. This retrieval and transfer step is a considerable cost for makers [138] and automating it is a time and effort saver.

As a way to *facilitate the creation of resources during the activity*, we saw that most of our selected tools **incorporate a capture device**. These tools allow the capture of images and videos from different angles, through a modular interface in the case of DoDoc, tabletop camera in the case of FabNavi, multiple cameras in the case of Protobooth Oulu, 360-degrees views in the case of Spin, and Google glasses in the case of ShowHow. Providing makers with equipment at hand to capture content is a good way to support this challenge and has the advantage of **freeing the hands** of the makers during manipulations, one of the first difficulties during the fabrication activity.

Strategies: Facilitate creation during the activity

- ▶ Providing capture tools inside the workshop
- ▶ Enabling hand-free control

Reuse one’s work:

Challenges	DoDoc [55]	Protobooth [11]	FabNavi [140]	Spin [139]	DwD [91]	ShowHow [25]	BiP [135]	PRT [32]
Encourage the completeness of information	■							
Encourage comprehensibility of information	■							

Two tools of our selection address the objective *Reuse one's work*: ShowHow [25] and FabNavi [140]. They have in common to create tutorials so that others can reproduce the project. As such, their strategy to *encourage the comprehensibility of information*, is to **acquire good quality visual content**. They differ in the sense that ShowHow allows that by capturing content from a first person perspective, while FabNavi takes a series of top views, **providing the steps in an homogeneous way**.

Both their strategy is to **make the capture easy and at hand** so the makers are less inclined to miss a step of the procedure. Therefore, they *encourages completeness of information* by contributing to a greater frequency in the captured steps. ShowHow also allows makers to **add annotations, links and attachments to the resources** in its editing interface.

Support reflection:

Challenges	DoDoc [55]	Protobooth [11]	FabNavi [140]	Spin [139]	DwD [91]	ShowHow [25]	BiP [135]	PRT [32]
Reflect on one's strategy and progress	■	■	■	■	■	■	■	■
Reflect together		■		■		■	■	■

Six of the tools in our selection are designed to support the reflection of makers by keeping traces of the process. To do that, the strategy of PRT and BiP is to allow the maker to create a **representation in the form of a tree** of the various paths taken during the project, which is made available to other participants, locally in the case of PRT and via the internet in the case of BiP. This strategy allows to make visible the paths that may not have been successful, in order to enable makers to keep track of what did not work. DwD and Protobooth Oulu adopt a more **classic web based representation** of the content captured, while Spin simplifies the format to a **simple animation**, making it easy to generate resources at the end of each fabrication activity. DoDoc takes a different approach to allow makers to *reflect on one's strategy and progress* and encourages reflection during the fabrication activity

Strategies: Encourage the comprehensibility of information

- ▶ Enabling the capture of good quality content and homogeneous content

Strategies: Encourage the completeness of information

- ▶ Providing equipment at hand to maximise the frequency with which content is captured
- ▶ Providing editing features to support the addition of annotations and file attachments

Reflect on one's strategy and progress

- ▶ Considering different representations (tree, web page, 360 degrees animations)
- ▶ Providing direct access of the captured content

by **providing a direct access of the content captured** by displaying it on screen right next to the station.

To *Reflect together*, the web based strategies adopted by PRT, BiP, DwD and Protobooth Oulu allow to generate discussions and get feedback on the work as the project progresses by the means of **comment sections**.

Communicate:

Challenges	DoDoc [55]	Protobooth [11]	FabNavi [140]	Spin [139]	DwD [91]	ShowHow [25]	BiP [135]	PRT [32]
Express one's knowledge and identity	■	■						
Belong to a community			■				■	

One way to allow makers to communicate with their knowledge resources, is to make them available on the Internet. This is the case of Protobooth Oulu, DwD and BiP which provide an online platform to host the resources and Spin which enables to share content on social networks. Because of the web page format, Protobooth Oulu and DwD **provide space for makers to add narratives** to the resources and therefore to *express one's knowledge and identity*. However, the content is still hosted on the Fablab's website, limiting the opportunity to *belong to a community*, unless the website is particularly popular. On the opposite side, Spin allows for **direct sharing on social networks, favouring the appropriation of the resources by the makers**, but does not provide room for narrative. Similarly, BiP allowed the makers to *belong to a community* by providing a **space for comments and feedback**, but this community was made up only of users of BiP.

3.3.3. Conclusion

In this section, we have adopted the framework introduced in section 3.2 to show how it can be used to analyse tools for the creation of knowledge resources.

Reflect together

- ▶ Providing comment sections on the different steps of the resources to get feedback during the advancement

Express one's knowledge and identity

- ▶ Providing space for the maker's narrative
- ▶ Enabling appropriation of the resources by the maker

Belong to a community

- ▶ Enabling the resources to be shared on larger community platforms
- ▶ Enabling community discussions and feedback

Table 3.3.: Summary of the strategies used by our selection of tools to support the creation of knowledge resources.

<p><i>Represent</i></p> <p><i>Facilitate creation during the activity</i></p> <ul style="list-style-type: none"> Providing capture tools inside the workshop Enabling hand-free control <p><i>Facilitate creation during the project</i></p> <ul style="list-style-type: none"> Providing features to support the edition and process of the content captured Automating part of the creation (pregenerate, transfer, content processing) 	<p><i>Reuse</i></p> <p><i>Encourage the comprehensibility of information</i></p> <ul style="list-style-type: none"> Enabling the capture of good quality content and homogeneous content <p><i>Encourage the completeness of information</i></p> <ul style="list-style-type: none"> Providing equipment at hand to maximise the frequency with which content is captured Providing editing features to support the addition of annotations and file attachments
<p><i>Reflect</i></p> <p><i>Reflect on one's strategy and progress</i></p> <ul style="list-style-type: none"> Considering different representations (tree, web page, 360 degrees animations) Providing direct access of the captured content <p><i>Reflect together</i></p> <ul style="list-style-type: none"> Providing comment sections on the different steps of the resources to get feedback during the advancement 	<p><i>Communicate</i></p> <p><i>Express one's knowledge and identity</i></p> <ul style="list-style-type: none"> Providing space for the maker's narrative Enabling appropriation of the resources by the maker <p><i>Belong to a community</i></p> <ul style="list-style-type: none"> Enabling the resources to be shared on larger community platforms Enabling community discussions and feedback

Then, we used our framework to highlight the strategies of each of these tools to support a given challenge. This second analysis allows us to establish a list of strategies used by these tools for a given challenge which we summarise in Table 3.3.

This list of identified strategies is not intended to be exhaustive as it is drawn from a selection of tools of our choice. Establishing a complete list of existing strategies to support makers facing given challenges is a research direction to explore, which we discuss in the Chapter 6. However, highlighting this sample of strategies already allows us to outline some avenues of reflection.

In the next section, we discuss these different strategies and establish some research directions around the design of tools to support the creation of knowledge resources.

3.4. Discussion

We have highlighted some strategies to support makers in the creation of knowledge resources. What emerges is that these different strategies focus on one of the four steps of resource creation: capture, transformation, representation and dissemination of the resources.

Many strategies focus on the challenges present in the first two steps:

- ▶ content **capture**, which takes place in the fabrication space during the activity, essentially based on hardware technologies,
- ▶ content **transformation**, which is integrated in parallel with the fabrication project, and based on software technologies.

Indeed, these are the two steps requiring the most effort from the makers, and being transversal to all resources.

The rest of the strategies consist in supporting the challenges related to the more specific objectives which happen during the representation and dissemination steps:

- ▶ the **representation** of the resources, which can take different formats, and provide interactive features such as comment sections,
- ▶ the **dissemination** of the resources, which can be held locally, or shared on the Internet.

In this section, we aim to guide the conception of new tools. We discuss different implications that emerge from our analysis of both the tools and our literature review around these moments in the life of the resources. We first discuss implications for capture and transformation to establish directions for supporting the most challenges. Second, we discuss the different needs related to the representation and dissemination of the resources, which motivate a need for interoperability between tools.

3.4.1. Capturing and transforming the resources

We have seen that many of the challenges are related to the fact that it is difficult to create the resources during the fabrication activities, and over the course of the project. Indeed, it is necessary to (1) *Encourage the completeness of information* (subsection 3.2.2) and to avoid oversights, and for (2) *Support reflection* (subsection 3.2.3) as a means of taking a step back from the work in progress. Therefore, the strategies used by the different tools are sometimes similar and focus on making resource creation easier for makers, both during the activity (the capture of content) and over the duration of the project (the transformation of content).

Capturing content

Several strategies that we have highlighted consist in supporting the makers by providing them with capture tools to *facilitate the creation during their fabrication activity*. Most of them allow to **free the hands of the makers**, which is an essential obstacle to the creation of knowledge resources. The **availability of tools in the workshop** also seems to have the advantage of maximising the frequency with which content is captured by users, avoid them to forget important steps, and therefore *favour the completeness of the information*. Common capture tools can also be used to capture content of **good quality**, and in a **homogeneous** way, facilitating the *comprehensibility of the information*.

We have seen that these solutions can consist of equipping the workshop with documentation stations, or providing the makers with wearable capture devices. Stations have the advantage to materialise in space, the time for the creation of resources. They also make it possible to “celebrate design moments” by generating exchanges between the makers around the tool [54] and thus to *Support reflection*. However, these stations do not allow to follow the makers in their movements in the workshop. This can be achieved by providing the maker with wearable capture devices.

The main challenge is to determine a good compromise between integrating the tools into a person's workflow, maintaining high visibility to serve as a frequent reminder, while not impeding the activities of the makers.

Transforming content

All the tools of our selection facilitate the creation of the resources by **integrating editing and content processing features**. This is indeed one of the common strategies to *facilitate the creation of resources during the project*. Some of these tools adopt editing features allowing the addition of external files, links, to promote the *completeness of the information*. Others allow a space for the author's narrative, important to *express his identity*. Providing an interface to transform the content is an essential strategy to support makers during the transformation of the resources as this step requires the use of many tools [138].

Another way to make resource creation easier is to delegate some of the creating process to other people [32], create group documentations [71] or **automate part of the process**. The latter is, for example, the case with some of the tools we presented, which automate the transfer of captured content to the editing interface. Others also automate the processing of the captured content as is the case with Document-While-Doing [91] which reduces the resolution of images before automatically integrating them into the documentation. Some tools automatically generate entire resources as in Protoboost Oulu [11], Spin [139] and PRT [32]. We study the potential benefits and drawback of automation in chapters Chapter 5 and Chapter 6.

3.4.2. Representing and disseminating the resources

Our analysis shows that all the tools presented offer a complete solution to support some challenges of knowledge resource creation. In addition to editing features, all the tools in our selection offer support for the final representation of the resources, which most of them provide in a given format

and constrain the resources to the tool itself. We also noticed that few of the tools focus on strategies regarding the dissemination of the knowledge resources. We discuss now the necessity for the tools to enable different representations of the resources, and how important it might be for these tools to provide more opportunities for dissemination.

Representing the resources

The way knowledge resources are **represented**, (video, image, structured document, ...) is central to the objectives that these resources supports, as they allow information to be conveyed in a certain way by imposing a particular structure [45, 96]. Thus, one of the strategies we observe is the constraint of the format of the resources to incite the makers to create resources according to certain codes or approaches. For example, the imposed format can be a linear step-by-step structure like the tutorial, or more tree-like, it can contain videos, sounds, links to external resources. The creation of the resources can also be framed by a particular methodology that supervisors or teachers can impose on the makers [45, 85], favouring the place of reflection, the details of the process, or the reproducibility. Oliver et al. [96] suggest for instance that the video format is better suited to describe experiences in an informal, emotional, and descriptive manner while writing allows for the development of analytical sides in a more academic and detailed manner [96].

Constraining the format can also make it possible to create the resources over the course of the project, as shown by the example of Spin [139] which by the simplicity of its format in the form of an animation at the end of each activity, encourages generating a record of the artefact's evolution over its entirety. However, a simple animation does not contain enough detail to allow for replication of the project.

In addition to the format, we saw that some of the tools provide **interactive features such as comment sections** to provide feedback from peers or teachers during the course of the project to *support reflection*, and as mean to *communicate* with a larger community at the end of the project.

Constraining the format and providing space for exchanges as been explored to guide and help makers towards a given objective, however, makers may want to pursue several objectives, and if a tool doesn't allow to generate different representations, it should therefore be interoperable with other tools to generate such representations.

Disseminating the resources

Few strategies from our selection of tools address the aspect of dissemination of the resources. In particular, we have found that few works address the challenges of appropriating the resources and sharing them with a larger community, which is necessary for the objective “*Communicate*”. This is partially due to the fact that systems allowing the creation of knowledge resources allow access to these resources only through this system. These resources are then difficult to reuse with existing online platforms [20] such as *Instructables* for instance. Yet, Pepler and Keune and Keune, Pepler and Dahn indicate that **sharing the resources** could be an incentive for makers to create these resources [71, 101] and appropriate it to include other, more personal or social types of thinking [71]. Promoting **appropriation** of resources by makers so they can chose there own representation, add personal narratives and customise it, is therefore important for them to make the most of it individually. They should be able to benefit from the tool to create a representation of resources that could be customised, and shared under other formats and toward other communities than the local environment. For instance, the tool should allow the resources to be shared on specialised (*Instructables*, *Thingiverse*, ...) or non-specialised (*Instagram*, *TikTok*,...) sharing platforms.

3.4.3. Conclusion

In this section, we have discussed the different strategies employed by our selection of tools. These strategies are only from a selection of tools and are probably not exhaustive, but they have nevertheless allowed us to show some trends guiding the design of tools for knowledge resource creation.

We have seen that these strategies concern one of the four stages of the life of the resources: capture - transformation - representation - dissemination.

First, we have seen that the capture step is crucial, and that it is important to facilitate capturing knowledge as base material for the creation of knowledge resources to makers in a fabrication workshop. These tools must allow to capture good quality content, and allow the manipulation of objects with the hands. We explore the capture of this content in more detail in the rest of this thesis, Chapter 4 and Chapter 5.

Secondly, we found that some of the tools explore the automation of part of the resource transformation, this strategy deserves to be further explored. We explore some aspects of automating content capture in Chapter 4 and Chapter 5, and we discuss other aspects of automating knowledge resource creation in Chapter 6.

Finally, we found a need for the tools to be interoperable in order to allow the generation of different types of representations, and to allow the dissemination of resources outside the tool itself.

3.5. Conclusion

In this chapter, we conducted a literature review from which we identified the objectives and challenges for knowledge resource creation, which led us to guidelines regarding the design of tools to support makers facing these challenges.

This work is important because it can allow to emphasise different things. First of all, we have noted in the Chapter 2, the growing variety of users of fabrication workshops, as well as the different contexts in which makers are brought to produce knowledge. We also noted in Chapter 2 this porosity between the terminologies used to describe knowledge resources: tutorials, portfolios, project documentation. Thus, this chapter has taken into account these different terminologies gathered under the term "knowledge resources". The work presented

allows us to clarify the different objectives that these knowledge resources can pursue: Represent a fabrication project - Reuse one's work - Support reflection - Communicate.

Second, we have identified more precisely the challenges faced by makers pursuing a given objective in the creation of their resources. Identifying these challenges by objective allowed us to see that many of the proposed tools focus on one part of the makers' challenges. That while many of the proposed tools are complete solutions including capturing and editing, they tend to focus on only one or two objectives and specific challenges. On the other hand, a tool that addresses all objectives and challenges risks being feature-bloat making it adapted to no one in particular and difficult to use for most. However, one could imagine that a tool made available to the community of makers of a workshop could allow these makers to pursue a variety of objectives, and thus be helped in any challenges they face.

In addition, we have highlighted the strategies used by a selection of tools to guide the design of future tools, thinking in terms of the objectives and challenges of the makers. These strategies are focusing on one moment of the life of the knowledge resources: capture - transformation - representation - dissemination.

In particular, this work highlights an important need to support the makers in their content capture step. It also appears that some of these tools offer to automate some of the cumbersome steps of resource creation, such as the transfer of content, image processing or resources representation. Finally, we found that tools found in the literature are lacking interoperability, and should provide opportunities for different kinds of representations of the resources and enable makers to appropriate their resources for any use.

From this chapter, we derive several research directions that are explored in the rest of this thesis, focusing on content capture which is central to every type of resources.

The aim of Chapter 4 will be to better understand the aspects of content capture in fabrication workshops, identifying the different dimensions. These dimensions are used to go further with the analysis of tools to support knowledge resource creation, focusing on capture aspects.

Chapter 5 goes deeper into the important aspects of capturing, in particular on the practices of makers according to their objectives and their practice, and will explore some aspects of automation during content capture.

Finally, Chapter 6 discusses how the automation of certain aspects of knowledge resource creation can be considered and desired in the context of fabrication workshops.

Content Capturing for Knowledge Resources in Fabrication Workshops

4.

The previous chapter focused on the objectives of knowledge resources where my co-authors and I identified many challenges for which the content capture step is central. While we have briefly described the reasons why capture is so challenging, we have only scratched the surface of the topic of content capture by identifying its difficulties in broad terms. This chapter now considers capturing as an activity taking place in and constraint by a given space. Content capture is considered as recording any aspect related to a fabrication project, such as pictures, videos, audio, a 3D object definition, or fabrication machine parameters that aims for the creation of knowledge. First, I will identify the different dimensions of content capture in fabrication workshops. For that, I present a framework that my co-authors and I published in [108]: Rigaud et al. (2022), ‘Exploring Capturing Approaches in Shared Fabrication Workshops’. This framework is structured around a set of questions known as the *5W1H* (*why, what, when, where, who, and how*). For each of these questions, we analyse past work to identify a set of properties with which we describe content capture in fabrication workshops. Then, I reuse the selection of tools presented in Chapter 3, to show how this framework allows to describe and compare capturing capabilities of both existing and new research.

4.1 Framework: Content Capturing for Knowledge Resources in Fabrication Workshops	66
4.2 How to Use This Framework	77
4.3 Discussion	83
4.4 Conclusion	86

4.1. Framework: Content Capturing for Knowledge Resources in Fabrication Workshops

Content capture can be deconstructed along several dimensions. First of all, Chapter 3 (section 3.2) established that capturing content from fabrication activities serves several objectives (*Why*) linked to the creation of knowledge resources, and makes it possible to include different modalities of knowledge (*What*) (picture, sound, video, ...). subsection 3.3.2 highlighted that different strategies exist to support the capture of this content (*How*). Moreover, Chapter 2, subsection 2.2.1 presented the way in which the fabrication activities are distributed in several places of the workshops (*Where*), and take place at different times (*When*). Finally, Chapter 3 suggested how the automation of some steps of the resource creation could be a way to facilitate the work of makers, and that some aspects of the resource creation could thus be managed either by the maker or by the system (*Who*). Using these *5W1H*

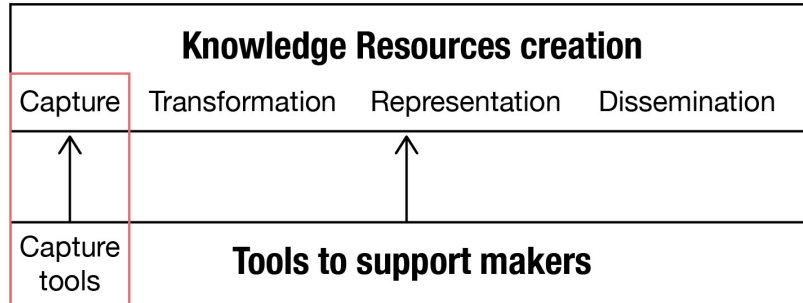

Figure 4.1.: This figure shows how this chapter and the resulting framework integrate with the previous one, focused on knowledge resource creation

questions, we now focus on content capture in the fabrication workshop as shown Figure 4.1 and provide a framework dedicated to capture. This framework complements the analysis of the previous chapter as it emphasises the capture stage on the one hand, and on the other hand it integrates capture objectives going beyond the creation of knowledge resources.

In the following sections, underlined words are used to refer to the sub-dimensions of our framework.

CONTENT CAPTURE		KNOWLEDGE RESOURCE	
Objectives	Examples	Objectives	
Community	<i>Machine presets</i>	Reuse one's work	Represent a fabrication project
Individual	<i>Picture or video as a story on social networks</i>	Communicate	
	<i>Reflection-In-Action Feedback on task</i>	Support reflection	
Organisational	<i>Meta-information</i>		

Figure 4.2.: This figure shows how objectives for knowledge resources articulate between the moment of the capture and the moment of the represented resources.

4.1.1. Why to capture?

The why dimension of this framework describes the objectives of capture related to fabrication projects. Content capture is the starting point for the creation of knowledge resources. Thus, content capture allows the pursuit of the objectives identified in the previous chapter, once transformed and represented. However, the previous chapter looked at higher level objectives and challenges, whereas in this chapter these objectives are considered at a closer level for more immediate goals.

At the stage of content capture, these objectives can be classified differently and refined. We describe these objectives in terms of three levels: community level, individual level and organisational level. Figure 4.2 shows how these objectives are articulated according to the state of knowledge resource creation: capture vs transformed knowledge resources as described in Chapter 3. This figure shows, for each line: on the left the objectives and corresponding examples for the content capture, on the right the corresponding objectives of the knowledge resources as presented in the previous chapter.

At the community level, a common objective is to allow the creation of resources that can be *reused by others* (subsection 3.2.2). As explained in section 3.2, the resources can enable to teach by sharing both explicit and tacit knowledge, so that others can learn by replicating, remixing, or extending previous projects [94, 112]. At the stage of the capture, this objective can be pursued by providing simpler content to

Stages of resource creation (Chapter 3)
We identified 3 stages of knowledge resource creation: capture, transformation, dissemination

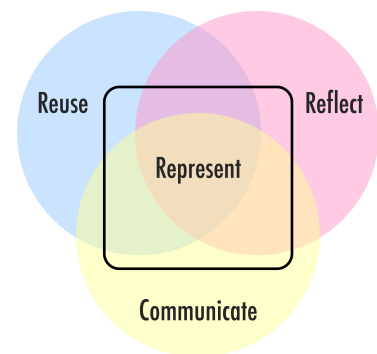

Figure 4.3.: We identified 1+3 objectives for knowledge resource creation in Chapter 3. **Represent** a fabrication project, transversal to all resources, **Reuse** one's work, **Support reflection** and **Communicate**.

others. As an example, makers can save machine presets after performing successful tests on a given material so others can reuse it. Figure 4.4 shows how one can save power, speed and frequency parameters inside the software controlling a laser cutting machine for cutting or engraving.

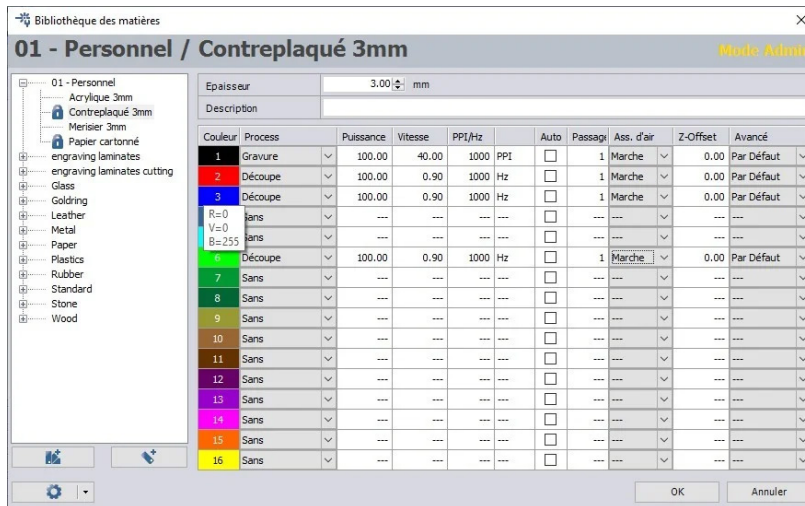

Figure 4.4.: Some applications to control CNC machines allow users to save presets - this figure shows the interface of a library of presets for a laser cutting machine

At the individual level, the previous chapter reported that content capture can be used to generate resources for the maker to *communicate* (subsection 3.2.4) and *support their reflection* (subsection 3.2.3). First, the objective *Communicate* (subsection 3.2.4) described how knowledge resource creation allows to build an identity through demonstrating skills, inspiring others and communicating ideas [77, 91, 101, 110]. At the stage of the capture, communicating can be done also with simple content such as pictures of work in progress published on social networks. At the age of platforms such as *Instagram*, *TikTok*, *Twitter* etc., popular mobile applications allow the content just captured to be shared with a community in real time, as illustrated with Figure 4.5.

Second, the objective “*Support reflection*” (subsection 3.2.3) described how knowledge resources can be a tool to track the progress of the makers. *Supporting reflection* can take another form at the fabrication activity and capture stage. Indeed, Schon [113] propose to nuance two types of reflections: Reflection—*ON*—action and Reflection—*IN*—action. As seen before, the resources can enable makers to reflect on their process [103], (*ON*—action [54, 113]) as they depict a broad view on the trajectories taken throughout the project. At the scale of an activity, capturing content for the creation

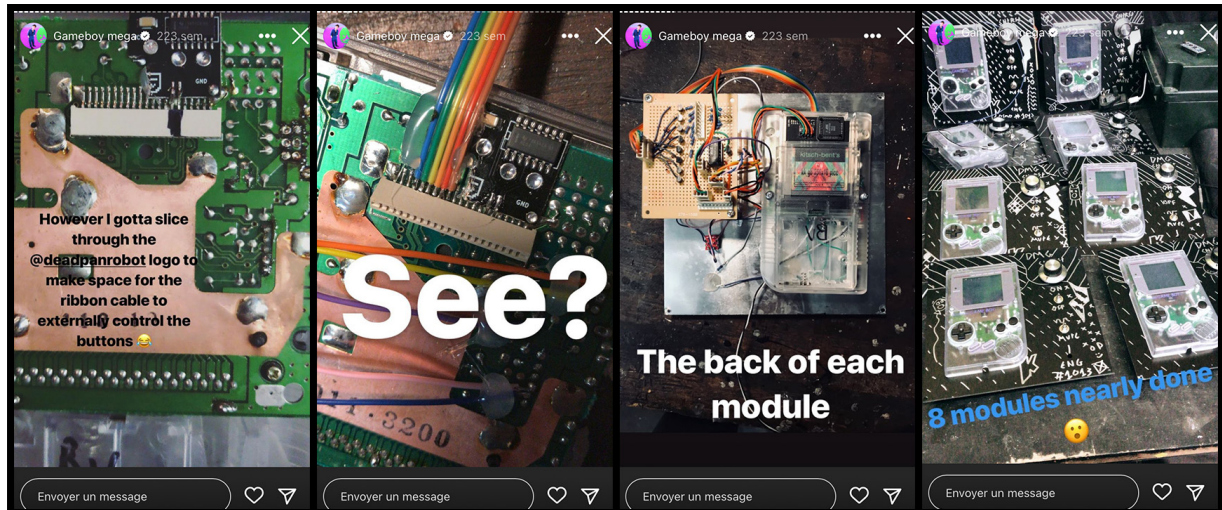

Figure 4.5.: Instagram stories showing real time work in progress published by @lookmumnocomputer

of resources enables Reflection—*IN*—action: Capturing is a way to engage with the design process [13] as making intentional traces during an activity gives the opportunity to step back and to engage with the materials and tools, to have a different point of view of the activity while doing it and thus Reflecting—*IN*—action [54, 113]. In addition, a special case and motivation for capturing activities is to provide feedback during a fabrication activity, generally to guide makers in achieving their goals, for example, to dynamically communicate process information such as task progress and safety warnings [74], the maker’s level of mastery of a tool [53], or to suggest an improved technique for the current task [22].

Finally, capturing content is also useful at the organisational level to extract *meta* knowledge resources and support the management of fabrication workshops [87, 92]. For example, systems can collect information about ongoing projects or provide overviews of the fabrication workshop activities and machine usage for decision support and space planning [53, 92].

While capturing content is beneficial at different levels (*why*), it is exposed to different barriers (*why not*). Chapter 3 identified the different challenges that makers face when creating knowledge resources, and we saw that many of the challenges occur at the content capture stage, during the fabrication activity. When makers work in the workshop, they generally devote most of their attention to the task at hand. The cap-

ture requires them to shift their attention from fabrication to capture, a costly process that often leads to forgetting to document. Both the fabrication and capture tasks also require physical manipulation on the part of the makers, especially with the hands. Capturing content and performing the fabrication activity are two conflicting tasks, both cognitively and physically. These barriers lead to not only fewer resources, but also resources which are incomplete or less rich than what makers wish for and thus are often not Reused [138, 144] and do not enable to Support Reflection—*IN*—Action.

4.1.2. What to capture?

Fabrication workshops host a wide range of activities from 3D printing over textile knitting, wood working to micro-controller programming (Chapter 2). This variety of activities may require makers to capture different types of content when working in the fabrication workshop. This dimension of the framework therefore describes the *modality* of knowledge that can be captured.

Visual content, pictures and videos are popular content types and, when enriched with text, build the basis of many knowledge resources [77, 132]. Indeed, pictures and videos can often efficiently communicate an idea, illustrate the steps required to create an artefact or demonstrate how an artefact can be used. However, pictures and videos are used differently. Videos are often considered more suited to capture processes [25], for instance, when communicating the gradual progression of a movement, which is complex to accurately recompose from static pictures. They are also more engaging [77] when the objective is to *communicate*. While this may reflect habits and opinions in the context of fabrication workshops, past work has shown that for some learning tasks, static pictures combined with text are more appropriate than videos [62], and that static diagrams can effectively communicate assembly instructions [2].

In addition to visual content, other formats may be relevant as well, such as audio [91], annotations [24, 26] or design files [132]. Indeed, as described in subsection 3.2.2, to *reuse one's work*, annotations explaining the *procedure* or information

Fabrication knowledge (subsection 2.3.1)

According to the grid of Jong and Ferguson-Hessler [69], modality of knowledge is described as the form in which this knowledge is represented, which can be a text, a picture, a video, a diagram, etc.

specifying *contextual knowledge* are crucial for a better understanding, and design files are a key to enable someone else to reproduce a project [144].

Going beyond these universal *modalities* of knowledge, other types of contents can be captured from fabrication activities, in particular contextual information on the activity. These information can be the identification of the user [75], the name of a project, the processes and methods involved, the used machines (e.g., 3D printer), tools (e.g., screw driver), components, materials and the type of source files. Captured content can also be more abstract such as location or timestamp [104], identifiers from RFID cards [20], or tags located on physical objects [41, 123], information about the environment such as the current state and location of a tool [64, 74, 114], or even serial outputs from a micro-controller [75].

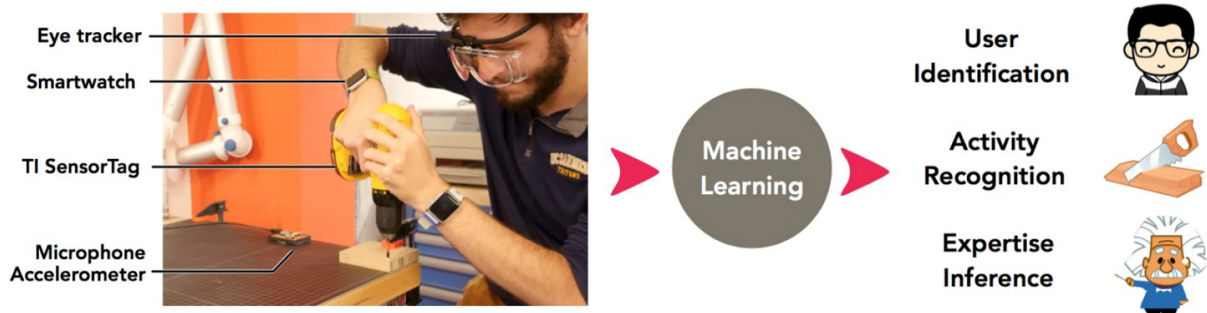

Figure 4.6.: Gong et al. propose to equip makers and the workshop with various sensors aimed to gather different kind of data to compute contextual knowledge about the fabrication activity.

Combined together, these information can better represent the context of the activity going on. As an example, Gong et al. [53] (Figure 4.6) proposes to collect different types of data: visual flow, audio, motion, temperature, humidity, luminosity and biometric sensors. They study the contribution of each of these data from different machine learning models, to allow the identification of the user, the recognition of the activity in progress as well as the level of expertise of the user. As a way to structure these contextual information, Troxler and Zijp [134] introduced the concept of FabML, a specification format based on XML to capture and exchange fabrication activities. FabML aims to provide a structured language to capture an activity together with relevant contextual information.

Situated knowledge (subsection 2.3.1)

Contextual information can convey “Situated knowledge”, which allows information to be interpreted in one way or another. In the case of fabrication, context is particularly important because the stages of a project usually consist of a variety of activities.

4.1.3. How to capture?

The *How* dimension describes the technologies and properties that can be used to capture content. Different types of devices can be used such as physiological sensors, Inertial Measurement Units which are also commonly used in augmented reality to capture the manipulations of a user [29]. The sensors can also allow the scanning of RFID chips [20] or tags [41]. For the creation of knowledge resources how-

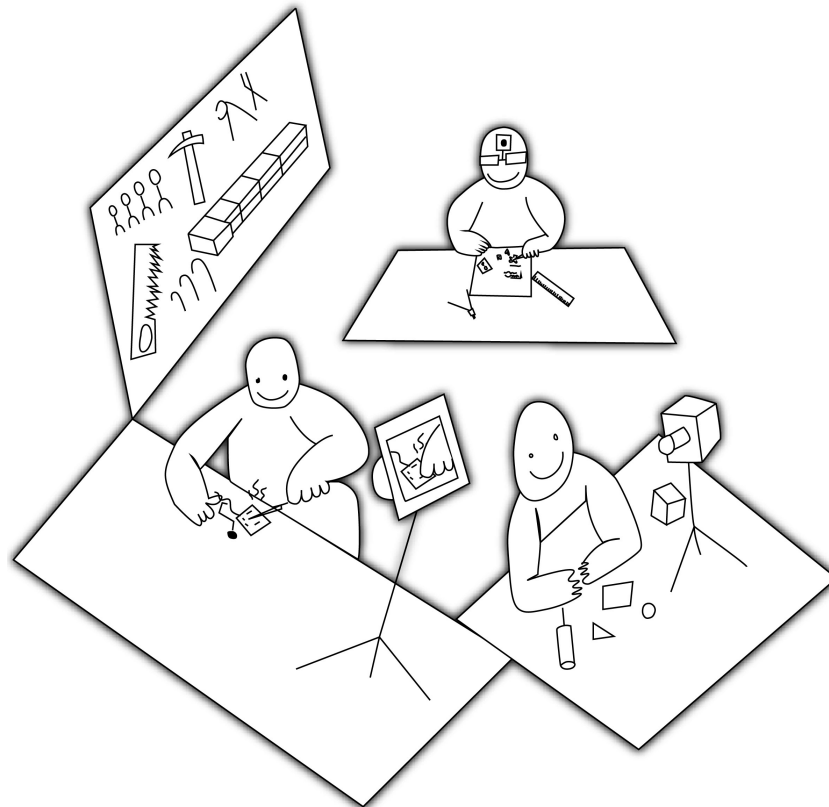

Figure 4.7.: Workshops can be equipped with community hardware devices to support makers during the capture of their activities

ever, the most prolific technologies are vision-based sensors. Visual content is an integral part of knowledge resources and visual sensors are present in most of the tools used by makers for resource creation. Some workshops provide makers with devices to support knowledge resource creation. Nevertheless, most of the makers are equipped and use their personal devices to capture visual content. Thus, we distinguish here between personal devices and community devices.

Capturing visual activity traces is often done using personal

devices like smartphones and tablets. They provide a quick and effective way to produce high quality pictures, and makers already bring them along into the workshop [25, 72]. Youths are especially comfortable using them to capture and share on platforms such as *YouTube* or *Instagram* [83, 101]. Because these devices have several sensors readily available, they can also be used to capture additional content, such as audio for orally annotating a video simply by speaking when the camera is recording [91]. However, makers' personal devices also have important limitations. First, used on their own, they generally constrain hands-free manipulation [26] and thus limit a maker's ability to work and record at the same time. Thus, as detailed by Keune et al. [72], most smartphones require mounting devices which can be costly to set up and suffer from inconveniences such as the screen going to sleep or conversely the device running out of battery. More importantly though, due to the fact that they are ubiquitous multi purpose devices, their sheer presence is unlikely to serve as an effective reminder, makers are likely to forget about their presence, and consequently forget to capture their work [72].

Chapter 3 section 3.3 reported that some fabrication workshops provide makers with community devices to capture content, often in the form of dedicated stations specifically for capturing picture and video. They typically include one or multiple cameras pointing towards an area reserved for capturing artefacts during a project, some form of lighting system to ensure good visibility, and in some cases additional mechanisms to facilitate the annotation of a project.

Different types of these stations were introduced in subsection 3.3.1 such as *Dodoc* [55], which features different modules including a lamp and a fixed camera pointing down at a documentation area to record video, still pictures, or build animations; *Protobooth* [11, 40] which captures different point of views of a prototype with several fixed webcams pointing toward a platform; *Fabnavi* [140], a camera/projector assembly mounted on top of a table; and *Spin*, a camera combined with a turntable to generate animated GIFs of a 360° overview of a fabricated object [136]. These stations can also be made of DIY mounted toolkits to hold a smartphone or tablet and enhance the salience of the capture device [72]. While such stations are promising in many aspects, they do

Categories of tools (section 3.3)

We introduced 3 categories of tools to support makers in the creation of knowledge resources: software tools, fixed hardware tools and mobile hardware tools.

not provide mobility and thus constrain to work where the station is installed or to interrupt one's work and transport artefacts over to the station.

Lastly, special devices can capture and transform other kinds of data into video streams such as depth information (e.g., from a Microsoft Kinect) as done in Duplotrack [60] for recognising assembly tasks, optical tracking streams such as in AuthAR [146], or temperature fields through infrared cameras in the case of blacksmith crafts [7].

4.1.4. When to capture?

Capturing content can happen at different moments in a fabrication workshop. When the objective is on showcasing a final product to *communicate*, capturing happens after an activity [136, 138], to show the final outcome of a project. Capturing the content at the end of the activity is the least likely time for difficulties, since the makers are not busy with other things, and the feeling of satisfaction with the finished work may encourage documenting.

Capturing content during an activity has several advantages: it allows makers to keep track of *reflections* and decisions they made at the time of the activity [32, 135]. This is also the time when Reflection—*IN*—Action [54] can take place. Capturing during the activity is also important not to forget important information that others could *reuse*. Yet as described in subsection 3.2.1, capturing while focusing on a primary task is a main challenge. It imposes a break of flow as it requires to switch from a primary to a secondary task, which adds time and, most importantly, needs to be remembered. It is common to postpone or simply forget to capture the process and only capture the result [138, 151]. As a consequence, important (mis)steps [138] go missing and only the successful ones are captured [67, 84, 91, 135]. The result is that many knowledge resources are not adapted or reused [138, 144].

Finally, some types of content, such as sketches, drawings and CAD files, are created before they can be fabricated and can be captured for their later use in a tutorial or documentation [41, 70, 144].

4.1.5. Where to capture?

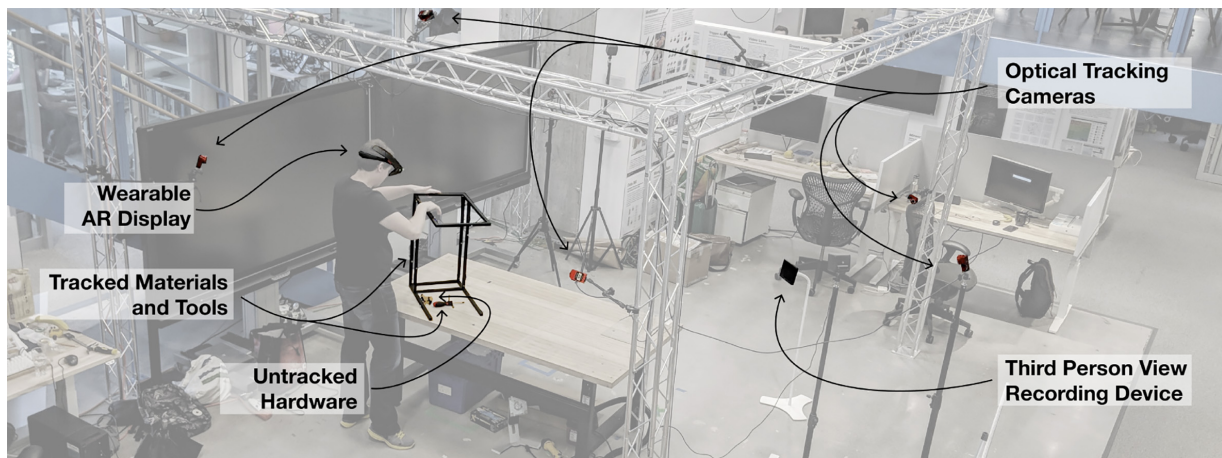

Figure 4.8.: Whitlock et al. [146] introduced AuthAR, a tool based on multiple sensors located in different places of the environment, on the user and on tools.

Subsection 2.2.1 explained that fabrication workshops are often laid out so that different types of activities happen in different areas [8]. Thus, makers need to move between areas, such as from a workbench where they are sketching and performing 3D modelling to a machine area where the 3D printer is located. Inspired by Gong et al. [53], we identified three types of placements for capture tools.

First, cameras or sensors can be attached in the environment, in a fixed fashion, e.g., mounted to a wall, or in a mobile fashion, e.g., on a tripod [26, 140]. *Fixed cameras*, such as downward-oriented cameras attached to the ceiling or on an auto-pole can provide an especially appropriate view for areas dedicated to specific activities [72] or in the case of documentation stations such as DoDoc [55]. Although fixed cameras provide a stable video result [140], they may not be appropriate for all activities, for instance, makers might want to capture a video of their artefacts at different locations (e.g., in front of a green screen or in a quiet place), where no cameras are installed. Relying only on fixed cameras would require a very high number of installed cameras, especially for large spaces. *Mobile cameras* offer more flexibility as they can be moved around in the space. Nonetheless, they also have drawbacks as their use increases the risk of occlusion by a person or an object, especially when using a tripod [26]. Additionally, tripods require extra manipulations, are obtrusive, and can hinder the mobility of people in a workshop.

Layouts of the workshops (subsection 2.2.1)

Using a case study of several workshops, Annett et al. [8] showed that most of these places are open spaces with a series of areas dedicated to certain activities, including a computer design area, a woodworking area, an electronics area and so on.

Second, cameras or sensors can move with a person, for instance, by holding a smartphone, recording sensor data from a smartwatch [3, 53], or wearing a GoPro¹ on one's head. Head-mounted cameras enable hands-free interaction and provide a first-person perspective as illustrated with ShowHow [25] in Chapter 3, which can improve performance on assembly [76] and learning [83]. However, footage from first-person cameras often lacks stability in comparison with cameras in the environment [26], which tend to provide higher quality videos.

1: <https://gopro.com/>

Finally, sensors and cameras can be attached to a machine such as a 3D printer, a laser cutter or a drill bench, capturing when and how specific machines are used [53]. Such fixed installation can have the advantage of optimising the viewpoint for good visibility.

4.1.6. Who captures?

In the context of this framework, *who* refers to who initiates and controls content capture and related properties. In most cases, makers manually capture content by positioning and orienting a camera, adjusting its focus (even if this one is often automatic) and triggering (start/stop) the recording. They also often manually manage content, for example, by uploading it to a shared repository [121]. Manual control requires immediate *feedback* of what is being captured to check whether the objects of interest are in the field of view of the camera and whether the camera focus is correct [26]. Makers receive this feedback by annexing screens such as smartphones [91], by using dedicated screens [55] or by using augmented reality through video-projection [140] or wearable devices like Google Glass [26]. However, manually setting these parameters can be difficult when working, especially when the cameras are not directly accessible [26].

Automated capture has the potential to reduce cognitive and physical demands on makers, to let them focus on fabrication (their primary task) [26] and to free their hands to manipulate objects [72]. However, only few prototypes rely on this approach. For instance, Spin [136] automatises the orientation of a camera by the means of a turntable to create animations

of a 360° view of an object. Protoboost [75] creates 3D representations of an object via photogrammetry. However, we are not aware of approaches that, in the context of fabrication activities, automatically orient a camera to keep a moving tool or person in focus as was done, for example, in the context of recording moving presenters [148]. Some systems store automatically the content in a centralised place, following a specific organisation to make the retrieval easier. Centralised repositories can then automatically create links between records (e.g., tool usage or interactions), data-entries or projects [118]. For instance, Erichsen et al. [40] proposed a system that automatically captures timestamp meta-data associated with a project, enabling the visualisation of the different prototypes' iterations. Some argue that automated capture needs to be approached carefully though. For example, Keune et al. [72] raise two concerns: First, the process of taking a picture or recording some part of a process is the fruit of a reflection that is important, especially in a learning context, and should be made consciously; secondly, automated capture is likely to lead to a longer curation process due to a larger amount of captured content to review. Chapter 3 highlighted that automated techniques to create knowledge resources have also been explored to facilitate the work of the maker during the steps after the capture of content. Such explorations include automated image processing and documentation authoring [91] or automated video-tutorials based on the activity or movements recognition [3, 22].

4.2. How to Use This Framework

Table 4.1 provides an overview of the 5W1H dimensions (column 1), properties within (column 2), and how different systems compare to each other (remaining columns). System designers can consider *systematically* each dimension and the associated properties, to **describe** and analyse a capturing system they implement, **compare** it to existing systems, and, most interestingly, to identify gaps and **generate** systems with novel capabilities.

To illustrate how to use this framework, we propose to proceed with an exercise similar to the previous chapter but this

	Generic smartphone Dodoc Fabnavi Spin ShowHow Document While Doing Protoboosth	[55]	[140]	[136]	[26]	[91]	[11, 40, 75]	
Why	Community benefits	■		■	■	■	■	
	Individual benefits	■	■		■	■	■	
	Organisational benefits						■	
What	Pictures	■	■	■		■	■	
	Timelapses	(■)	■	■	■			
	Videos	■	■			■		
	Sound annotations	(■)	■			■	■	
	Text annotations				■	■	■	
	<i>Contextual meta-data:</i>							
	Project ID			■			■	■
	Tools/machine Location	(■)						
How	<i>Kinds of systems:</i>							
	Community device		■	■	■	■		■
	Personal device	■				■	■	
	<i>Properties:</i>							
	Mobile	■				■	■	
Multiple								
Hand free		■	■	■	■		■	
When	Before							
	During	■	■	■		■	■	
	After	■	■		■	■	■	
Where	Environment		■	■	■	■	■	
	User	■				■	■	
	Machine/Tool							
Who	<i>Automated properties:</i>							
	orientation				■			■
	position							
	contextual meta-data							■
content management		■	■	■	■	■	■	

Table 4.1.: Comparison of different vision-based capture tools using the framework from section 4.1. For comparison we also include how the use of a generic smartphone compares with more specialised systems. Brackets indicate that a property depends on the concrete device choice or implementation (only applies to generic smartphones).

time, focusing on capture aspects: In section 3.3, we had selected 8 tools to support makers in the creation of knowledge resources, 6 of them allowing to capture content. This selection of tools is revisited to demonstrate how our framework can be used to describe and compare different approaches to enable the capture of visual content. Figure 4.11 recalls the tools introduced in section 3.3 and illustrate some of their properties according to our framework.

4.2.1. Describing capture tools

First, the framework allows to describe the tools according to the 6 dimensions. We illustrate this using two examples: Dodoc [55] and Proto booth [11, 40, 75] (Figure 4.9).

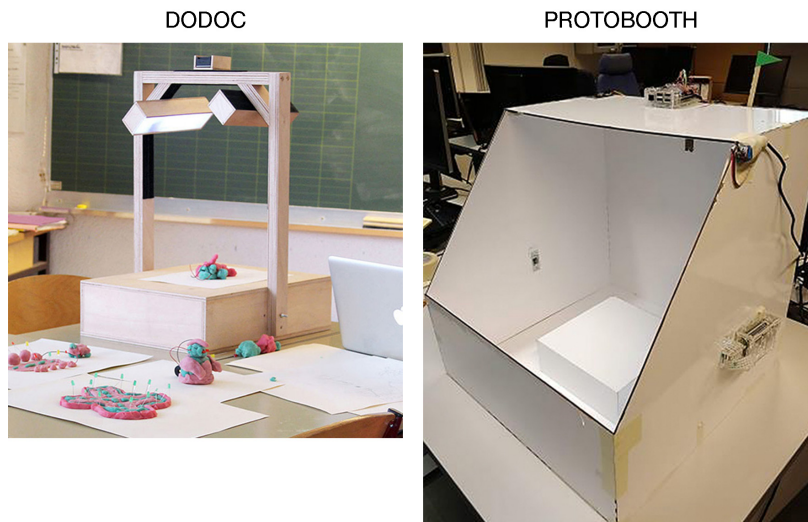

Figure 4.9.: Dodoc and Proto booth are two documentation stations installed in fabrication workshops to gather visual content about fabrication activities.

Chapter 3 presented DoDoc's main goal which is to support reflection (*Why*: individual benefits). It captures pictures, video, and sound annotations, and because of its fixed property (*How*: not mobile), can capture timelapses² (*What*: pictures, videos and sound) The station is shared among users and can be used hands-free (*How*: hands-free community device). It can be used both during and after fabrication activities (*When*: during and after), however, since it is located at a fixed place (*Where*: environment), makers may need to interrupt their activities to capture content *during* an activity. Finally, makers need to position and orient the camera manually, but Dodoc manages content automatically (*Who*: user - for manual orientation and position, but *Who*: system - for content management).

An other example to describe with the framework is Proto booth. As described in Chapter 3, Proto booth allows to create knowledge resources in the form of a web page allowing to reproduce the project (*Why*: community), to support the reflection of the makers and to interact with a community through comments (*why*: individual). However, in a version of the tool presented by Erichsen et al. [40], the authors also show how the captured metadata can be used to generate

2: Timelapses are animations of a sequence of pictures taken from the same view angle during a certain period of time and showing the accelerated evolution of a scene.

visualisations from the projects designed in the fabrication workshop (*Why*: organisational). Figure 4.10 shows a visualisation of the different uploads of the projects in the workshop divided according to the hours of the day and the days of the week. This allows to have a view of the overall activity of the workshop according to days and time slots, as well as to follow the activity of a given project.

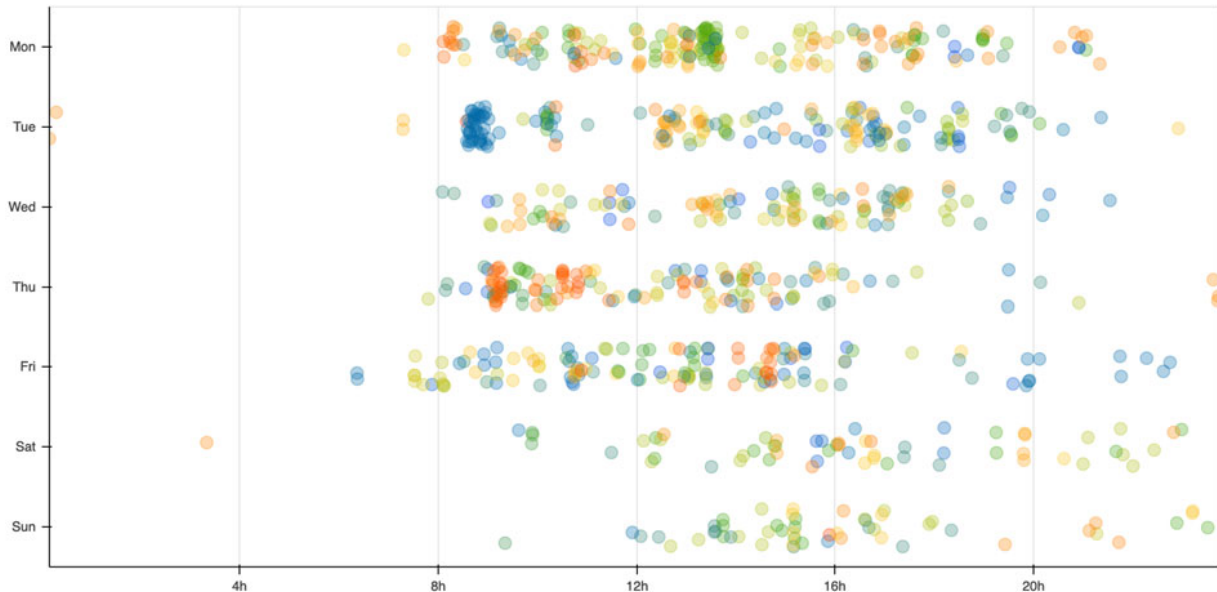

Figure 4.10.: Protobooth uploads by time of day (horizontal axis), sorted by weekday (vertical axis), with colours indicating different projects.

Protobooth captures pictures, RFID linked to projects and timestamps (*What*: pictures, Contextual meta-data: project ID, timestamp) It is designed as a fixed station placed in the space (*Where*: environment), shared between users, and allows to manipulate the objects during the capture (*How*: community device, hand free). However, it does not really allow to capture during the fabrication activity but rather at the end of a design stage (*When*: after). Finally, in a version of the tool presented by Kohtala et al. [75], the station is equipped with an automated turntable, allowing to capture 360-degrees views. It thus has different properties managed by the system (*Who*: system) orientation of the view, capture of contextual meta-data, and management of the content, as the content is automatically uploaded on the editing platform.

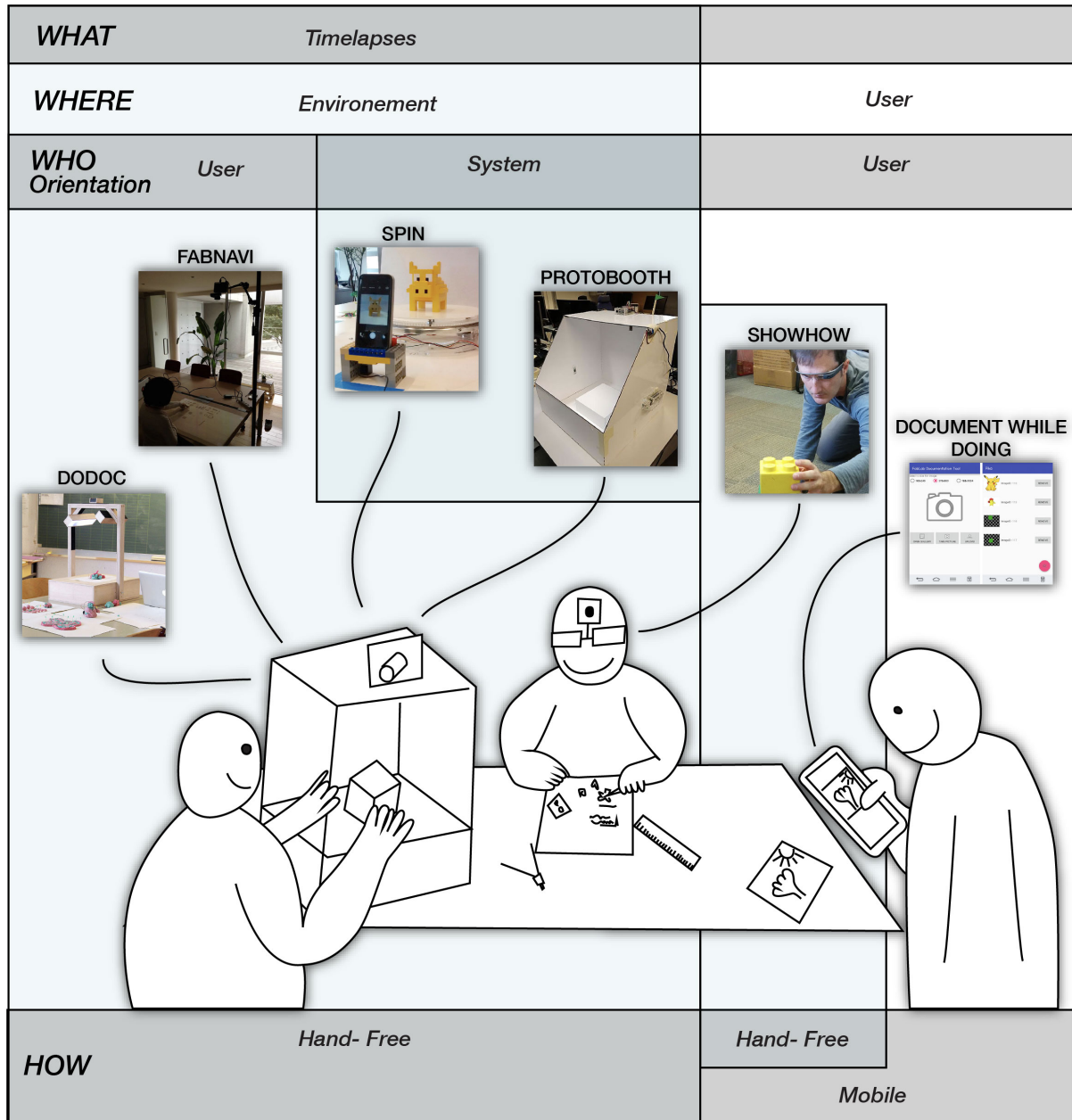

Figure 4.11.: Figure illustrating 6 systems for capturing visual content. We distinguish systems according to some properties of the dimensions of the framework

4.2.2. Comparing capture tools

Dodoc and Protobooth can also be compared to each other and other systems using this framework: Table 4.1 illustrates this for generic smartphones and a selection of five other systems which together provide an overview of the breadth of different capturing approaches. It is worthy of note that the comparative power of the framework lies in that it lets designers compare dimensions which were not necessarily

explicitly addressed in the articles describing each individual system.

For example, concerning the *What* dimension, we gave the example of Protobooth whose simple collection of data of project identifiers and time of uploading allows benefits at the organizational level (*Why*: organisational benefits). Fabnavi [140] and Document-While-Doing [91], collect the project IDs, and it seems likely that the other systems presented here collect these two pieces of information: the time of upload and the project or user ID. It should therefore be quite easy to provide organisational benefits to these other tools as well.

Systems can also be compared along several dimensions: For example, the dimension *What* to capture is strongly related to the dimension *How* to capture: Timelapse capture (*What*: timelapses) is made possible by tools based on the concept of fixed stations (*How*: not mobile): Dodoc [55] Fabnavi [140], and Spin [136], which make it possible to capture homogeneous views. Protobooth, which is also a fixed station, could allow this. It is also interesting to compare the tools according to the mobility they allow to the user: (*How*: mobile). Considering the mobility and the point of attachment of the capture tool (*Where*), it stands out that the systems allowing mobility (generic smartphone, Showhow [25], DwD [91]) are carried by the user (*Where*: user), and that of these mobile systems, only Showhow proposes to attach the capture tool on the user's head, thus freeing his hands for the manipulations during the activity (*How*: hand-free). Other tools that allow hand-free manipulations are fixed stations, but compromise mobility (*How*: mobile).

Finally, the tools can be compared along the *Who* captures dimension, which shows that Spin and Protobooth stand out from the others by offering to automate the orientation of the capture point of view. As discussed before, Protobooth also collects contextual meta-data automatically and uses it for organisational benefits, which is not the case for the others. Interestingly, all the systems allow for automated transfer of content to a management system, unlike the case of the generic smartphone, which involves the user transferring the content on their own.

4.2.3. Conclusion

This section demonstrated how our framework can be used as an instrument to describe and compare different tools for capturing visual content in fabrication workshops (descriptive and comparative power). The next section is a discussion on how this framework can also shed light on some under-explored dimensions (generative power). This generative power lies in that the framework elicits which dimensions and properties are currently under-explored, which future work may find valuable to facilitate the communication of new contributions. Of course, the framework does not include all potential future properties and classes within each of the 5W1H dimensions, but it can easily be extended as needed to demonstrate the novelty of some future contribution.

4.3. Discussion

After demonstrating how this framework can be used as a instrument to describe and compare different visual capture tools, we discuss the generative power of our framework, then we highlight two key opportunities for design that show divergences and alignments between making practices and capture tools.

4.3.1. Generative power

First, the **Why** dimension shows that while *community* and *individual* benefits are commonly used to motivate the capture of content in fabrication workshops, *organisational* benefits such as providing an overview of the fabrication workshop activities [92] also serve organisational purposes but are less often considered. However, the example of Protoboost illustrated that the capture of rather basic *contextual information* such as Project ID and timestamp can already provide benefits for the workshops' organisation and similar tools could benefit from this advantage as well. This is related to the **What** dimension, in which we find that despite the wide range of devices, the capture of visual content such as *pictures* and *videos* is most prevalent, alongside *text* and *sound* annotations

even though capturing information about the context appears to be relevant. Regarding the **How** dimension, many tools from literature are *community devices*, which may be due to the observation that makers tend to forget more easily to capture when using their *personal devices* [72]. Many of these *community devices* provide *hands-free* operations, which is not surprising given that this is one of the essential barriers to content capture (as discussed in Chapter 3 section 3.2). With regard to **Where** capturing takes place, we observe that most tools opt for a placement somewhere within the *environment* as stations.

Worn capture devices have not been studied much and could be explored further as they provide opportunity for *hands-free* operations as well as for *mobility*. A direct placement of the capture tool on machines or tools remains to be explored as well.

Concerning **When** capturing takes place, many systems aim to increase support *during* the activity, since leaving it for *after* the activity risks leaving out potential mistakes, which could be valuable to include for future makers learning about this activity [138]. It also makes it impossible to get internal shots for things that are closed at the end, and generally puts the emphasis on the final result and not the process.

Lastly, regarding **Who** controls capturing, we find that *community devices* have the advantage of enabling an automated transfer of the content captured with the tool, to a repository or editing interface. Despite this important aspect, most approaches are primarily manual, with previous work providing little guidance on what degree of automation may be considered desirable by makers and the level of agreement on that question.

From these observations and the one made in the previous chapters, we highlight two design opportunities which are promising to explore: Supporting Diverse and Distributed Activities, and Exploring Automated versus User Control

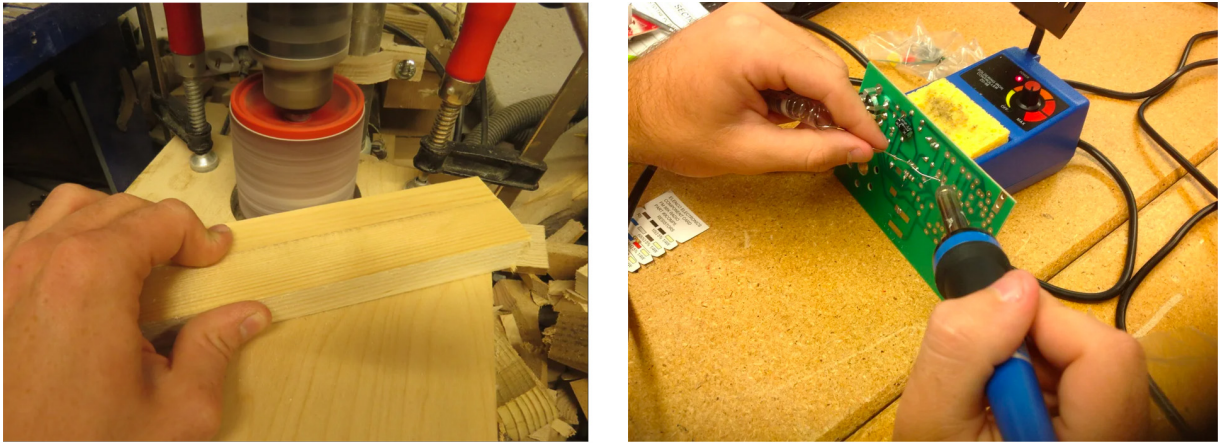

Figure 4.12.: Pictures taken from steps of tutorials found on Instructables.

On the left, the picture shows a maker sanding a board (Source: Instructables “Drum Sanding Table for the Drill Press” www.instructables.com/Drum-Sanding-Table-for-the-Drill-Press/)

On the right, the picture shows a maker soldering a component on a circuit board (Source: Instructables “Soldering” www.instructables.com/Soldering-3/)

4.3.2. Opportunity for design: Supporting Diverse and Distributed Activities

There seems to be a paradox on the “How” dimension. On one side, we observe that a large number of systems are dedicated to very specific activities, often restricted to a limited area, such as a workbench, or to small objects and prototypes. They are generally composed of a single camera installed at a specific location, such as Dodoc [55] or Fabnavi [140] that are built as stations to capture the different steps of an assembly task by taking pictures from the top of a workbench. However, Chapter 2 subsection 2.2.1 reported that fabrication workshop involves *diverse activities* happening at different locations and machines *distributed* throughout a workshop [8]. For example, makers may need different point of views depending on the activities [26]: as shown Figure 4.12, a maker performing small electronics manipulations might not need the same point of view than a maker sewing or sanding a board. If the capture device is attached in a fixed fashion in the environment, as it is the case with documentation stations, all the activities may not benefit from the tool.

Some prior work proposed to make use of existing mobile devices [26, 91] which are more appropriate for distributed activities, but these still rely on a *single* camera. This implies that makers need to move their device between the differ-

ent areas in which they work and adjust its positioning and other parameters based on the specific needs of the different activities they carry out. As an example, a maker doing a woodworking project might want to film a step in which they are sanding an object, and then create a “before/after” timelapse of the sanding and painting steps. It would be cumbersome for them to use their smartphone to film the process of sanding and painting, and to keep a tripod in place to take homogeneous views for the timelapse.

4.3.3. Opportunity for design: Exploring Automated versus User Control

On the “*Who*” dimension, we believe that there are missed opportunities. We observe that most approaches rely on *manual* controls (one exception is camera focus which is generally controlled automatically). Although manually controlling capture properties can help makers build expertise and reflect in and on action, the main activity of making is cognitively and physically demanding and requires, among other things, creative work, vigilance, and coordination with others. Therefore, *automating* at least some of the parameters listed under *Who* in Table 4.1 seems promising to let makers focus more on their main activity. This has not been studied much in the context of fabrication workshops, and it remains unclear which feature(s) should be automated and when. We argue that the *Who* dimension deserves more research to explore how makers could benefit from mixed-initiative approaches [6], *i.e.*, combine the advantages of both manual and automatic control.

4.4. Conclusion

Chapter 3 identified several challenges to the creation of knowledge resources. Chapter 3 concluded that many challenges for knowledge resource creation already occur at the capturing stage. Therefore, this chapter explored content capture in fabrication workshops in more depth, in order to better understand its different dimensions. For this purpose, we carried out a literature review which resulted in a framework

based on the principle of the 5W1H questions. We decompose content capture according to 6 dimensions, which can allow a more analytical study of this task. This highlights that content capture can go beyond visual content capture and benefit makers and fabrication workshops for other purposes than knowledge resource creation, for example by providing opportunities for feedback on tasks in real time, or overviews of the workshop activities. This also shows that the content capture task, already identified as difficult in Chapter 3, is in fact difficult for several reasons and levers can therefore be activated in several of the dimensions. As such, the framework can be used to describe and compare existing capture tools, for example to observe which of these levers they adopt, or not. To illustrate this, we reanalysed 6 systems from Chapter 3, but this time focusing on their capture properties. These systems were described and compared together and with the use of a generic smartphone. After discussing the generative power of the framework we highlighted two main opportunity for the design of visual content capture tools:

- ▶ Supporting Diverse and Distributed Activities
- ▶ Exploring Automated versus User Control

I will explore these two design opportunities in the next chapter.

Exploring Visual Capturing Approaches

5.

The previous chapter analysed aspects of content capture that need to be explored in more depth. In particular, we highlighted the need to explore how capture tools can support a diversity of spatially distributed activities, and to explore the automation of certain properties of these capture tools.

Thus, in this chapter, we break down these two research directions into three dimensions: multiplicity (number of capturing devices), variety (property homogeneity between capturing devices), and degrees of automation of the properties of these capture devices.

We first develop a design concept, termed Capush, composed of *multiple* camera-based units, *varying* according to their properties and the *degree of automation* of some of their properties. Our hypothesis is that a single type of capturing device with a set level of control is not sufficient to address the diverse needs when producing knowledge resources in fabrication workshops. Then, we run an online survey with 66 participants who report on their current capturing practices and, on how these unit types and their respective properties may suit their capturing needs. This chapter is based on an article published in CSCW'22 [108].

5.1. Design concept

The framework introduced in the Chapter 4 was about the analysis of existing systems. This chapter is about analysing potential *designs* of future systems. As the framework illustrates, the design space generated by the 5W+1H questions is enormous. We thus narrow our focus on visual capturing

5.1 Design concept	88
5.2 Study design	95
5.3 Findings	100
5.4 Discussion and Opportunities for Design	111
5.5 Conclusion	118

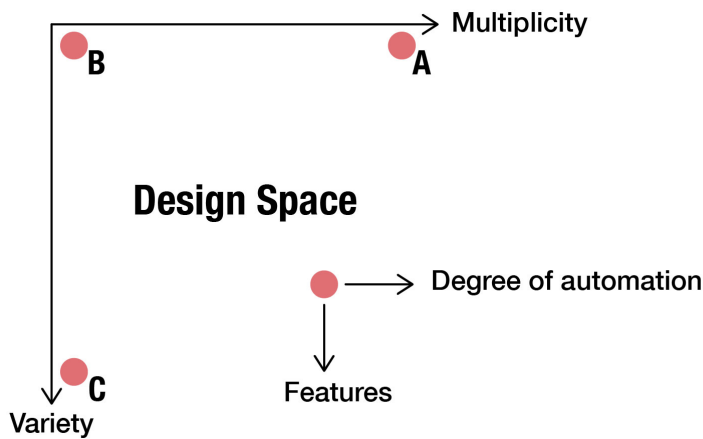

Figure 5.1: The design concept is exploring properties alongside two dimensions: multiplicity and variety of capture units.

(*What*), and particularly on three dimensions which emerged from the analysis of the framework: from the research direction “Supporting Diverse and Distributed Activities” we retain the (1) number of camera units and (2) the number of properties for each camera unit, and from the research direction “Exploring Automated versus User Control”, we retain (3) the degrees of automation of different properties.

5.1.1. Approach

The design space generated by the three dimensions: multiplicity, variety and degree of automation can be visualised following two axes: As shown Figure 5.1, the first axis is the multiplicity of capture units, the number of capture units, which goes from 1 (a single capture unit) to N capture units. The second axis is the variety of capture units, going from homogeneous capture units (all capture units have the same, determined configurations), to various capture units (captures units have different configurations). For each of the features of a given capture units (position, focus, zoom, meta-data collection, ...), a third axis describes their respective degree of automation.

In this design space, we imagine three extreme cases (A, B, C) as illustrated Figure 5.1.

First, we consider a system with *multiple* identical basic capture units (a simple camera) as shown in (A). Each capture unit is dedicated to a given location (station) and a given perspective. Given the distributed nature of the fabrication

activities and their diversity, this approach would require a large number of units and coordination between them (e.g., a maker would need to stop one and start another), or automation of properties.

The other extreme is to use a single, mobile camera that makers take with them (**B**), for example their smartphones. But as we have seen, this is cumbersome for the hands, or in the case of head-mounted glasses may not be suitable for all activities.

A third extreme case, (**C**), considers the *variety* of the configurations and their degrees of automation, where the system could be a single and re-configurable capture unit. However, the more properties to reconfigure, the more work and time the maker would spend on setting up the capture unit.

The third axis, describing the automation of properties, can be explored in the case of units featuring a big number of possible configurations that the maker must handle thyself. We could imagine an *intelligent* capture unit with *various* and *automated* properties offering the capacity to both determine and adopt the best configuration (e.g., location and orientation) depending on the activity, the maker, or the context. However, more intelligent systems require more powerful hardware, which risks being bulkier and which would likely only be available to more affluent workshops.

Between these 3 extreme cases, and their respective automated properties, is a rich space of possibilities which can be described by the mentioned three dimensions: *multiplicity* (number of camera units), *variety* (the different configurations for each unit type) and the respective *degree of automation* for each property. However, such a rich space is challenging to implement, and while evaluations with real physical prototypes are valuable when the concrete design choices for the implementation of these prototypes are clear, there is a risk of participants focusing on low-level implementation issues for cases where the possible design space is large. Greenberg and Buxton called this “local hill-climbing” [58] and emphasised, together with Tohidi et al. [127], the utility of “design sketches” which demonstrate some aspect but stay intentionally vague or non-committal on others.

Stability/Mobility (section 4.1)

The analysis of tools with our framework shows that there is a compromise between the stability offered by fixed captured tools and the mobility necessary for capturing diverse activities in the space.

Our approach is in line with their argument and similar to the one taken by Vitale, Odom and McGrenere [142], who upon describing their design space developed five design concepts and evaluated them with interviews only showing video sketches to participants. In our case, we use a design concept and a set of five conceptual units exemplifying areas within the design space. We also generated a video sketch to illustrate how these units could integrate in a fabrication workshop. We expect that the use of video sketches instead of actual prototypes reduces the risk of “local hill-climbing” as it has been used successfully in prior work [99, 142]. Similar to Vitale *et al.* [142] and Tohidi *et al.* [127], we include multiple unit sketches to give participants an idea of the breadth of the design space. While Vitale *et al.* base their findings on interviews, we use an online survey to reach a larger number of people.

5.1.2. Capush

We now describe our design concept called Capush to exemplify different areas of the design space: It considers a fleet of capture units (*multiplicity*) composed of different unit types with different properties (*variety*). Some of these properties can be automatised (*degree of automation*). We now detail the design concept.

Capture unit The focus is on visual capture, thus each capture unit needs to be equipped with a camera to capture images or videos (*what*) in high quality. A unit is meant to be affordable and easy to build, ideally using materials commonly available in fabrication workshops. It should also be light, small, and easily customisable and extendable. Because they are affordable, *multiple* capture units can be distributed in the fabrication workshops and make them accessible to all makers. Moreover, an incidental benefit is that distributed capture units throughout the space can attract the makers’ attention [72] and remind them to produce resources. Because they are light and small, makers can easily grab them and move them from one location to another one. Because they are customisable, it is possible to create different types of

unit with various properties to respond to the specificities of different activities.





Each capture unit should be connected to a local network to provide a centralised access to the control of the units and to have them put captured content directly in a local repository. All captured content should be automatically enriched with contextual meta-data, such as which unit recorded the content and where it was located (*what*). Such meta-data could then serve to enrich later knowledge resources generated with the captured material, for example, using (semi)automatic tools to generate such resources [26, 91, 135]. It can also be used for faceted search in captured material.

Properties Since we want units to be customisable, Capush is based on a set of properties with which a unit can be extended. In this chapter, we focus on four properties related to the dimensions of the framework. As illustrated in Table 5.1, all capture units capture the same content (*what*) but vary according to *where* they can be located (the environment, on a machine, or worn by someone), *how* they enable the capture and *who* controls each of the properties. In particular, *who* refers to the **degree of automation**: the position and/or orientation of a camera unit can either be controlled by the system (automatic) or a person (manual). Similarly, both the system and the user can initiate the capture of contextual meta-data. By combining the different properties, it is possible to derive a large variety of camera-based units.

5.1.3. Unit Types

We focus here on five unit types whose properties are summarised in Table 5.1. Figure 5.2 shows mockups of the different unit types and illustrates how they could be used. We also provide proof of concept and directions for implementing such system in Chapter A. These units aim to coexist in a fabrication workshop, each adapted to different activities. Below, we describe the functionalities of each of them.

Table 5.1.: Description of the five examples of camera units derived from Capush in terms of content captured (what), location (where): machine / environment / person, mobility and hand free properties (how) and levels of automation (who) (orientation, position, contextual content capture). For the who dimension, □ specifies whether the control is manual only and ■ whether the control can be manual and automated.

						
		Fixed	Pan-tilt	Clamp	Head-mounted	Table Bot
What		Pictures / Videos / Project IDs / Tools / machines / Locations				
Where	Environment	■	■	■		■
	User				■	
	Machine	■	■			
How	Mobile			■	■	■
	Hands free	■	■	■	■	■
Who	Contextual meta-data	■	■	■	■	■
	Orientation		■	■	■	■
	Position			□	□	■

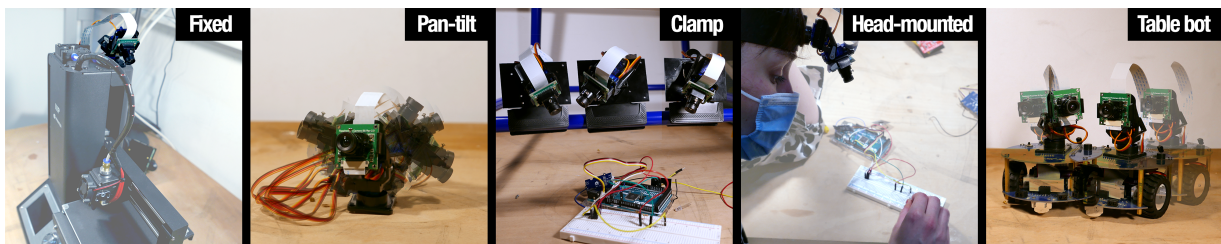

Figure 5.2.: Physical mockups of the five unit types: fixed, pan-tilt, clamp, head-mounted, and table bot.

Fixed camera

The fixed-camera unit is a camera attached (permanently) on a machine (such as a laser cutter) or a workstation (such as a soldering station) with a fixed, pre-determined viewpoint, focusing on the area of interest, such as a 3D printer bed, or a laser cutter work area.



Pan-tilt camera

The pan-tilt camera is an extension of the fixed camera. It is also installed permanently in the environment but its camera is mounted on a pan-tilt assembly enabling rotations around the pan and tilt axis for more control over the focus area. The control of the pan-tilt assembly can be automatic or manual. The latter lets makers control the orientation of the camera either through physical manipulations or through a (virtual) joystick interface displayed on a computer or smartphone's screen. Automatic control permits to track a specific tool or object while performing an activity, that is, objects of interest can remain in focus even if the makers move them. This approach is especially useful to capture a process including the displacement of pieces and tools on a workbench.



The three following units are mobile, enabling makers to freely transport and place them wherever they are working. While attached units can store their location as meta-data which only needs to be set once after installation, portable units need to be able to detect their location within a given space to provide this type of meta-data. We discuss how this could be achieved in Chapter A.

Clamp camera

A clamp camera is a mobile extension of the pan-tilt camera. It includes a battery pack and is mounted on a clamp, so that it can easily be moved and attached in the environment in different locations to get different points of view. This unit can thus be used to capture a scene from flexible points of view, providing makers with a quick and simple way to set up their scene.

*Head-mounted camera*

The head-mounted camera is an extension of the pan-tilt camera mounted on a headset, similar to the clamp but worn by a person, enabling a first person viewpoint capture. By attaching the unit once to the head, the maker can move around in the space wearing the head-mounted camera to go from an activity to another.

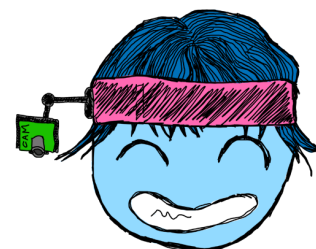
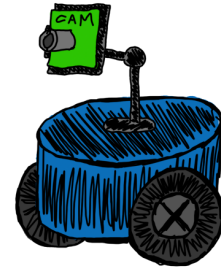

Table bot

Table bot is a Pan-tilt camera mounted on a small robot. Either the maker or the robot can decide the best position and orientation for this camera unit. In particular, the robot can track pieces (e.g. circuit board) or tools (solder) and move around on a table to maintain the distance between the objects of interest and the camera constant.

*Meta-data*

The concept of Capush includes a local repository where all captured content (pictures and videos) can be associated with tags. These tags can either be added by makers, for example, by entering a project name, the project owners' names or any annotation that makers may find useful. As these manual tag entries can require some effort from the maker, the concept includes the generation of automated meta-data as tags, including the location of the captured content (e.g., "woodworking area", "electronic workbench"), machines or tools identified in the stream (e.g., "screwdriver", "3D printer", "...), and timestamps.



5.2. Study design

We designed an online survey study to better understand current capturing practices in fabrication workshops, and to explore in how far the dimensions exemplified in the five unit types correspond to the capturing needs of makers. The goal of this study was also to identify challenges and to provide directions for which prototypes of the design concept should be developed further. The study received research ethics approval from the Research and Ethics Committee of our institution.

5.2.1. Research Questions

We designed our study with three guiding research questions in mind:

1. What are makers' current capturing practices across diverse activities?
2. How do makers envision the impact of the different dimensions of a shared capturing equipment's properties on their capturing practices?
3. What are the potential issues that need to be considered for different types of equipment?

5.2.2. Survey Design and Approach

We implemented the survey on a personal server running LimeSurvey 3.25.21 and structured it in four parts:

1. **Introduction.** The first page was dedicated to inform potential respondents about the purpose of the study and ask for their informed consent.
2. **Background and demographics.** The second page asked general questions concerning basic demographics (age group, country of residence, profession) as well as background information on how long they have been using shared fabrication workshops, what roles they have had in these spaces (maker, manager, teacher or instructor, other), what kind of activities they tend to do (such as electronics, 3D printing, woodworking, etc), and what their collaboration habits are.
3. **Current capturing practices** contained two pages. The first one focused on current capturing habits and asked what kind of tools respondents currently use, how they find their captured content again, how satisfied they are with their current habits, and if and where they share any captured content online. The following page focused on two of the activities respondents indicated on page 2 (background and demographics). These two activities were dynamically selected according to the frequency at which the respondent had indicated capturing content about. Respondents were then asked for each what kind of record they generate when doing that activity, whether they are more interested in capturing the process or the result, and what kind of problems they encounter when capturing content from these activities.

4. **Exploration of the design concept.** The last page explores the different aspects of our design concept and the compatibility with different types of activities. Respondents are first asked to watch a 3:23 min video¹ explaining the concept and unit types. In the video, the different concepts were presented one-by-one as low-fidelity animated drawings like those in subsection 5.1.3. We provide an example of the visual style of the video in Figure 5.3. Accompanying the visuals, a voice-over and subtitles describe how the units are supposed to work, including the different degrees of freedom of the actuated and mobile units, as well as the automated and manual tag entries with location of each unit and object detection and tracking. Mock-ups of the units (Figure 5.2) were also included to illustrate more concretely how the units could look like. Finally, the video introduced the idea of a local repository and the use of tags to retrieve the captured content. Respondents were then asked to express how much they like each property with the option to provide details for each. Then respondents indicated for one of the two activities used on the previous page, how having access to this envisioned system may or may not change how and what they would capture. The survey concluded with a few questions inquiring if they would want such a system to be installed in the workshop they frequent, if they would use it if it was installed there, and how they would personally improve it. Finally, we asked if they can think of situations where they would *not* want such a system, and offered space to leave further comments if they desired. The supplemental material includes the raw responses to the questions from this page.

1: The video is included in the supplemental material of the publication: ‘Exploring Capturing Approaches in Shared Fabrication Workshops’ [108] which is accessible on the [ACM Digital Library](#)

Based on piloting, we estimated that it would take between 10 and 20 minutes to fill the survey. However, we also noted that providing more details in the many optional free-text response fields could considerably increase response time. We therefore added a warning on the information sheet page to make potential respondents aware of this. Nonetheless, we observed that respondents spend considerably more time than we expected (mean time 25 minutes [22, 29 minutes, 95%

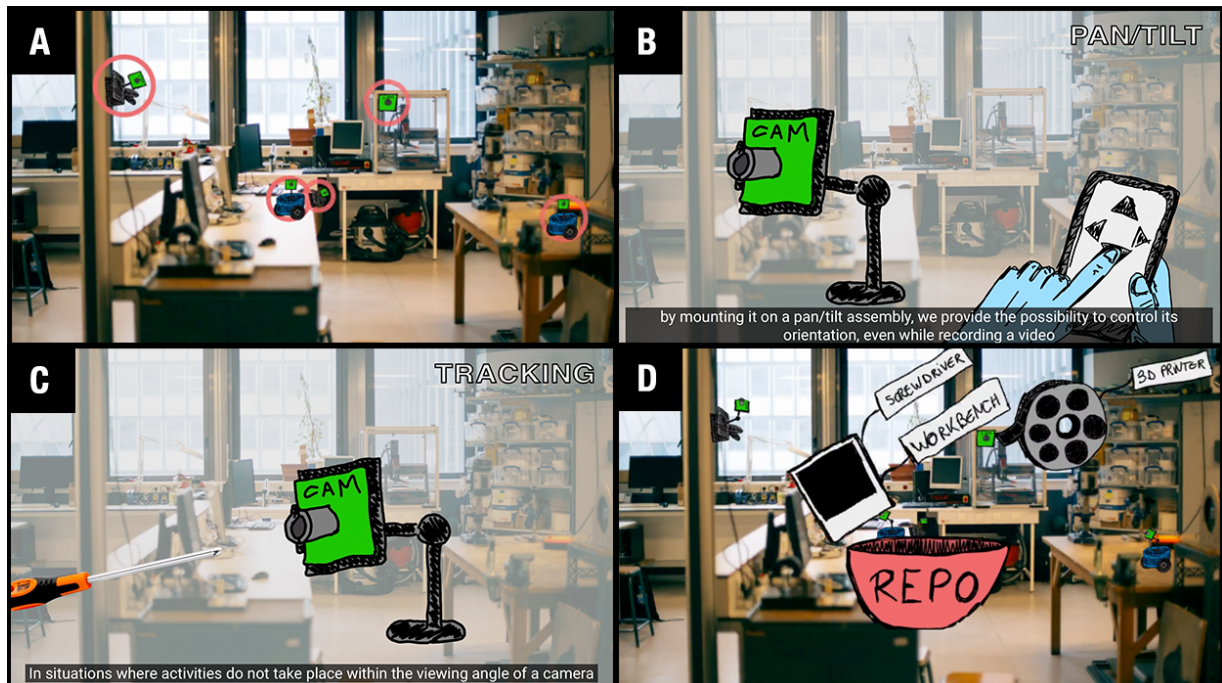

Figure 5.3.: Stills from the video shown to respondents. (A) shows the different units located in the workshop to illustrate multiplicity and variety. (B) illustrates the pan/tilt unit with manual control and (C) introduces automated position with tool tracking. (D) shows (conceptually) how the content captured from the units ends up in a local repository enriched with contextual meta-data (location, tool,...).

CI]).

5.2.3. Participant Recruitment

We aimed to reach a broad range of respondents and thus gathered emails from the [fablabs.io](https://www.fablabs.io)² website which includes people from all around the world. We sent out a total of 1,635 invitation emails, which resulted in 1,033 visits and 66 complete responses. The survey was available during 3 weeks. Figure 5.4 provides an overview of basic demographic information about the 66 respondents.

²: <https://www.fablabs.io>

5.2.4. Analysis and Report

The survey included a combination of questions where response options were either in the form of Likert items, multiple choice answers, or free text entry. We report responses to Likert items and multiple choice questions visually, in the form of bar charts for multiple choice questions and in the form of stacked, aligned bar charts for Likert items. Note that

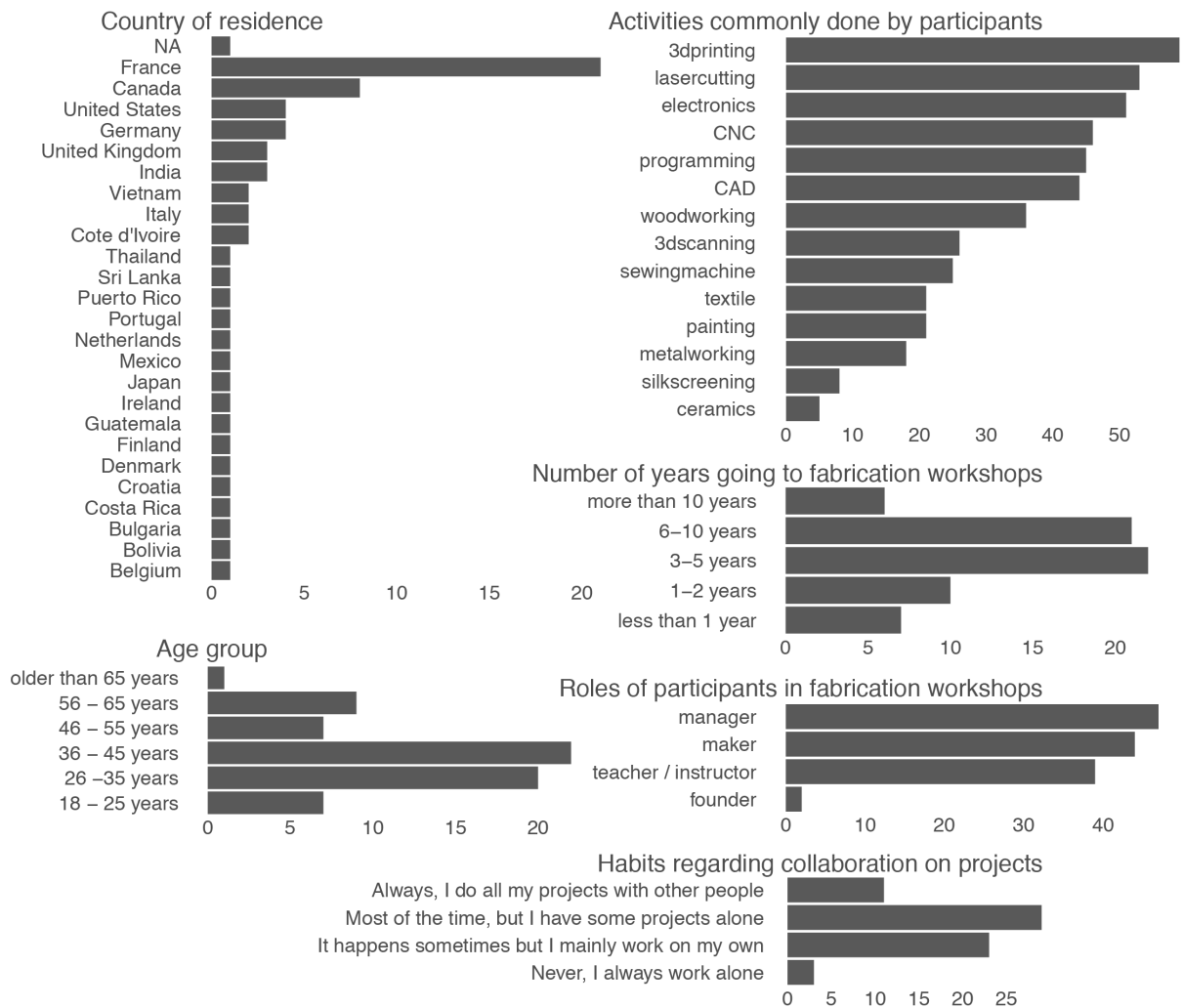

Figure 5.4.: Overview of demographics and background of our respondents.

the sum of responses to multiple choice questions sums up to more than the number of respondents. For Likert items, bars indicate percentages where all percentages are on the basis of the total number of respondents (66). Consequently, the sum of the stacked bars for one Likert item do not necessarily sum up to 100%. This is particularly the case for all questions broken down by activities, since any one participant was only asked in more detail about two activities for current practices and one in the context of Capush to keep the length of the survey manageable.

Free text responses were first categorised and classified by assigning codes in a spreadsheet. For each question, we extracted keywords or tendencies such as “positive/negative”, “manipulation”, “quality”, “privacy”. We then used these keywords to group the corresponding answers and refine the keywords.

For those text answers referring to two or more keyword groups, we simply copied them to the corresponding groups.

5.3. Findings

We report our findings in the same order as we formulated our research questions: (1) we describe participants' current practices and the tools they use to capture across diverse activities; (2) we detail how participants perceived and reported on the different properties of the design concept through the lens of our framework; (3) we compile issues and concerns reported by respondents. Underlined words refer to the dimensions of the framework presented in section 4.1.

5.3.1. RQ1: Current Capturing Practices

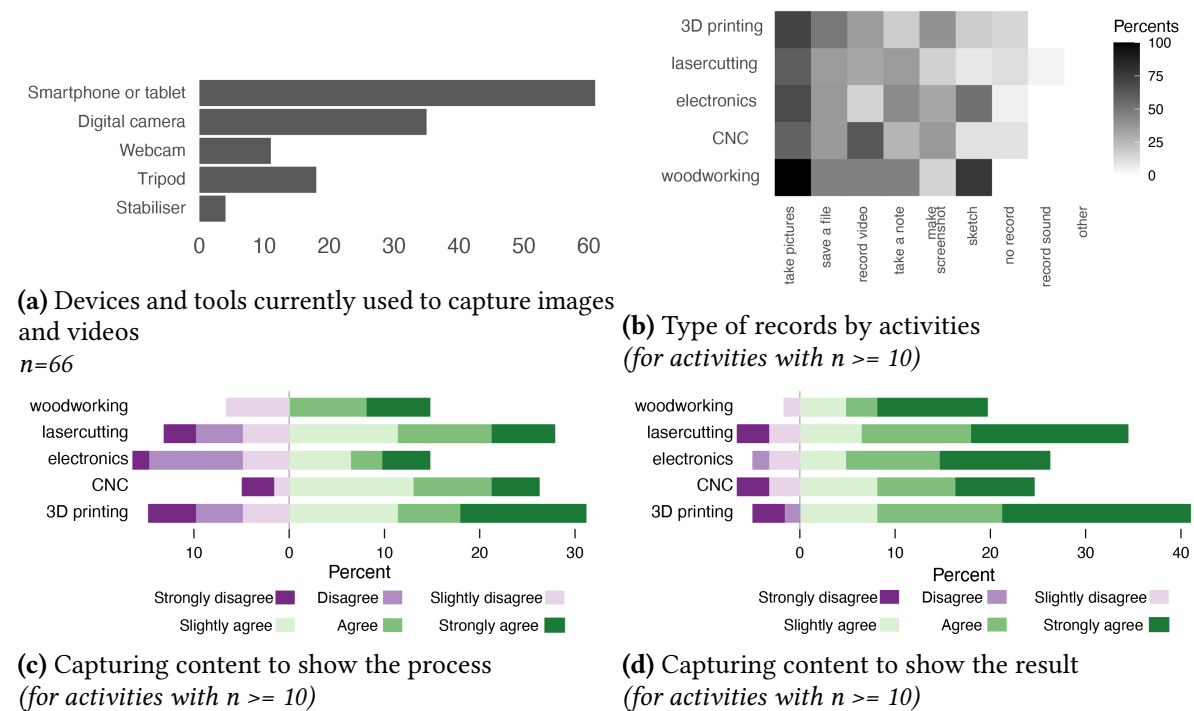

Figure 5.5.: Current practices in capturing content from fabrication activities
n(3dprinting)=28, n(lasercutting)=25, n(CNC)=19, n(electronics)=19, n(woodworking)=13

Our data confirm that almost all respondents use their personal devices such as smartphones or digital cameras, sometimes with tripods, to capture content as shown on Figure 5.5a

(How). They also confirm that pictures and videos play an important role when capturing content (*What*): Figure 5.5b shows that pictures are the most common capture format, followed by video across most activities. Respondents frequently save files as well and rather homogeneously across activities. For some activities, like woodworking or electronics, sketches are also somewhat frequent to keep, for instance, components and connections of electronic circuits (*“another easy and simple way to record and showcase the kinds of circuits I’m building”* - p8).

Only few respondents indicate that they are not used to capture anything to show the *result* (after the activity) Figure 5.5d. When asked if they are used to capture the *process* (during the activity), opinions diverge and depend much more on the actual activity. Those doing woodworking and CNC mostly are for capturing the process whereas respondents disagree on this for electronics, laser cutting and 3D printing. For instance, P15 takes pictures during 3D printing *“For documentation and communication and to keep track of the print’s quality”*, p62 takes pictures of all details involved in the woodworking process: *“pieces, cut pieces, pre-assembly, during glue up, clamp down, any mistakes made throughout the process, assembled piece before and after sanding and sealing”*.

In general, capturing images (pictures) appears more appropriate after the activity, for instance to *“record good samples or defect”* - p27 or to remember the montage in the case of electronics *“easiest means to record constructed circuits using physical components and breadboards”* - p8. In contrast, video capture appears more appropriate during the activity to record the process of e.g., 3D printing, laser-cutting or CNC (10 of 16 respondents). For instance, *“this is to show what happens in real time to others who want to know what 3D printing is like in real time (not static)”* - p8. When taking pictures during the activity, the purpose is then to keep track, record the iterations, and the methods as well as a mean for remembering the settings used.

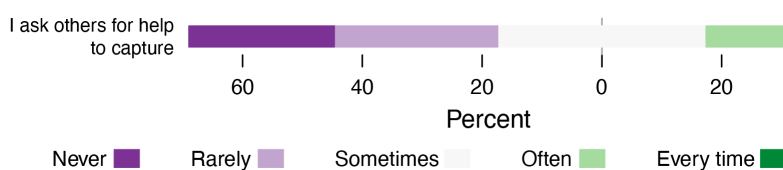

Figure 5.6.: Frequency of help solicited by respondents to capture images and videos.

Most respondents do not ask for help when they need to take a picture or record a video as shown in (Figure 5.6), however 23 of them gave examples of situations when capturing might be difficult. For instance, they may want to change the perspective to appear on the camera but cannot because their hands are busy and/or dirty. They also complained about the resolution of their devices or issues of the workshop environment such as bad lighting (e.g., protective glass reflecting the light on the machines), heat and wood chips, machines noises, vibrations and the need to protect the cameras against dirt. Some of them regretted that they did not have enough skills to capture nice content with nice angles. Finally, they mentioned forgetting to capture because of the switch between capturing and fabrication.

5.3.2. RQ2: Exploration of Framework Dimensions Through Capush

We now present the results relating to the the ways in which respondents would imagine using Capush to capture images and videos, and how it could influence their current practices. The results are organised according to the dimensions of our framework.

Why to capture

The survey did not contain a question asking explicitly about the reasons and motivations to create knowledge resources and if those would change with a system based on Capush. However, some respondents spontaneously commented about them, sometimes raising emerging opportunities. For instance, at the organisational level, 9 respondents (including 3 managers), mentioned that Capush could be used for safety and management purposes, providing *“Emergency Stop in case of fabrication problems. Give an advice when the part is fully processed. Send a message when the process is done”* - p19. P52 mentioned that it *“could be useful for safety purposes. For example showing machines unattended, safety guards not in operation”*. 4 respondents would use it to keep track of the visits, automatically identifying visitors, *“or presenting analytic data*

on the the use of the machines or the occupation level of the space” - p33. P11 also envisioned to locally showcase the captured content from different projects “[...] to teach others using the space and to inspire artists working at our lab” - p11.

Five respondents suggested potential benefits at the individual and community levels. Benefits include: automating content creation for diffusion to generate newsletters; making short summaries or accelerated video compilations (p19, p33 & p49); automatically send content to a wiki; “to enable keeping track” - p9 or to “automatically save pictures with machine setups in the wiki where we can add a comment” - p14.

What is captured

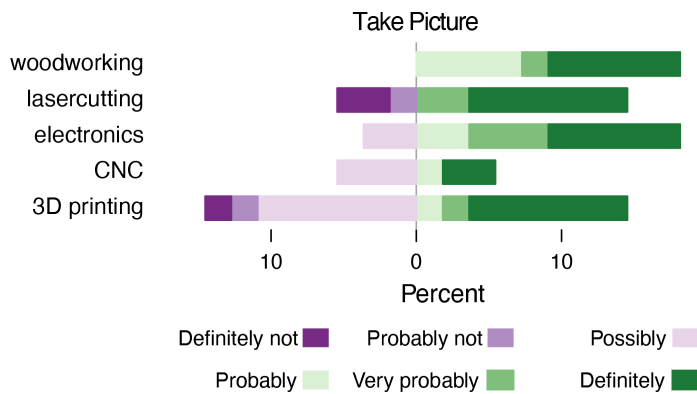

(a) Reported likelihoods of taking pictures for different types of activities.

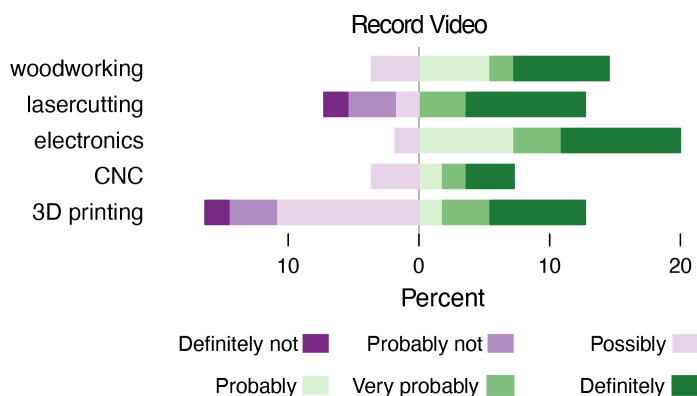

(b) Reported likelihoods of recording video for different types of activities.

Figure 5.7.: Reported likelihoods of taking pictures and recording videos with Capush depending on type of activity $n(3D\ printing)=16$, $n(lasercutting)=11$, $n(electronics)=12$, $n(CNC)=6$, $n(woodworking)=10$

Most respondents would take pictures with Capush for different kinds of activities as summarized in Figure 5.7a. Video capture (Figure 5.7b) is “more suitable for some steps of the

projects” - p43, “all of our actions would be recorded” - p6. Interestingly, 11 of the 12 respondents who considered Capush for the activity “electronic” would record videos with Capush, which was not the case when asked about their current practices (Figure 5.5b). Some respondents anticipate extending the kind of content they usually capture thanks to Capush (p21 & p24): “I think I would take *timelapse* videos of all my builds, if that would be very easy to do (only little time needed for setup etc)” - p21. Finally, respondents appreciated the possibility to associate meta-data (contextual information, tags) as illustrated in Figure 5.8 to simplify the organisation, the retrieval and the reuse of the content: “By typing the tag it would be easy to retrieve other projects using the same techniques, and eventually to find other strategies, also this would allow to retrieve one’s own work and to fill the wiki without searching/transferring all programs and pictures” - p9. “Having tags autoformatted would be terrific. It would also help me prove who created what” - p20.

Because respondents perceived Capush as undemanding and readily available, they envisioned capturing content more frequently: “If the system was set up and I used it, it would be much easier to capture [...] and I would probably take more photos” - p36. Capush also offers “more flexibility” - p16 to capture enabling better quality and richer content: “[It’s] a maker’s dream, it enables several angles and cameras attached at strategic places to create a beautiful montage of the creative process!” - p3. Two respondents also imagined to extend capture to non-physical activities by recording the computer’s screens with OBS³.

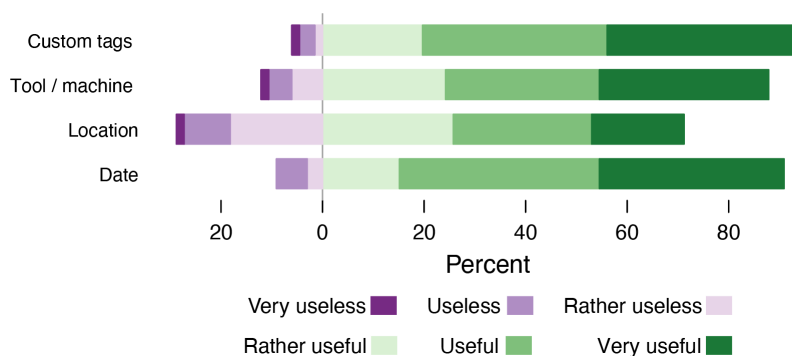

The survey software selected the two activities for which participants indicated capturing most frequently pictures or videos. Questions on current practices were asked for both activities, whereas exploration of Capush was focused on the first main activity. Consequently, out of the 49 people who indicated doing electronics (as shown in Figure 5.4), 19 were queried on their current habits regarding electronics (as shown in Figure 5.5) and only 12 were queried how Capush could be used to capture an electronics activity.

3: Open Broadcaster Software
<https://obsproject.com/fr>

Figure 5.8.: Reported usefulness for the 4 types of tags suggested: customs, tool/machine, location in the workshop, and date. $n=66$

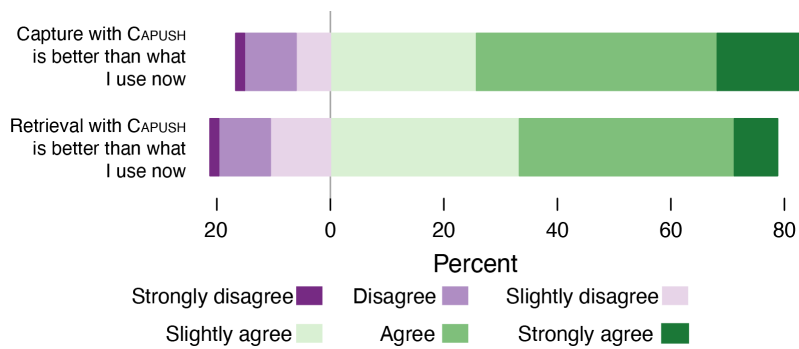

Figure 5.9.: Capture and retrieval better than current.
n=66

How to capture

A clear majority of respondents appreciated the concept of Capush to capture content (see Figure 5.9) and rated it as better than what they are currently using both concerning capturing itself and retrieving content from a shared repository. In particular, they appreciated not to have to use their own device and risk to break them: *“I don’t have space on me to carry a phone all the time; I don’t want to damage my own camera; it might be a good reminder to take process pictures”* - p62. However, other respondents also wished for openness, to be able to continue to use their personal devices and software tools together with Capush. P42 wanted to be able to connect the system they currently use in their workshop.

Similarly, p27 & p61 would like to use their smartphone or GoPros to take pictures with Capush through an app.

Concerning the variety of unit types, respondents showed a clear preference for both the fixed and the clamp camera over the head-mounted camera and the table bot (see Figure 5.10) suggesting that more complex unit types may not be necessary and that mobility and hands-free operation may be the decisive properties: *“we have several small rooms and a lot of machines, mobile cameras are useful”* - p24 although at least one respondent worried that the multiple mobile cameras such as the clamps would be cumbersome: *“it is annoying and you have to think of as many clamps as there are places where you want to attach it”* - p31. Finally, respondents seemed to appreciate the opportunity for hands-free manipulation given by the units, as P18 commented about the table-bot: *“I can imagine the use of such a device in the case of experiments where the practitioner has both hands busy”* - p18. About the head-mounted camera, P8 commented: *“handy, a bit invasive,*

but totally useful so I can continue to use my hands and still record all my work” - p8. Freeing up one’s hands might as well help makers to better focus on their work (p47).

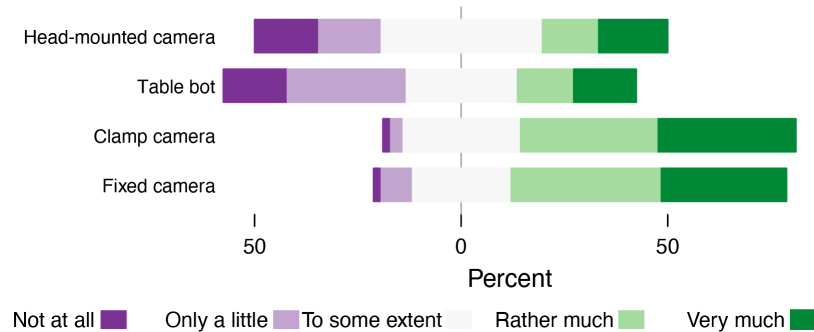

Figure 5.10.: Reported appreciation of the camera units of Capush.
n=66

When to capture

Respondents expressed a similar intent to capture more during (process) as well as after (result) the activity indicating that they expect the pure *presence* of capturing units to remind them to take pictures and videos and more generally to think about documenting their work. *“It might be a good reminder to take process pictures” - p62.* As Figure 5.11a and Figure 5.11b illustrate, this is especially the case for activities involving the use of tools. In addition, three respondents mentioned the advantage of a community capturing tool across the lifetime of a project.

“It would help me replicate my initial actions for future builds that need the same process it would be useful to have more information available to create a more effective narrative of what I did, when I did it, and how it would help others trying to replicate what I’m doing (if they are so interested)” - p8.

Where to capture

A fixed camera on machines was one of the preferred units because it is *“useful”* or *“interesting”* (7 respondents). 6 other respondents appreciated that it requires no effort to set up since it is already installed and that it would consequently make it easier and faster to record content from a machine. In particular, they mentioned that they would essentially

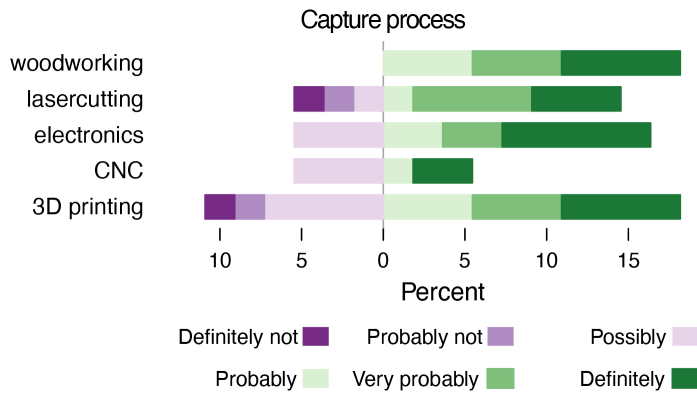

(a) Reported likelihood to capture process with Capush

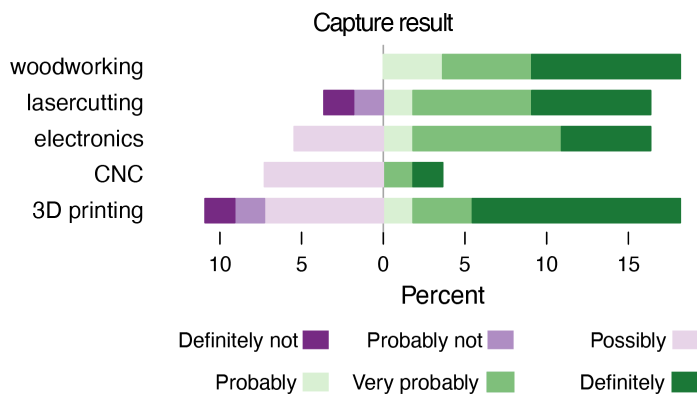

(b) Reported likelihood to capture the result with Capush

Figure 5.11.: Reported likelihood to capture the process and the result with Capush for activities where $n > 5$
 $n(3dprinting)=16$, $n(lasercutting)=11$, $n(CNC)=6$, $n(electronics)=12$, $n(woodworking)=10$.

capture videos or make timelapses of processes and manipulations: “it has the advantage of similar images from different stages” - p39.

Respondents also appreciated the clamp camera to position it in the environment and to adapt it to the scene: “it’s possible to attach it anywhere, good idea” - p9, giving examples of the case of “manual activities” - p14 or “activities where a fixed camera is not suitable” - p10. “It can create a multitude of angles to create interesting point of views” - p3.

The Table bot received mixed opinions because it seems unsuitable on cluttered desks and would require to free space, resulting in less spontaneity when capturing content. Some respondents also feared that the robot would get in the way of the primary activity and cause distraction. “I don’t want additional stuff on the work table, only gets in my way” - p21. P15 was more positive but would prefer an approach using

“a linear frame with a rotating head looking down toward the table”.

The head-mounted camera that makers wear (person) also received rather mixed opinions. On the positive side, some respondents appreciated that it offers a first person point of view and the possibility to free both hands while capturing. “This is probably the best way to capture what I am doing right in front my workbench/work surface” - p8. On the flip side, 15 respondents expressed concerns in their comments. A camera carried on the head might cause discomfort and, importantly, be incompatible with head-worn security equipment. Additionally, it would require special care and attention to avoid moving shots and blurry pictures which would result in extra work to remove them afterwards. It would “move too much” - p42, “make [me] seasick” - p9, and “require additional work to remove useless moving shots” - p24.

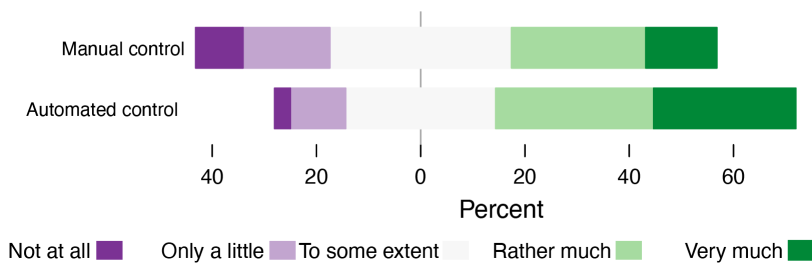

Figure 5.12.: Appreciation of the manual control vs automated control of the camera orientation. $n=66$

Who captures

Respondents tend to prefer the automated control of the camera orientation to the manual one with a joystick (see Figure 5.12). However, some respondents questioned the technical feasibility and reliability due to lighting, imagining a final result with possible “unstable videos” - p38 or “confusing shots” - p17.

In contrast, the joystick to manually control the camera orientation was perceived as “useless”, “too complicated” or “cumbersome”. Two respondents would rather move the camera with their hand directly: “we are not in a James Bond movie” - p31.

Regarding the automatic control of a camera’s position, respondents questioned the feasibility of programming a table bot capable to deal with a cluttered desk (see *Where*). The

autonomous locomotion might as well contribute to distraction as noticed by 4 respondents.

The way to trigger video/picture captures was not described in the concepts' presentation. However, two respondents (p10 & p25) spontaneously commented on the interest of adding an automatic trigger or offering an alert system to suggest to capture (p25) or trigger the capture via voice-command: "start tracking", "take a picture" - p4.

The concept includes to automatically upload the content captured from the different units to a local repository. Respondents indicated that this approach would be useful and save time (p17 & p42) because uploading and managing content is "tedious": "Getting the content from the phone to a useful place often doesn't happen" - p56, "Very useful for keeping stuff together and allowing ease of access" - p10. Nonetheless, some respondents did not find this approach essential and questioned how to manage access rights: "This can be useful or misused according to who is working with it. We had problems in one makerspace with the camera's, that led to a lot of power-gaming/headgames" - p35. "It will be useful but I wonder it could be more useful than Google photo" - p27.

The different contextual tags would help to retrieve and easily reuse the content (see *What*), but tagging all content can require a very good organisation and be cumbersome. "I'm too lazy to set them manually on my phone, makes it hard to find photos again" - p21. Providing automatic capture of meta-data as tags, including the location in the workshop, the machine and tools detected in the stream and timestamps, might solve this issue and was well received by respondents. "Automatic tags are awesome" - p21. "With the automatic tags, will save me time of doing it later in the computer and try to remember the details" - p48

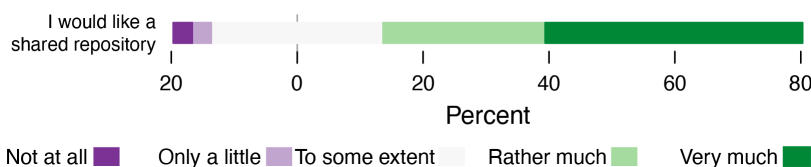

Figure 5.13.: Appreciation of a shared local repository with tags. $n=66$

5.3.3. RQ3: Potential Issues and Concerns

While a large majority of respondents would want a Capush system deployed in their workshop (Figure 5.14 and Figure 5.9), some respondents raised important concerns that any implementation of camera-based capture tools in fabrication workshops should take into account.

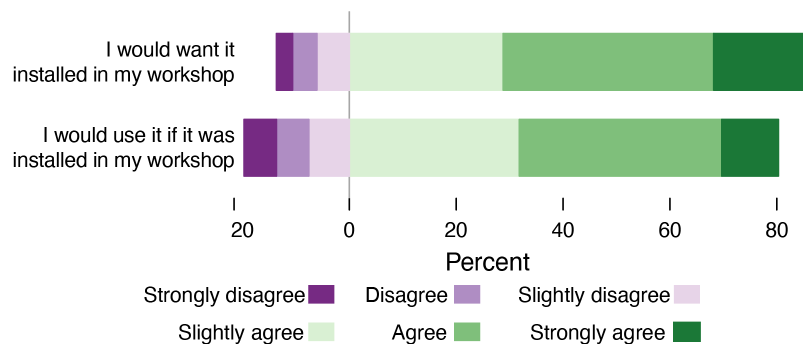

Figure 5.14.: Appreciation of the overall system.
n=66

Privacy

Some respondents suggested that consent from users of the workshop for being filmed should be explicitly gathered because some persons might feel uncomfortable (p13 & p16) or do not want to be filmed without knowing it (p44, p21, p34, p39 & p25): *“In case camera would capture other persons in the background, it would be hard to use, as some people strongly dislike the use of cameras at our fablab”* - p21. *“Maker-spaces know failure, meaning something can go wrong, even badly wrong. Simple mistakes can turn projects into smoke. This is something you don’t want to document on a personal record. If there are only friends, fine, but if there are others not friendly, bullying is an issue that should be avoided. A class situation [sic], where the attendance is not strictly voluntarily, could be awful once lesser skilled attendants turn their attention to these devices to tinker with them instead of paying attention.”* - p39. *“Part of the young people who come here are not comfortable with their self-image. I know that it would cause problems for some of them if they happened to be on videos, and maybe that the sole presence of cameras would make them uncomfortable”* - p16. Some respondents suggested that some spaces should remain entirely free of cameras (p10, p50 & p56).

Intellectual property

Respondents recommended to pay attention to intellectual property in the context of company projects (p20, p23, p62), artists rights (p52), theft (p11), or industry equipment (p63) because it might prevent the use of cameras if not strictly framed. A few mentioned there could be problems in the cases where makers do secret projects (p27), adult content (p26), or illegal content (p33). *“I’m concern about intellectual property when all files are shared by others especially when it’s businesses/companies/studios that operate out of a shared space, to have their property be easily viewed by others.”* - p62. *“Not everyone want to shared their projects, for example if they are purposely on the fringes of legality ”* - p33.

Safety

Some respondents questioned the safety of the Capush concept because the workshop is already full of machines (p37): *“Most of the options are based around devices that would get in the way of performing the activities, so are inherently unsafe, as any attention paid to the use of a camera is attention that is not being used indirectly for the activity, which is a bad way to operate when you are working with dangerous tools/materials..”* - p35.

5.4. Discussion and Opportunities for Design

We revisit now the two research directions explored through Capush and the survey study: “Multiplicity and variety of capture units” and “Degree of automation” before discussing privacy and ethics, two dimensions that emerged from our study.

5.4.1. Multiplicity and Variety of the Capturing Units

Our study explored how multiple and varied units could support the diverse and distributed nature of capturing activities. Regarding multiplicity, results suggest that this is indeed essential, as fabrication activities are distributed, and more available capture devices increase the opportunities for capturing content in various ways. Concerning variety, results are less straightforward. However, what we see as a new opportunity, is the ability to integrate makers' personal capture devices (*e.g.* smartphones) into Capush to leverage the unique aspects they bring.

Multiplicity Increases Capture Opportunities. The fact that there are multiple cameras increases capture opportunities, for several reasons. First, because ubiquitous cameras serve the purpose of acting as a reminder. This can mitigate one of the main barriers reported in literature [138, 151] and confirmed by respondents in our study, which is that capturing is difficult and often forgotten, as makers focus on tasks that are physical and often cognitively demanding. Beyond capturing more content during a project, more units support keeping track of the process of fabricating an artefact (P62, P9), reinforce re-usability (P14) and create better narratives (P3). This observation is in line with Gourlet et al. [55] who suggest that modularity is important when collecting traces of different activities at different stages of a process and Keune et al. [72] who encourage the salience of capturing devices meant for documentation. Second, because more capture units means that there are more angles and more locations (even inside machines) that are ready to be recorded without overhead. This facilitates capturing different perspectives simultaneously on the same artefact, which provides richer visual content for knowledge resources [40].

Limited Variety seems Sufficient. Many makers were sceptical about the usefulness of more complex unit types, that is, the head-mounted camera and the table bot, and feared they would be distracting or simply get in the way. At the

same time they appreciated for fixed cameras the simplicity (no setting up) and predictability of footage (always the exact same viewpoint (P39)) and for clamp cameras their flexibility (freely adjustable viewpoints (P3)). Thus, given our findings, these two unit types seem complementary and sufficient. There may be some need though for temporary contraptions to attach to units, for example, to protect a unit from dust or debris spit out by a machine (P62), or to adjust exposure levels to record special activities like welding.

Personal Device Integration. In our framework analysis, we observed that personal devices (*e.g.*, smartphones) are appreciated because they are readily available and familiar to the maker, something our study confirms. While most respondents expressed support for adding a community shared capturing tool to their workshop, some asked explicitly to keep such a system open to use other types of capturing devices, such as their smartphones or GoPro cameras, but such that the captured footage is treated in the same way, that is, added to the repository and enriched with contextual meta-data. This gives makers the ability to combine properties they value from Capush with specific capture requirements they may need (*e.g.* macro zoom, timelapse or snapchat filters). Beyond camera-based units, integration can also happen with other forms of content capture, such as screenshots (P33) or sketches, which participants highlighted as relevant (Figure 5.5b). Ideally, makers should be able to include any content type together with the picture and video content captured with Capush.

Opportunities for Design Capture tools should be considering multiple cameras distributed in space and enable straightforward integration of makers' own capturing devices for leveraging their unique capture capabilities. The main challenge is to reduce the required overhead (favour simplicity) and facilitate predictability of the outcome. Makers also produce other content types, besides pictures and videos, and some expressed interest to send everything to the same repository.

5.4.2. Degree of automation: Mixed-Initiative Content Capture

As expected, opinions and preferences diverged across participants when it came to delegating control. Balancing automatic and manual control is indeed challenging, specifically in maker spaces: Previous work already noted that automatic capture control generates a lot of data without certainty of what is being captured [72], while complete manual control can require too much of the maker's attention distracting them from the main task of making. We posit that delegating control in capture tools does not necessarily need to be all or nothing, but could follow a mixed-initiative approach aiming to maximise the benefits of both types of control [6]. In mixed-initiative control, the system and user both contribute to a task (in this case, controlling and parameterise the capture tool) in a flexible way, as they can delegate and take control as the task advances in order to contribute what each does best. Our study elicited considerations for delegating control to capture tools. We discuss these considerations regarding mixed-initiative: task interference and customisation granularity.

Task Interference. Automation can introduce unintended extraneous interference to the activity and output. We observe reluctance for automation due to the uncertainty of resulting behaviour and output. We believe that this can be mitigated by setting restrictions on automation. For instance, P15 suggested constraining locomotion of the tablebot to one dimension (T_x) instead of two (T_{xy}), while controlling when capture takes place. This alleviates the maker from remembering to move the unit, with a mix of control that mitigates potential interruptions of the activity as the maker can more easily predict the unit's behaviour (which parts of the workbench the camera can invade by potentially rolling over material), as well as output volume (keeping control of the amount of media generated). Another example is that automatic orientation was perceived as a potential source for unsteady shots (p38), but it could be interesting to explore in more detail if being able to control sub-parameters (e.g. movement speed) would lead to more certainty of output.

Lastly, interference introduced by automation is likely specific to a given task, and therefore systems cannot assume that one type of automation (*e.g.* unit movement) will necessarily interfere with work always in a given way.

Customisation granularity. Customisation at different degrees of granularity supports a varying level of experience and preferences. As capture tools grow in complexity, more and more elements will be available for control, including movement, orientation and position, as well as the moment of capture. We observe that makers' needs and preferences play an important role in composing the right mix. Previous work studying how people manage personal media has identified this [142], for example, if a person's career depends on these media, manual control is desired as the cognitive cost of capturing is outshined by the benefits of making sure the media will not be lost. To lower the complexity, capture tools could provide mixed-initiative customisation assistance (MICA) [19] to help makers navigate through complex customisation highly-granular options. Finally, we believe that reminding the user to exert manual control might be a better strategy than fully exercising control, for example by having the system provide recommendations on when to act (*e.g.* when to trigger capture).

Opportunities for Design Capture tools could let makers set constraints for automation *before* starting the activity, so that makers delegate control *during* the activity to the system in the way they want. Awareness of these parameters is key, *before* starting the task regarding what can be controlled and what will be the effects of setting parameters, helping users set their desired preferences. *During* the activity, systems should give feedback of automated parameters (*e.g.*, blue colour on the wheels that are controlled automatically) and when triggering capturing (*e.g.*, sound), both for the maker that set the parameters so that they do not forget, but also for other makers who might occupy a part of the fablab where the system is running. At the same time, feedforward is also promising to indicate which areas a device can occupy as it moves, and what areas are in its capture reach given

the selected set of automation, increasing predictability of output.

5.4.3. Social Context: Privacy and Ethics

Fabrication workshops have been already identified as socio-technical environments [66, 129], as cultures of making “*shape collaboration and the social organisation of work*” [111]. We argue that content capture, and thus knowledge production, can support and contribute to the construction of social activities. First, as resources for care practices that reflect makers’ ethics. Toombs, Bardzell and Bardzell [130] discuss the ethics of makers as a complex negotiation of a neo-libertarian ethos and care ethos. Captured content supports care practices both overt-explicit (e.g. helping others become more independent through sharing how a process is done correctly) and overt-implicit (e.g. increasing safety through content capture to monitor safe machine operation). Content can also help makers accrue social capital, through proof of activities and achievements, which contributes to the notion of the “self-made” ethos in the maker space. Second, for entrepreneurship. Hui and Gerber [66] discuss how physical, technological and online resources are leveraged to promote values associated with this goal, and help makers walk a path towards it. Thus, content can be used for cognitive apprenticeship—learning a task by observing expert behaviour [31]—by creating new opportunities and increasing reach to more apprentices. Also, it enables apprenticeship to take place offline: content can be made available on demand increasing the chances of watching experts work, as doing so by standing next to the expert is limited by scheduling and the available space in the workshop.

Despite contributing to social practices, content capture can have implications on privacy and ethics, potentially posing a threat to others’ intellectual property. Our study elicits how not only a system can unintendedly capture another person and their work without consent, but that the mere presence of the camera can put other makers in an awkward position of avoiding certain areas or avoiding conversations out of fear of being recorded. This is important as intellectual property is a

major concern for makers, and can be an extra barrier in documenting [151], and hacker ethics vary widely, from radical activists [124], to seeking peace through technology democratisation [81]. Responses indeed showed that the variety of people occupying the space have unique values and perceptions that nuance the concerns. We thus believe that capture and privacy are a relationship rather than a consequence, as they relate to factors such as the degree of acquaintance with the person being captured and the capture, the self-image of the captured person, or the level of choice a maker has (*e.g.* mandatory class attendance).

Opportunities for Design By considering privacy and ethics, a capture tool can contribute to social practices in fabrication workshops. We believe that ensuring visibility of on-going capturing activities and giving people control are two key aspects in capture tools that makers can use to tackle privacy. Regarding visibility, simple mechanisms such as a glow aura or line lasers showing the area captured provides others with awareness. In doing so, others can modify their behaviour to satisfy their needs and values regarding privacy for their ongoing activities. Moreover, a maker capturing content could be able to control the depth of a captured area, for example by setting the capture depth to a certain level (*e.g.*, no more than 1 meter) by relying on depth sensor information and blurring all areas considered background, or for cameras capable of setting a very narrow depth focus by simply setting it such that the foreground is in focus while blurring the background. More advanced mechanisms can provide finer control, such as blurring faces automatically if other makers walk into the frame. These measures are not exclusive, as the capture area can be exposed, limited, and still modified ex-post in case of unexpected appearances. Overall, while no one of our participants brought this up, moving from personal devices—which are omnipresent and for which a bystander generally cannot know if they are currently recording—to a shared community camera system could present an opportunity to develop systems which are respectful of privacy and put awareness and limitations in place to respect everybody's personal choices.

5.5. Conclusion

In this chapter, we have presented a design concept, Capush, based on the principle of multiple capture units collecting images, videos and contextual information, and varying in their degrees of freedom and automation. We also collected the perception of potential users of this tool design concept, while exploring the diversity of activities that each performs in the fabrication space. This provided us with new data on both the equipment needs of different user profiles and activities performed.

This study results in new opportunities for design, such as encouraging the multiplicity of capture units and their variety according to the activities, as well as automating certain properties of the capture to reduce the physical and cognitive costs. We also highlight the implications of such tools in the workshop setting, in particular, considering privacy and ethics by providing visibility and control of what is captured.

This chapter builds on all the results and new knowledge presented in the previous chapters. Thus, it constitutes the final point of the contributions of this thesis by directly informing the design for knowledge capture in the fabrication workshops. The work presented in this chapter does however have its limitations, and also opens up new research perspectives on capture tools. We discuss these in the next chapter.

Discussion, Future perspectives, and Conclusion

6.

During this thesis, my work was organised according to two main research questions, from which I aimed to address the design of tools to support makers in the creation of knowledge resources:

- ▶ What are the objectives of knowledge resources and the challenges faced by makers creating them?
- ▶ Which properties of a system matter to support makers in the capture of content from fabrication activities?

In this final chapter, I revisit these research questions. Then, I discuss how this work can be extended as short term perspectives, as well as the long term opportunities for research on knowledge capture and resource creation in fabrication workshops.

6.1. What are the objectives of knowledge resources and the challenges faced by makers creating them?

To inform the design of tools to be installed in a workshop, it was important to first understand the different objectives related to these knowledge resources and then to identify more precisely the challenges. My co-authors and I approached this research question from a literature review to considering both the different terminologies used, and the variety of research fields dealing with knowledge resources: education, design, fabrication *etc.*, leading to two main contributions: The first

6.1	What are the objectives of knowledge resources and the challenges faced by makers creating them? .	119
6.2	Which properties of a system matter to support makers in the capture of content from fabrication activities?	120
6.3	Short term perspectives	122
6.4	Long-term perspectives	124
6.5	Conclusion . . .	130

contribution is the identification of 4 objectives and 8 challenges associated with the creation of resources, and to note that these resources have the same objective: to represent a fabrication project, which exposes the makers to the same challenges regardless of other, more specific objectives. This analysis also shows that challenges specific to certain objectives are related to these transversal challenges. In particular, the level of detail included in the resources, the quality of the content, and the reflection on the work in progress are related to the challenges associated to the capture of content. Thus, supporting makers in this challenge may address other challenges as well.

The second contribution is a framework generated by this analysis, which allows to describe and compare different tools to support makers for the creation of knowledge resources on given objectives. Using this framework, we highlighted a set of strategies used by tools which leads us to identify key moments around which we provide examples of means to support makers. We conclude with guidance for the design.

We state that tools should:

- ▶ Support makers during content *capture*.
- ▶ Support makers through the different specific *objectives* and associated challenges while creating knowledge resources.
- ▶ Provide *interoperability* with tools specific to given objectives, in particular to disseminate and enable appropriation of the resource.
- ▶ Consider *automating* some of the stages of the resource creation.

6.2. Which properties of a system matter to support makers in the capture of content from fabrication activities?

At the very beginning of any knowledge resource is the capturing of material, that is, without capturing material, one

cannot create any kind of knowledge resource. Consequently, I narrowed the problem to the moment of content capture to understand its different aspects. First, by identifying the different dimensions of capture within the workshop, then by seeking to identify the practices of makers according to their activities in the workshop, and finally by studying the impact on the design of tools in fabrication workshops.

What are the different aspects of content capture in fabrication workshops?

Through a literature review, my co-authors and I proceeded to an analysis of the different aspects of content capture within the workshop. We find that content capture can be described through 6 dimensions: Why to capture, What to capture, How to capture, When to capture, Where to capture, Who captures, which allows to identify the different aspects of this complex task.

What are makers' current capturing practices during fabrication activities?

We explored this issue through an online questionnaire on capture habits. This confirms and deepens the understanding of some of the practices and challenges identified in the literature. Makers primarily use their phones to capture content, and are exposed to many barriers to capturing good quality content. But our results also nuanced some aspects, as the type of content captured may vary depending on the activity performed, and the time of the activity. Our results also highlighted the importance to consider the right to privacy and the need for agency over being recorded while being in a shared space.

How do the aspects of capture inform the properties of capture tools in fabrication workshops?

This questions has been approached in two ways. First, our analysis of the different dimensions of content capture generated a framework to describe and compare systems, and to identify under-explored dimensions. In particular, we have highlighted two research directions:

- ▶ Supporting capturing of diverse and distributed activities
- ▶ Exploring automation versus user control of content capture

Then, we explored these two research directions by focusing on the capture of visual information and contextual meta-data. For this, we proposed a design concept, Capush, built from the design space generated by these two research directions. We gathered the impression of makers about this design concept through an online questionnaire.

From this work, we provide the following opportunities for the design of capture tools:

- ▶ Consider multiple cameras distributed in the space.
- ▶ Provide variety in the capture units, including personal devices.
- ▶ Collect contextual-data and centralise the content in a repository to favour retrieval.
- ▶ Favour predictability and simplicity of the capture units, and visibility of what is captured.
- ▶ Provide control and awareness over the automated properties.

6.3. Short term perspectives

This work is subject to certain limitations. I detail here that the objectives, challenges and strategies identified deserve to be further explored, and that a field study on content capture using a version of Capush updated from our results should be done.

6.3.1. Refining the objectives, challenges and strategies identified

The corpus we collected during our literature review on knowledge resources contained only 36 articles. While this allowed the identification of a number of objectives and challenges, quantifying the emphasis put in the literature on the different objectives would be relevant. This is of course not an easy task to do since widening the search results in very large corpora. Should the currently developing AI tools become capable of analysing scientific literature (reliably), then a complete analysis of all work on the topic would become

possible. In addition, the literature-based approach could be complemented by a survey study to confirm or refine the objectives and challenges that makers may have in creating resources. That would need to be a quite large survey study with a stratified sample to make sure that different types of workshops and makers and from different continents/cultures are included.

Regarding the strategies identified to support makers, the main limitation is that we have discussed these strategies only from a selection of tools. In this regard, a more systematic collection of existing tools from the literature but also from products on the market would be necessary to ensure an exhaustive list of the different possible strategies to support makers' challenges.

As a mean to explore more strategies to support makers, it would also be interesting to consider the objectives, challenges and solutions brought by other domains, such as what can be found in industry [153], in art [88] or in research laboratories [122, 123]. For example, in the industrial context, resource creation is necessary for product life-cycle management (PLM) and traceability to ensure product quality and improve design [43]. The "Industry 4.0" paradigm is partly based on the creation and use of process data to ensure this traceability, using different tools such as the Internet of Things (IoT) or Cyber-Physical Systems (CPS), computers equipped with sensors and actuators, embedded in production lines [73]. Concepts of process representation such as digital twins in manufacturing, Building Information Modelling (BIM) in construction, ontologies, [48, 97] are very active research fields. The industrial domain is also interested in forms of learning in the organisation and how data capture tools can support this learning [18, 51]. Thus, the industry domain constitutes a field to be explored by its objectives of which at least some seem to overlap with those identified in this work, as well as the challenges and tools developed in the industrial context.

6.3.2. Studying the properties of Capush in the field

The findings reported in our study stem from an online survey evaluation based on a design concept introduced through a video. This approach has the advantage of facilitating the exploration of a diverse set of different units with various properties. An in-person evaluation using prototypes of these unit types runs the risk of participants focusing on smaller usability issues (depth first evaluation) instead of the breadth of unit types and how each of these may or may not be a suitable approach to capture content [58, 127]. However, our approach is not suitable to explore how actually using a unit would feel like and how it may alter the way people make things. Another limitation is that each respondent likely imagined details not made explicit in the video in a different way which may have increased noise in our data. In particular, we did not present explicit choices concerning the interactions to trigger the capture and control some features, and we did not consider the potential issues related to the need for light sources in certain configurations. While the approach enabled us to collect rich data to inform future research directions, an in-person study will still be necessary to validate how people's impressions and expectations compare with their actual behaviour when they are able to use a real system during their fabrication activities, ideally in the form of a field study and taking into account the insights gained from the reported study.

6.4. Long-term perspectives

Going further, one can imagine rich and diverse avenues for future work.

6.4.1. Further explore how automation of content capture and resource creation might benefit makers and the workshop

The question of automating knowledge resources has come up several times throughout this thesis. Automating can be a way to facilitate knowledge resource creation, and we have explored automation at the level of content capture. However, this aspect deserves to be explored more deeply, building on our exploration of content capture, as well as more broadly, considering automation of other stages of knowledge resource creation. These explorations should be considering the objectives and the role that knowledge resource creation can play in the work of the makers and for the fabrication workshop. I discuss possible explorations that can be made about automating capture, and the entire knowledge resources.

Automating visual content capture

Delegating the trigger of the capture of visual content to the system is probably not the most appropriate solution for several reasons: first, it leads to a large amount of—(mostly) useless—data that needs to be stored and curated. Second, this could lead to many problems related to privacy and intellectual property. Finally, automated capture of visual support material does not provide the opportunity for stepping back from the fabrication activity, and thus to *reflect during the work*. That being said, further research could explore how intelligent tools can automate content capture of visual content in certain cases, taking these issues into account.

Automating non-visual content capture

Our study showed interesting perspectives for capturing other types of data, in particular contextual data, for which automation seems to have a more direct interest: automated

collection of contextual meta-data about machines and location to generate tags and promote retrieval was positively perceived by the participants of our study. It would be interesting to study what data is of interest to be captured automatically or not, and how it can be used. Concerning the retrieval and reuse of the content captured by makers, we could imagine that these meta-data could be used to search in databases for related content, to suggest some solutions to one's current problems during the activity, or provide elements of inspirations to makers performing similar activities. We have also noticed through our analysis that the collection of contextual meta-data could be a way to provide an overview of the activities at the level of the workshop. For example, respondents from our study mentioned some opportunities for providing security warnings to the users of the machines currently used. The automatic capture of non-visual data thus constitutes an important research direction.

Full automation of the creation of knowledge resources

Several systems from the literature automate the creation of complete knowledge resources for very specific tasks by automatically recording author's events [28, 44, 59, 79] on a computer based activity, or in the case of fabrication activities such as assembly tasks [15, 137] for augmented reality tutorials. The latter implies to automate tracking of the location and position of the objects a maker interacts with by using Optitrack [146], tools recognition [29], or hand-tracking [36]. These techniques are difficult to generalise though, since they are constrained to a known environment and known objects, but the advances in computer vision and the availability of machine learning in object recognition could make the automated identification of objects, materials and tools more available in future years. Moreover, advances and democratisation of machine learning algorithms and generative AI with recent systems such as ChatGPT¹ suggest that very soon, it will be possible to easily generate appropriate resources from the captured visual and contextual content.

Thus, it might be possible to automate the whole knowledge resource creation process, however, it is important to consider

I provide a few examples of how I was able to interact with ChatGPT to ask information on how to perform fabrication projects and activities in Chapter B of the appendix.

1: <https://openai.com/blog/chatgpt>

the different objectives for the creation of these knowledge, in particular reflection and appropriation of the resources by the author. By automating the whole creation of knowledge resource, these benefits would probably be impossible, and a distant feeling from the final document might even lead the maker to not even interact with it at all. It could be thus interesting to investigate how full automation can still fulfill the needs for makers by studying how interaction with the automated process can be supported.

Parsimonious automation of the creation of knowledge resources

Another way to use automation could be not to automate everything, but instead to automate things that do not matter for learners and that we consider as obstructions to the workflow. A parsimonious automation in knowledge resource creation, can be a way to facilitate the maker's work while preserving the opportunity for reflection and appropriation.

Some works already go in that direction such as Document-While-Doing [91] and Protoboath [11] which process images or pre-create entries in resources that can later-on be enriched by the makers. In addition, both our analysis on tools to create knowledge resources in Chapter 3-section 3.3 and our study in Chapter 5 indicate that there are advantages in having a central system covering the capture and storage of content, as it enables automated upload of the content captured. Automated upload from the capture device to the device where the knowledge resource creation is authored, saves considerable time and effort to the maker [90, 102].

Automation of specific steps of the creation of resources opens perspectives that deserve further exploration, as it may help makers on the difficult and time consuming steps of the knowledge resource creation so they can focus on what matters at these moments.

6.4.2. Further explore how to extend capture tools

In this thesis, I have explored different properties of capture tools through the conceptual design of Capush. However, this exploration focused on 1) the capture of visual content and contextual meta-data, 2) the use by a single maker of the Capush device. This leads to several opportunities for further research, firstly concerning the types of content to capture, then concerning the way to control the features of capture tools.

Opportunities for the content captured

The dimension *What* kind of content is captured deserves further exploration by considering other kinds of content, including (1) the output of non-physical activities (e.g., programming or designing) that are not covered by Capush, such as code files, CAD files or sketches; and, (2) the parameters of machines and tools (e.g., Gcode), which could be saved and associated with the captured content. In addition, as mentioned above, content capture for organisational benefits has received less attention than for individual and community goals, and thus constitutes a promising research direction. Respondents in our study spontaneously described the interest of Capush for contributing to workshop management, for instance, by giving managers access to camera feeds from machines for security or maintenance purposes. Future research can explore how the design concept of Capush could be extended to these purposes, and studies will be needed to explore the acceptability of such organisational use of captured data, and how transparency about which data is collected and for which purposes could play a role in a system's acceptability.

Pursuing this idea, one could also explore adding a new "For Whom to Capture" dimension to our framework (section 4.1), allowing to describe perhaps more precisely the particular needs of an expert in comparison with those of a novice in their capturing practices. This dimension could also be used to explore the possible accessibility needs of each maker, for example young children, people with reduced mobility, visually impaired people, etc.

Opportunities for the control of the capture tool

In this thesis, we have explored the actuation of camera position and orientation and how it would be perceived by makers. Taking into account the results of our study, further research on the field deserves to be made at this level, as mentioned above.

Our work focused on the context of the fabrication workshop, but the actuation of the camera units could generate some opportunities in other contexts. In particular, in the case of remote learning, where teachers sometimes struggle to follow the activity of learners [78], actuation of the position and orientation of the camera units could be delegated to the teacher. This person could also be a manager inside the fabrication workshop, or a maker at home to follow the activity of a peer and collaborate. We can also see some opportunities due to the SARS-CoV-2 pandemic which saw most fabrication workshops closed for extended periods and large parts of the population constraint to their homes. Instructors who taught hands-on activities during this period were interviewed by Labrie et al. [78] and reported having difficulties to verbally indicate to the students to move the camera such as showing a part of the physical objects. We can imagine extending our design concept with connected units that could broadcast the streams of different students of a class to an instructor, and provide her with remote control access of the orientation or position of individual cameras to enable a better vision on the progress of students in real time. Therefore, there might be interesting paths to explore on automated camera movements and displacements to support *Reflection—IN—Action* and help remote instructors.

6.4.3. Further explore how to extend knowledge resource creation tools

This thesis has mainly focused on the properties of capture tools within the workshop. However, Chapter 3 has allowed us to highlight the need to allow makers to pursue different specific objectives, and thus a need to allow tools to be more interoperable with each other and with platforms specific to makers' uses. I believe that a generalisation of capture

tools, based on specific grammars for example fabrication grammars [128] and machine grammars [133], are directions to explore for building interoperable resource creation tools. In addition, the scope of our framework and concept is the context of a fabrication workshop. However it is interesting to reflect on the possibilities such a concept could generate outside the workshop as well. Using Capush across different fabrication workshops, by using similar units, and grammars, could enable to share and collaborate with different places, following the idea of Troxler and Zijp [134] with FabML.

6.5. Conclusion

In conclusion, this thesis contributes to a better understanding of the aspects of knowledge resource creation in the context of the fabrication workshop in order to inform the design of tools to assist makers in this task. This work generates many opportunities for tool design, and informs many research directions, in particular in an era where content sharing is at the centre of daily habits, and where automation and machine learning algorithms are becoming more and more powerful. Many opportunities remain to be explored to allow the learning and the diffusion of the knowledge related to fabrication techniques for all, and I am happy that my work by being part of this quest, can contribute to build more adapted tools for the makers wishing to participate in it.

Bibliography

- [1] A. Agirbas. ‘The Use of Digital Fabrication as a Sketching Tool in the Architectural Design Process’. In: *Proceedings of the International Conference on Education and Research in Computer Aided Architectural Design in Europe*. Vol. 2. Type: Conference Paper. 2015, pp. 319–324. DOI: [10.52842/conf.ecaade.2015.2.319](https://doi.org/10.52842/conf.ecaade.2015.2.319) (cit. on p. 20).
- [2] Maneesh Agrawala et al. ‘Designing Effective Step-by-Step Assembly Instructions’. In: *ACM SIGGRAPH 2003 Papers*. SIGGRAPH ’03. New York, NY, USA: Association for Computing Machinery, July 2003, pp. 828–837. DOI: [10/fbszp7](https://doi.org/10/fbszp7) (cit. on p. 70).
- [3] Shinya Aizu and Koji Tsukada. ‘Support System for Creating Manufacturing Manual using Smartwatches’. en. In: *Proceedings of the 2018 ACM International Joint Conference and 2018 International Symposium on Pervasive and Ubiquitous Computing and Wearable Computers*. Singapore Singapore: ACM, Oct. 2018, pp. 323–326. DOI: [10.1145/3267305.3267593](https://doi.org/10.1145/3267305.3267593) (cit. on pp. 76, 77).
- [4] Mina Akhavan. ‘Third Places for Work: A Multidisciplinary Review of the Literature on Coworking Spaces and Maker Spaces’. en. In: *New Workplaces—Location Patterns, Urban Effects and Development Trajectories*. Ed. by Ilaria Mariotti, Stefano Di Vita and Mina Akhavan. Series Title: Research for Development. Cham: Springer International Publishing, 2021, pp. 13–32. DOI: [10.1007/978-3-030-63443-8_2](https://doi.org/10.1007/978-3-030-63443-8_2) (cit. on p. 20).
- [5] Celena Alcock, Nathaniel Hudson and Parmit K. Chilana. ‘Barriers to Using, Customizing, and Printing 3D Designs on Thingiverse’. In: *Proceedings of the 19th International Conference on Supporting Group Work*. GROUP ’16. New York, NY, USA: Association for Computing Machinery, Nov. 2016, pp. 195–199. DOI: [10/ghd3mg](https://doi.org/10/ghd3mg) (cit. on p. 30).
- [6] J. E. Allen, C. I. Guinn and E. Horvtz. ‘Mixed-initiative interaction’. In: *IEEE Intelligent Systems and their Applications* 14.5 (Sept. 1999), pp. 14–23. DOI: [10/ch7j9k](https://doi.org/10/ch7j9k) (cit. on pp. 86, 114).
- [7] Gunnar Almevik, Patrik Jarefjäll and Otto Samuelsson. ‘augmented documentation methods to access traditional blacksmith skills’. en. In: (), p. 18 (cit. on p. 74).
- [8] Michelle Annett et al. ‘Exploring and Understanding the Role of Workshop Environments in Personal Fabrication Processes’. en. In: *ACM Transactions on Computer-Human Interaction* 26.2 (Mar. 2019), pp. 1–43. DOI: [10.1145/3301420](https://doi.org/10.1145/3301420) (cit. on pp. 3, 17, 19, 26, 27, 75, 85).
- [9] Ignacio Avellino et al. ‘Multimodal and Mixed Control of Robotic Endoscopes’. In: *Proceedings of the 2020 CHI Conference on Human Factors in Computing Systems*. CHI ’20. Honolulu, HI, USA: Association for Computing Machinery, Apr. 2020, pp. 1–14. DOI: [10/gn9346](https://doi.org/10/gn9346) (cit. on pp. 148, 149).

- [10] Christopher Baber. *Cognition and tool use: Forms of engagement in human and animal use of tools*. CRC Press, 2003 (cit. on p. 1).
- [11] Yazan A. M. Barhoush et al. ‘Capturing Prototype Progress in Digital Fabrication Education’. en. In: *Proceedings of the Design Society: International Conference on Engineering Design 1.1* (July 2019). Publisher: Cambridge University Press, pp. 469–478. DOI: [10.1017/dsi.2019.50](https://doi.org/10.1017/dsi.2019.50) (cit. on pp. 37, 42, 49, 51–55, 59, 73, 78, 79, 127).
- [12] Thomas Barrett et al. ‘A Review of University Maker Spaces’. en. In: *2015 ASEE Annual Conference and Exposition Proceedings*. Seattle, Washington: ASEE Conferences, June 2015, pp. 26.101.1–26.101.17. DOI: [10.18260/p.23442](https://doi.org/10.18260/p.23442) (cit. on pp. 16, 17).
- [13] Gökçe Elif Baykal et al. ‘What FabLearn talks about when talking about reflection – A systematic literature review’. en. In: *International Journal of Child-Computer Interaction* 28 (June 2021), p. 100256. DOI: [10.1016/j.ijccci.2021.100256](https://doi.org/10.1016/j.ijccci.2021.100256) (cit. on pp. 28, 69).
- [14] Michel Beaudouin-Lafon. ‘Instrumental Interaction: An Interaction Model for Designing Post-WIMP User Interfaces’. en. In: *Proceedings of the SIGCHI Conference on Human Factors in Computing Systems*. CHI ’00. event-place: The Hague, The Netherlands. New York, NY, USA: Association for Computing Machinery, 2000, pp. 446–453. DOI: [10.1145/332040.332473](https://doi.org/10.1145/332040.332473) (cit. on p. 148).
- [15] Lawrence Bergman et al. ‘DocWizards: a system for authoring follow-me documentation wizards’. en. In: *Proceedings of the 18th annual ACM symposium on User interface software and technology - UIST ’05*. Seattle, WA, USA: ACM Press, 2005, p. 191. DOI: [10.1145/1095034.1095067](https://doi.org/10.1145/1095034.1095067) (cit. on p. 126).
- [16] Marja Gabrielle Bertrand and Immaculate Kizito Namukasa. ‘Maker Education: Assessment, Documentation, and Sharing With a Wider Community’. en. In: *International Journal of Online Pedagogy and Course Design (IJOPCD)* 12.3 (2022). Publisher: IGI Global, pp. 1–12. DOI: [10.4018/IJOPCD.304083](https://doi.org/10.4018/IJOPCD.304083) (cit. on pp. 37, 42–44).
- [17] François Bottollier-Depois et al. ‘Etat des lieux et typologie des ateliers de fabrication numérique’. fr. In: (2014), p. 107 (cit. on pp. 16, 17, 20).
- [18] Jacob Brix. ‘Exploring knowledge creation processes as a source of organizational learning: A longitudinal case study of a public innovation project’. In: *Scandinavian Journal of Management* 33.2 (2017), pp. 113–127. DOI: [10.1016/j.scaman.2017.05.001](https://doi.org/10.1016/j.scaman.2017.05.001) (cit. on p. 123).
- [19] Andrea Bunt, Cristina Conati and Joanna McGrenere. ‘Supporting interface customization using a mixed-initiative approach’. In: *Proceedings of the 12th international conference on Intelligent user interfaces*. IUI ’07. New York, NY, USA: Association for Computing Machinery, Jan. 2007, pp. 92–101. DOI: [10.1145/1216295.1216317](https://doi.org/10.1145/1216295.1216317) (cit. on p. 115).

- [20] Daragh Byrne and Marti Louw. ‘Tools with Histories: Exploring NFC-Tagging to Support Hybrid Documentation Practices and Knowledge Discovery in Makerspaces’. en. In: *HCI International 2020 – Late Breaking Papers: Interaction, Knowledge and Social Media* 12427 (2020). Ed. by Constantine Stephanidis et al., pp. 51–67. DOI: [10.1007/978-3-030-60152-2_4](https://doi.org/10.1007/978-3-030-60152-2_4) (cit. on pp. 37, 42, 44, 61, 71, 72).
- [21] Bradley A. Camburn et al. ‘The Way Makers Prototype: Principles of DIY Design’. en. In: *Volume 7: 27th International Conference on Design Theory and Methodology*. Boston, Massachusetts, USA: American Society of Mechanical Engineers, Aug. 2015, V007T06A004. DOI: [10/ghd3p9](https://doi.org/10/ghd3p9) (cit. on p. 30).
- [22] Tim Campbell et al. *Towards Digital Apprenticeship: Wearable Activity Recognition in the Workshop Setting*. en. Tech. rep. UCB/EECS-2015-172. Electrical Engineering and Computer Sciences, University of California at Berkeley, 2015, p. 7 (cit. on pp. 69, 77).
- [23] Scott Carter, Laurent Denoue and Daniel Avrahami. ‘Documenting Physical Objects with Live Video and Object Detection’. en. In: *Proceedings of the 27th ACM International Conference on Multimedia*. Nice France: ACM, Oct. 2019, pp. 1032–1034. DOI: [10.1145/3343031.3350581](https://doi.org/10.1145/3343031.3350581) (cit. on p. 149).
- [24] Scott Carter et al. ‘Tools to support expository video capture and access’. en. In: *Education and Information Technologies* 19.3 (Sept. 2014), pp. 637–654. DOI: [10.1007/s10639-013-9276-6](https://doi.org/10.1007/s10639-013-9276-6) (cit. on pp. 29, 37, 39–42, 70).
- [25] Scott Carter et al. ‘Creating Tutorials with Web-Based Authoring and Heads-Up Capture’. In: *IEEE Pervasive Computing* 14.3 (July 2015), pp. 44–52. DOI: [10.1109/MPRV.2015.59](https://doi.org/10.1109/MPRV.2015.59) (cit. on pp. 37, 40, 42, 51–55, 70, 73, 76, 82).
- [26] Scott Carter et al. ‘Tools for online tutorials: comparing capture devices, tutorial representations, and access devices’. In: *arXiv:1801.08997 [cs]* (Jan. 2018). arXiv: 1801.08997 (cit. on pp. 70, 73, 75, 76, 78, 85, 92, 149).
- [27] Ricky Chen et al. ‘Probing Documentation Practices: Reflecting on Students’ Conceptions, Values, and Experiences with Documentation in Creative Inquiry’. en. In: *Creativity and Cognition*. CC ’21. event-place: Virtual Event, Italy. Virtual Event Italy: ACM, June 2021, pp. 1–1. DOI: [10.1145/3450741.3465391](https://doi.org/10.1145/3450741.3465391) (cit. on pp. 28, 37, 40–44).
- [28] Pei-Yu Chi et al. ‘MixT: automatic generation of step-by-step mixed media tutorials’. en. In: (Oct. 2012), p. 10 (cit. on p. 126).
- [29] Subramanian Chidambaram et al. ‘ProcessAR: An augmented reality-based tool to create in-situ procedural 2D/3D AR Instructions’. en. In: *Designing Interactive Systems Conference 2021*. Virtual Event USA: ACM, June 2021, pp. 234–249. DOI: [10.1145/3461778.3462126](https://doi.org/10.1145/3461778.3462126) (cit. on pp. 72, 126).

- [30] Konstantinos Chorianopoulos, Letizia Jaccheri and Alexander Salveson Nossun. ‘Creative and open software engineering practices and tools in maker community projects’. en. In: *Proceedings of the 4th ACM SIGCHI symposium on Engineering interactive computing systems - EICS '12*. Copenhagen, Denmark: ACM Press, 2012, p. 333. DOI: [10.1145/2305484.2305545](https://doi.org/10.1145/2305484.2305545) (cit. on p. 17).
- [31] Allan Collins and Manu Kapur. ‘Cognitive apprenticeship’. In: *The Cambridge Handbook of the Learning Sciences*. Ed. by R. Keith Sawyer. Cambridge: Cambridge University Press, 2014, pp. 109–127. DOI: [10.1017/CB09781139519526.008](https://doi.org/10.1017/CB09781139519526.008) (cit. on p. 116).
- [32] Peter Dalsgaard and Kim Halskov. ‘Reflective design documentation’. en. In: *Proceedings of the Designing Interactive Systems Conference on - DIS '12*. Newcastle Upon Tyne, United Kingdom: ACM Press, 2012, p. 428. DOI: [10.1145/2317956.2318020](https://doi.org/10.1145/2317956.2318020) (cit. on pp. 37, 39, 41–43, 47, 52–55, 59, 74).
- [33] *DIY Citizenship: Critical Making and Social Media*. en. Feb. 2014 (cit. on p. 13).
- [34] Dale Dougherty. ‘The Maker Movement’. en. In: *Innovations: Technology, Governance, Globalization 7.3* (July 2012), pp. 11–14. DOI: [10.1162/INOV_a_00135](https://doi.org/10.1162/INOV_a_00135) (cit. on pp. 2, 15).
- [35] Katrien Dreessen, Selina Schepers and Danny Leen. ‘From Hacking Things to Making Things. Rethinking making by supporting non-expert users in a FabLab.’ en. In: (2016), p. 18 (cit. on p. 26).
- [36] Daniel Eckhoff et al. ‘TutAR: augmented reality tutorials for hands-only procedures’. en. In: *Proceedings of the 16th ACM SIGGRAPH International Conference on Virtual-Reality Continuum and its Applications in Industry*. Tokyo Japan: ACM, Dec. 2018, pp. 1–3. DOI: [10.1145/3284398.3284399](https://doi.org/10.1145/3284398.3284399) (cit. on p. 126).
- [37] Árni Már Einarsson. ‘Crafting, connecting, and commoning in everyday maker projects’. en. In: *International Journal of Human-Computer Studies* 156 (Dec. 2021), p. 102715. DOI: [10.1016/j.ijhcs.2021.102715](https://doi.org/10.1016/j.ijhcs.2021.102715) (cit. on p. 26).
- [38] Árni Már Einarsson. ‘Sustaining Library Makerspaces: Perspectives on Participation, Expertise, and Embeddedness’. en. In: *The Library Quarterly* 91.2 (Apr. 2021). Type: Article, pp. 172–189. DOI: [10.1086/713050](https://doi.org/10.1086/713050) (cit. on pp. 37, 41, 44).
- [39] Árni Már Einarsson and Morten Hertzum. ‘Me-to-We Design: How Can a Makerspace Nurture the Building of a Collaborative Community?’ en. In: *Human-Computer Interaction – INTERACT 2021*. Ed. by Carmelo Ardito et al. Vol. 12932. Series Title: Lecture Notes in Computer Science. Cham: Springer International Publishing, 2021, pp. 702–711. DOI: [10.1007/978-3-030-85623-6_39](https://doi.org/10.1007/978-3-030-85623-6_39) (cit. on pp. 26, 27, 37, 40, 42, 44).

- [40] Jorgen F. Erichsen et al. 'Protobooth: gathering and analyzing data on prototyping in early-stage engineering design projects by digitally capturing physical prototypes'. en. In: *Artificial Intelligence for Engineering Design, Analysis and Manufacturing* 35.1 (Feb. 2021), pp. 65–80. DOI: [10.1017/S0890060420000414](https://doi.org/10.1017/S0890060420000414) (cit. on pp. 73, 77–79, 112).
- [41] Omid Etehadhi et al. 'Documented: Embedding Information onto and Retrieving Information from 3D Printed Objects'. en. In: *Proceedings of the 2021 CHI Conference on Human Factors in Computing Systems*. New York, NY, USA: ACM, May 2021, pp. 1–11. DOI: [10.1145/3411764.3445551](https://doi.org/10.1145/3411764.3445551) (cit. on pp. 37, 41, 42, 71, 72, 74).
- [42] Hannah Fehringer, Claudia Kaar and Christian Stary. 'Makerspaces in Academic Education: An Exploratory Analysis and Design Framework'. en. In: *2019 18th International Conference on Information Technology Based Higher Education and Training (ITHET)*. Magdeburg, Germany: IEEE, Sept. 2019, pp. 1–10. DOI: [10.1109/ITHET46829.2019.8937350](https://doi.org/10.1109/ITHET46829.2019.8937350) (cit. on p. 21).
- [43] Yixiong Feng et al. 'Data-driven product design toward intelligent manufacturing: A review'. en. In: *International Journal of Advanced Robotic Systems* 17.2 (Mar. 2020). Publisher: SAGE Publications, p. 1729881420911257. DOI: [10.1177/1729881420911257](https://doi.org/10.1177/1729881420911257) (cit. on p. 123).
- [44] Jennifer Fernquist, Tovi Grossman and George Fitzmaurice. 'Sketch-sketch revolution: an engaging tutorial system for guided sketching and application learning'. en. In: *Proceedings of the 24th annual ACM symposium on User interface software and technology - UIST '11*. Santa Barbara, California, USA: ACM Press, 2011, p. 373. DOI: [10.1145/2047196.2047245](https://doi.org/10.1145/2047196.2047245) (cit. on p. 126).
- [45] D. Fields. 'Communicating about computational thinking: understanding affordances of portfolios for assessing high school students' computational thinking and participation practices'. In: *Computer Science Education* 31.2 (2021), pp. 224–258. DOI: [10.1080/08993408.2020.1866933](https://doi.org/10.1080/08993408.2020.1866933) (cit. on pp. 20, 37, 39–42, 60).
- [46] K. Fleischmann. 'Making things in Fab Labs: a case study on sustainability and co-creation'. In: *Digital Creativity* 27.2 (2016). Type: Article, pp. 113–131. DOI: [10.1080/14626268.2015.1135809](https://doi.org/10.1080/14626268.2015.1135809) (cit. on pp. 17, 20).
- [47] Sarah Fox, Rachel Rose Ulgado and Daniela Rosner. 'Hacking Culture, Not Devices: Access and Recognition in Feminist Hackerspaces'. en. In: *Proceedings of the 18th ACM Conference on Computer Supported Cooperative Work & Social Computing - CSCW '15*. Vancouver, BC, Canada: ACM Press, 2015, pp. 56–68. DOI: [10/ghg78v](https://doi.org/10/ghg78v) (cit. on p. 20).
- [48] Alvaro Luis Fraga, Marcela Vegetti and Horacio Pascual Leone. 'Ontology-based solutions for interoperability among product lifecycle management systems: A systematic literature review'. In: *Journal of Industrial Information Integration* 20 (2020), p. 100176. DOI: [10.1016/j.jii.2020.100176](https://doi.org/10.1016/j.jii.2020.100176) (cit. on p. 123).

- [49] Michelle Gantt and Bonnie A. Nardi. ‘Gardeners and gurus: patterns of cooperation among CAD users’. en. In: *Proceedings of the SIGCHI conference on Human factors in computing systems - CHI '92*. Monterey, California, United States: ACM Press, 1992, pp. 107–117. DOI: [10.1145/142750.142767](https://doi.org/10.1145/142750.142767) (cit. on p. 27).
- [50] Neil Gershenfeld. ‘How to Make Almost Anything’. en. In: (2012), p. 16 (cit. on pp. 10, 15, 28).
- [51] Michail N. Giannakos, Patrick Mikalef and Ilias O. Pappas. ‘Systematic Literature Review of E-Learning Capabilities to Enhance Organizational Learning’. en. In: *Information Systems Frontiers 24.2* (Apr. 2022). Company: Springer Distributor: Springer Institution: Springer Label: Springer Number: 2 Publisher: Springer US, pp. 619–635. DOI: [10.1007/s10796-020-10097-2](https://doi.org/10.1007/s10796-020-10097-2) (cit. on p. 123).
- [52] Michael Gleicher and Andrew Witkin. ‘Through-the-lens camera control’. In: *Proceedings of the 19th annual conference on Computer graphics and interactive techniques. SIGGRAPH '92*. New York, NY, USA: Association for Computing Machinery, July 1992, pp. 331–340. DOI: [10.1145/133994.134088](https://doi.org/10.1145/133994.134088) (cit. on p. 148).
- [53] Jun Gong et al. ‘Instrumenting and Analyzing Fabrication Activities, Users, and Expertise’. en. In: *Proceedings of the 2019 CHI Conference on Human Factors in Computing Systems - CHI '19*. Glasgow, Scotland Uk: ACM Press, 2019, pp. 1–14. DOI: [10.1145/3290605.3300554](https://doi.org/10.1145/3290605.3300554) (cit. on pp. 69, 71, 75, 76).
- [54] Pauline Gourlet, Louis Eveillard and Ferdinand Dervieux. ‘The Research Diary, Supporting Pupils’ Reflective Thinking during Design Activities’. en. In: *Proceedings of the The 15th International Conference on Interaction Design and Children - IDC '16*. Manchester, United Kingdom: ACM Press, 2016, pp. 206–217. DOI: [10.1145/2930674.2930702](https://doi.org/10.1145/2930674.2930702) (cit. on pp. 37, 42, 58, 68, 69, 74).
- [55] Pauline Gourlet et al. ‘DoDoc: a Composite Interface that Supports Reflection-in-Action’. en. In: *Proceedings of the TEI '16: Tenth International Conference on Tangible, Embedded, and Embodied Interaction - TEI '16*. Eindhoven, Netherlands: ACM Press, 2016, pp. 316–323. DOI: [10.1145/2839462.2839506](https://doi.org/10.1145/2839462.2839506) (cit. on pp. 49, 52–55, 73, 75, 76, 78, 79, 82, 85, 112).
- [56] Bruna Goveia da Rocha, Janne Spork and Kristina Andersen. ‘Making Matters: Samples and Documentation in Digital Craftsmanship’. In: *Sixteenth International Conference on Tangible, Embedded, and Embodied Interaction. TEI '22*. New York, NY, USA: Association for Computing Machinery, Feb. 2022, pp. 1–10. DOI: [10.1145/3490149.3502261](https://doi.org/10.1145/3490149.3502261) (cit. on pp. 37, 39, 40, 43).
- [57] David Green and David Kirk. ‘Open Design, Inclusivity and the Intersections of Making’. en. In: *Proceedings of the 2018 Designing Interactive Systems Conference*. Hong Kong China: ACM, June 2018, pp. 173–186. DOI: [10/gh4qqr](https://doi.org/10/gh4qqr) (cit. on p. 20).

- [58] Saul Greenberg and Bill Buxton. ‘Usability Evaluation Considered Harmful (Some of the Time)’. In: *Proceedings of the SIGCHI Conference on Human Factors in Computing Systems*. CHI ’08. event-place: Florence, Italy. New York, NY, USA: Association for Computing Machinery, 2008, pp. 111–120. DOI: [10.1145/1357054.1357074](https://doi.org/10.1145/1357054.1357074) (cit. on pp. 90, 124).
- [59] Tovi Grossman, Justin Matejka and George Fitzmaurice. ‘Chronicle: capture, exploration, and playback of document workflow histories’. en. In: *Proceedings of the 23rd annual ACM symposium on User interface software and technology - UIST ’10*. New York, New York, USA: ACM Press, 2010, p. 143. DOI: [10/c643b2](https://doi.org/10/c643b2) (cit. on p. 126).
- [60] Ankit Gupta et al. ‘DuploTrack: a real-time system for authoring and guiding duplo block assembly’. en. In: *Proceedings of the 25th annual ACM symposium on User interface software and technology - UIST ’12*. Cambridge, Massachusetts, USA: ACM Press, 2012, p. 389. DOI: [10.1145/2380116.2380167](https://doi.org/10.1145/2380116.2380167) (cit. on p. 74).
- [61] Michael Haldrup, Mads Hoby and Nicolas Padfield. ‘The bizarre bazaar: FabLabs as hybrid hubs’. en. In: *CoDesign 14.4* (Oct. 2018), pp. 329–344. DOI: [10.1080/15710882.2017.1378684](https://doi.org/10.1080/15710882.2017.1378684) (cit. on pp. 26, 27).
- [62] Susan M. Harrison. ‘A Comparison of Still, Animated, or Nonillustrated on-Line Help with Written or Spoken Instructions in a Graphical User Interface’. In: *Proceedings of the SIGCHI Conference on Human Factors in Computing Systems*. CHI ’95. event-place: Denver, Colorado, USA. USA: ACM Press/Addison-Wesley Publishing Co., 1995, pp. 82–89. DOI: [10/c33p5n](https://doi.org/10/c33p5n) (cit. on p. 70).
- [63] Sabine Hielscher and Adrian Smith. *Community-Based Digital Fabrication Workshops: A Review of the Research Literature*. en. SSRN Scholarly Paper ID 2742121. Rochester, NY: Social Science Research Network, May 2014. DOI: [10.2139/ssrn.2742121](https://doi.org/10.2139/ssrn.2742121) (cit. on pp. 15, 16, 20, 21).
- [64] Gaoping Huang et al. ‘AdapTutAR: An Adaptive Tutoring System for Machine Tasks in Augmented Reality’. en. In: *Proceedings of the 2021 CHI Conference on Human Factors in Computing Systems*. Yokohama Japan: ACM, May 2021, pp. 1–15. DOI: [10/gkskzr](https://doi.org/10/gkskzr) (cit. on p. 71).
- [65] Nathaniel Hudson et al. ‘Investigating How Online Help and Learning Resources Support Children’s Use of 3D Design Software’. en. In: *Proceedings of the 2018 CHI Conference on Human Factors in Computing Systems*. Montreal QC Canada: ACM, Apr. 2018, pp. 1–14. DOI: [10.1145/3173574.3173831](https://doi.org/10.1145/3173574.3173831) (cit. on p. 37).
- [66] Julie S. Hui and Elizabeth M. Gerber. ‘Developing Makerspaces as Sites of Entrepreneurship’. en. In: *Proceedings of the 2017 ACM Conference on Computer Supported Cooperative Work and Social Computing*. Portland Oregon USA: ACM, Feb. 2017, pp. 2023–2038. DOI: [10.1145/2998181.2998264](https://doi.org/10.1145/2998181.2998264) (cit. on p. 116).
- [67] Derek Van Ittersum. ‘Craft and Narrative in DIY Instructions’. en. In: *Technical Communication Quarterly* 23.3 (July 2014), pp. 227–246. DOI: [10.1080/10572252.2013.798466](https://doi.org/10.1080/10572252.2013.798466) (cit. on pp. 28, 37, 74).

- [68] Tomasz Jaskiewicz et al. 'LEVERAGING PROTOTYPES TO SUPPORT SELF-DIRECTED SOCIAL LEARNING IN MAKERSPACES'. en. In: *DS 93: Proceedings of the 20th International Conference on Engineering and Product Design Education (E&PDE 2018)*, Dyson School of Engineering, Imperial College, London. 6th - 7th September 2018. London: the Design Society, 2018, pp. 430–435 (cit. on pp. 37, 42–44).
- [69] Ton de Jong and Monica G. M. Ferguson-Hessler. 'Types and qualities of knowledge'. en. In: *Educational Psychologist* (June 2010). Publisher: Lawrence Erlbaum Associates, Inc. DOI: [10.1207/s15326985ep3102_2](https://doi.org/10.1207/s15326985ep3102_2) (cit. on pp. 21–24, 70).
- [70] Anna Keune and Kylie Pepler. 'Maker Portfolios as Learning and Community-Building Tools Inside and Outside Makerspaces'. en. In: *Computer-Supported Collaborative Learning Conference, CSCL*. Vol. 2. CSCL. Publisher: Philadelphia, PA: International Society of the Learning Sciences. Philadelphia, Pennsylvania, US: Philadelphia, PA: International Society of the Learning Sciences., July 2017, pp. 545–548 (cit. on pp. 30, 37, 40, 43, 44, 74).
- [71] Anna Keune, Kylie Pepler and Maggie Dahn. 'Connected portfolios: open assessment practices for maker communities'. In: *Information and Learning Sciences* 123.7/8 (Jan. 2022). Publisher: Emerald Publishing Limited, pp. 462–481. DOI: [10.1108/ILS-03-2022-0029](https://doi.org/10.1108/ILS-03-2022-0029) (cit. on pp. 37, 42–44, 59, 61).
- [72] Anna Keune et al. *DIY Documentation Tools for Makers*. en. Pages: 6. 2015 (cit. on pp. 47, 48, 73, 75–77, 84, 91, 112, 114).
- [73] Cristina Orsolin Klingenberg, Marco Antônio Viana Borges and José Antônio Valle Antunes Jr. 'Industry 4.0 as a data-driven paradigm: a systematic literature review on technologies'. en. In: *Journal of Manufacturing Technology Management* 32.3 (June 2019). Publisher: Emerald Publishing Limited, pp. 570–592. DOI: [10.1108/JMTM-09-2018-0325](https://doi.org/10.1108/JMTM-09-2018-0325) (cit. on p. 123).
- [74] Jarrod Knibbe, Tovi Grossman and George Fitzmaurice. 'Smart Makerspace: An Immersive Instructional Space for Physical Tasks'. en. In: *Proceedings of the 2015 International Conference on Interactive Tabletops & Surfaces - ITS '15*. Madeira, Portugal: ACM Press, 2015, pp. 83–92. DOI: [10.1145/2817721.2817741](https://doi.org/10.1145/2817721.2817741) (cit. on pp. 69, 71).
- [75] Sampsa M I Kohtala et al. 'Augmenting Physical Prototype Activities in Early-Stage Product Development'. en. In: *Proceedings of NordDesign 2018*. Linköping, Sweden: the Design Society, 2018, p. 15 (cit. on pp. 71, 77–80).
- [76] Robert E. Kraut, Susan R. Fussell and Jane Siegel. 'Visual Information as a Conversational Resource in Collaborative Physical Tasks'. en. In: *Human-Computer Interaction* 18.1-2 (June 2003), pp. 13–49. DOI: [10.1207/S15327051HCI1812_2](https://doi.org/10.1207/S15327051HCI1812_2) (cit. on p. 76).

- [77] Stacey Kuznetsov and Eric Paulos. ‘Rise of the expert amateur: DIY projects, communities, and cultures’. en. In: *Proceedings of the 6th Nordic Conference on Human-Computer Interaction Extending Boundaries - NordiCHI '10*. Reykjavik, Iceland: ACM Press, 2010, p. 295. DOI: [10.1145/1868914.1868950](https://doi.org/10.1145/1868914.1868950) (cit. on pp. 29, 30, 37, 40, 43, 44, 68, 70).
- [78] Audrey Labrie et al. ‘Toward Video-Conferencing Tools for Hands-On Activities in Online Teaching’. en. In: *Proceedings of the ACM on Human-Computer Interaction* 6.GROUP (Jan. 2022), pp. 1–22. DOI: [10/gpbhgs](https://doi.org/10/gpbhgs) (cit. on p. 129).
- [79] Benjamin Lafreniere, Tovi Grossman and George Fitzmaurice. ‘Community enhanced tutorials: improving tutorials with multiple demonstrations’. en. In: *Proceedings of the SIGCHI Conference on Human Factors in Computing Systems*. Paris France: ACM, Apr. 2013, pp. 1779–1788. DOI: [10/gh2ggh](https://doi.org/10/gh2ggh) (cit. on p. 126).
- [80] Jean Lave and Etienne Wenger. *Situated learning: Legitimate peripheral participation*. Cambridge university press, 1991 (cit. on p. 1).
- [81] Steven Levy. *Hackers: Heroes of the computer revolution*. Vol. 14. New York, USA: Anchor Press/Doubleday Garden City, NY, 1984 (cit. on pp. 10–12, 117).
- [82] Lindsay Lindberg, Deborah Ann Fields and Yasmin B. Kafai. ‘STEAM Maker Education: Conceal/Reveal of Personal, Artistic and Computational Dimensions in High School Student Projects’. In: *Frontiers in Education* 5 (2020). DOI: [10.3389/feduc.2020.00051](https://doi.org/10.3389/feduc.2020.00051) (cit. on pp. 37, 42–44).
- [83] Anne-Li Lindgren. ‘Ethical Issues in Pedagogical Documentation: Representations of Children Through Digital Technology’. en. In: *International Journal of Early Childhood* 44.3 (Nov. 2012), pp. 327–340. DOI: [10.1007/s13158-012-0074-x](https://doi.org/10.1007/s13158-012-0074-x) (cit. on pp. 73, 76).
- [84] Thomas Ludwig et al. ‘Appropriating Digital Fabrication Technologies – A comparative study of two 3D Printing Communities’. en. In: *iConference 2015 Proceedings*. Newport Beach, California, USA: iSchools, 2015, p. 13 (cit. on pp. 37, 41, 43, 74).
- [85] Debora Lui, Deborah Fields and Yasmin Kafai. ‘Student Maker Portfolios: Promoting Computational Communication and Reflection in Crafting E-Textiles’. en. In: *Proceedings of FabLearn 2019*. FL2019. New York, NY, USA: Association for Computing Machinery, Mar. 2019, pp. 10–17. DOI: [10.1145/3311890.3311892](https://doi.org/10.1145/3311890.3311892) (cit. on pp. 20, 37, 39–41, 60).
- [86] Debora Lui et al. ‘Design Considerations for Capturing Computational Thinking Practices in High School Students’ Electronic Textile Portfolios’. en. In: (2018), p. 8 (cit. on p. 20).

- [87] Anu Maatta and Peter Troxler. ‘Developing open & distributed tools for Fablab project documentation’. en. In: *Proceedings of the 6th Open Knowledge Conference, OKCon 2011, Berlin, Germany, June 30 & July 1, 2011*. Ed. by Sebastian Hellmann et al. Vol. 739. CEUR Workshop Proceedings. Berlin, Germany: CEUR-WS.org, Jan. 2011, p. 5 (cit. on p. 69).
- [88] Anna Maarit Mäkelä and Nithikul Nimkulrat. ‘Reflection and Documentation in Practice-led Design Research’. en-US. In: *Nordes 0.4* (Mar. 2011). Number: 4 (cit. on p. 123).
- [89] J Marsh et al. *Makerspaces in the Early Years: A Literature Review. University of Sheffield. A MakeEY Project, 2017*. 2021 (cit. on pp. 20, 21).
- [90] Christian McKay et al. *A Networked Vision For Sharing And Documenting*. en. Pages: 4 Publication Title: MakerED: Open Portfolio Project Research Brief Series (Phase 1) Type: Research Brief. 2015 (cit. on p. 127).
- [91] Iván Sánchez Milara et al. ‘“Document-while-doing”: a documentation tool for Fab Lab environments’. en. In: *The Design Journal* 22.sup1 (Apr. 2019), pp. 2019–2030. DOI: [10.1080/14606925.2019.1594926](https://doi.org/10.1080/14606925.2019.1594926) (cit. on pp. 28, 37, 39–43, 51–55, 59, 68, 70, 73, 74, 76–78, 82, 85, 92, 127).
- [92] Brian O’Connell. ‘Design and Analysis of an IoT Usage Tracking and Equipment Management System Within a University Makerspace’. en. PhD Thesis. Medford, Massachusetts, 2017 (cit. on pp. 69, 83).
- [93] Kenneth Page Oakley. *Man the tool-maker*. University of Chicago Press, 1964 (cit. on p. 1).
- [94] Lora Oehlberg, Wesley Willett and Wendy E. Mackay. ‘Patterns of Physical Design Remixing in Online Maker Communities’. en. In: *Proceedings of the 33rd Annual ACM Conference on Human Factors in Computing Systems*. CHI ’15. New York, NY, USA: Association for Computing Machinery, Apr. 2015, pp. 639–648. DOI: [10.1145/2702123.2702175](https://doi.org/10.1145/2702123.2702175) (cit. on pp. 37, 41, 44, 67).
- [95] Ramon Oldenburg and Dennis Brissett. ‘The third place’. en. In: *Qualitative Sociology* 5.4 (1982), pp. 265–284. DOI: [10.1007/BF00986754](https://doi.org/10.1007/BF00986754) (cit. on p. 20).
- [96] Kevin M. Oliver et al. ‘Informing Makerspace Outcomes Through a Linguistic Analysis of Written and Video-Recorded Project Assessments’. en. In: *International Journal of Science and Mathematics Education* 19.2 (Feb. 2021), pp. 333–354. DOI: [10.1007/s10763-020-10060-2](https://doi.org/10.1007/s10763-020-10060-2) (cit. on pp. 37, 60).
- [97] J. Neil Otte et al. ‘An ontological approach to representing the product life cycle’. en. In: *Applied Ontology* 14.2 (Jan. 2019). Publisher: IOS Press, pp. 179–197. DOI: [10.3233/A0-190210](https://doi.org/10.3233/A0-190210) (cit. on p. 123).

- [98] Sofia Papavlasopoulou, Michail N. Giannakos and Letizia Jaccheri. ‘Empirical studies on the Maker Movement, a promising approach to learning: A literature review’. en. In: *Entertainment Computing* 18 (Jan. 2017), pp. 57–78. DOI: [10.1016/j.entcom.2016.09.002](https://doi.org/10.1016/j.entcom.2016.09.002) (cit. on pp. 17, 20).
- [99] Esben W. Pedersen, Sriram Subramanian and Kasper Hornbæk. ‘Is my phone alive? a large-scale study of shape change in handheld devices using videos’. In: *Proceedings of the SIGCHI Conference on Human Factors in Computing Systems*. CHI ’14. New York, NY, USA: Association for Computing Machinery, Apr. 2014, pp. 2579–2588. DOI: [10.1145/2556288.2557018](https://doi.org/10.1145/2556288.2557018) (cit. on p. 91).
- [100] Kylie Pepler and Sophia Bender. ‘Maker Movement Spreads Innovation One Project at a Time’. en. In: *Phi Delta Kappan* 95.3 (Nov. 2013), pp. 22–27. DOI: [10.1177/003172171309500306](https://doi.org/10.1177/003172171309500306) (cit. on pp. 15–17, 20, 26, 29, 30).
- [101] Kylie Pepler and Anna Keune. “‘It helps create and enhance a community’”: Youth motivations for making portfolios’. en. In: *Mind, Culture, and Activity* 26.3 (July 2019). Type: Article, pp. 234–248. DOI: [10.1080/10749039.2019.1647546](https://doi.org/10.1080/10749039.2019.1647546) (cit. on pp. 37, 43, 44, 61, 68, 73).
- [102] Kylie Pepler et al. *SURVEY OF MAKERSPACES, PART III*. en. 2015 (cit. on pp. 27, 29, 45, 127).
- [103] Kylie Pepler et al. *SURVEY OF ASSESSMENT IN MAKERSPACES*. en. 2018 (cit. on pp. 17, 68).
- [104] Thorsten Prante et al. ‘Exploiting Context Histories: A Cross-Tool and Cross-Device Approach to Reduce Compartmentalization when Going Back’. en. In: *Informatik 2004 – Informatik verbindet – Band 1, Beiträge der 34. Jahrestagung der Gesellschaft für Informatik e.V. (GI)*. Ed. by Peter Dadam and Manfred Reichert. Bonn: Gesellschaft für Informatik e.V., Jan. 2004, pp. 314–318 (cit. on p. 71).
- [105] Clara Rigaud. ‘From the Makerspace to the Web: Creating Knowledge Resources from Fabrication Activities’. In: *Sixteenth International Conference on Tangible, Embedded, and Embodied Interaction*. TEI ’22. New York, NY, USA: Association for Computing Machinery, Feb. 2022, pp. 1–5. DOI: [10.1145/3490149.3503584](https://doi.org/10.1145/3490149.3503584) (cit. on p. vii).
- [106] Clara Rigaud, Gilles Bailly and Yvonne Jansen. ‘Ressources de connaissances dans les ateliers de fabrication : objectifs et défis’. fr. In: *IHM ’23: Proceedings of the 34th Conference on l’Interaction Humain-Machine*. Troyes: ACM, Apr. 2023. DOI: [10.1145/3583961.3583974](https://doi.org/10.1145/3583961.3583974) (cit. on pp. vii, 33).
- [107] Clara Rigaud, Yvonne Jansen and Gilles Bailly. *Automating Documentation Considered Harmful (Some of the Time)*. en. Apr. 2022 (cit. on p. vii).
- [108] Clara Rigaud et al. ‘Exploring Capturing Approaches in Shared Fabrication Workshops: Current Practice and Opportunities’. In: *Proceedings of the ACM on Human-Computer Interaction* 6.CSCW2 (Nov. 2022), 391:1–391:33. DOI: [10.1145/3555116](https://doi.org/10.1145/3555116) (cit. on pp. vii, 65, 88, 97).

- [109] David Roedl, Shaowen Bardzell and Jeffrey Bardzell. 'Sustainable Making? Balancing Optimism and Criticism in HCI Discourse'. en. In: *ACM Transactions on Computer-Human Interaction* 22.3 (June 2015), pp. 1–27. DOI: [10.1145/2699742](https://doi.org/10.1145/2699742) (cit. on p. 20).
- [110] Daniela Rosner and Jonathan Bean. 'Learning from IKEA Hacking: I'm Not One to Decoupage a Tabletop and Call It a Day.' en. In: *Proceedings of the SIGCHI Conference on Human Factors in Computing Systems*. CHI '09. event-place: Boston, MA, USA. New York, NY, USA: Association for Computing Machinery, 2009, pp. 419–422. DOI: [10.1145/1518701.1518768](https://doi.org/10.1145/1518701.1518768) (cit. on p. 68).
- [111] Daniela K. Rosner et al. 'Making cultures: building things & building communities'. In: *Proceedings of the companion publication of the 17th ACM conference on Computer supported cooperative work & social computing*. CSCW Companion '14. New York, NY, USA: Association for Computing Machinery, Feb. 2014, pp. 113–116. DOI: [10.1145/2556420.2556852](https://doi.org/10.1145/2556420.2556852) (cit. on p. 116).
- [112] Jessica Schoffelen and Liesbeth Huybrechts. 'Sharing is caring. Sharing and documenting complex participatory projects to enable generative participation'. en. In: *IxD&A* 18.18 (2013), pp. 9–22 (cit. on pp. 28, 67).
- [113] Donald A Schon. *The reflective practitioner: How professionals think in action*. Vol. 5126. Basic books, 1984 (cit. on pp. 68, 69).
- [114] Eldon Schoop et al. 'Drill Sergeant: Supporting Physical Construction Projects through an Ecosystem of Augmented Tools'. en. In: *Proceedings of the 2016 CHI Conference Extended Abstracts on Human Factors in Computing Systems - CHI EA '16*. San Jose, California, USA: ACM Press, 2016, pp. 1607–1614. DOI: [10.1145/2851581.2892429](https://doi.org/10.1145/2851581.2892429) (cit. on p. 71).
- [115] JunHao Shan and Wei Wang. 'Making and sharing in asynchronous discussion: exploring the collaboration process in online maker community'. en. In: *Interactive Learning Environments* 0.0 (Apr. 2021). Type: Article, pp. 1–15. DOI: [10.1080/10494820.2021.1916764](https://doi.org/10.1080/10494820.2021.1916764) (cit. on pp. 29, 30, 37, 42–44).
- [116] Gautam Sharma. 'The Makerspace Phenomenon: A Bibliometric Review of Literature (2012–2020)'. en. In: *International Journal of Innovation and Technology Management* 18.03 (May 2021), p. 2150006. DOI: [10.1142/S0219877021500061](https://doi.org/10.1142/S0219877021500061) (cit. on p. 20).
- [117] Kimberly Sheridan et al. 'Learning in the Making: A Comparative Case Study of Three Makerspaces'. en. In: *Harvard Educational Review* 84.4 (Dec. 2014), pp. 505–531. DOI: [10.17763/haer.84.4.brr34733723j648u](https://doi.org/10.17763/haer.84.4.brr34733723j648u) (cit. on p. 20).
- [118] Heikki Sjomani et al. 'Effortless capture of design output a prerequisite for building a design repository with quantified design output'. en-US. In: *2017 International Conference on Engineering, Technology and Innovation (ICE/ITMC)*. Funchal: IEEE, June 2017, pp. 564–570. DOI: [10.1109/ICE.2017.8279935](https://doi.org/10.1109/ICE.2017.8279935) (cit. on p. 77).

- [119] Min Jeong Song. ‘Craftspeople’s new identity: The impact of digital fabrication technologies on craft practices’. en. In: *International Journal of Technology and Design Education* 32.4 (Sept. 2022), pp. 2365–2383. DOI: [10.1007/s10798-021-09687-1](https://doi.org/10.1007/s10798-021-09687-1) (cit. on p. 21).
- [120] Sohail Ahmed Soomro, Hernan Casakin and Georgi V. Georgiev. ‘A Systematic Review on FabLab Environments and Creativity: Implications for Design’. en. In: *Buildings* 12.6 (June 2022). Number: 6 Publisher: Multidisciplinary Digital Publishing Institute, p. 804. DOI: [10.3390/buildings12060804](https://doi.org/10.3390/buildings12060804) (cit. on p. 20).
- [121] Sohail Ahmed Soomro et al. ‘Tools for recording prototyping activities and quantifying corresponding documentation in the early stages of product development’. en. In: *Proceedings of the Design Society* 1 (Aug. 2021). Publisher: Cambridge University Press, pp. 3159–3168. DOI: [10.1017/pds.2021.577](https://doi.org/10.1017/pds.2021.577) (cit. on pp. 37, 40–44, 76).
- [122] Jacob T. Stanley and H. J. Lewandowski. ‘Lab notebooks as scientific communication: Investigating development from undergraduate courses to graduate research’. en. In: *Physical Review Physics Education Research* 12.2 (Sept. 2016). Publisher: American Physical Society, p. 020129. DOI: [10.1103/PhysRevPhysEducRes.12.020129](https://doi.org/10.1103/PhysRevPhysEducRes.12.020129) (cit. on p. 123).
- [123] Aurélien Tabard et al. ‘The eLabBench: an interactive tabletop system for the biology laboratory’. en. In: *Proceedings of the ACM International Conference on Interactive Tabletops and Surfaces - ITS ’11*. Kobe, Japan: ACM Press, 2011, p. 202. DOI: [10.1145/2076354.2076391](https://doi.org/10.1145/2076354.2076391) (cit. on pp. 71, 123).
- [124] Joshua G. Tanenbaum et al. ‘Democratizing technology: pleasure, utility and expressiveness in DIY and maker practice’. In: *Proceedings of the SIGCHI Conference on Human Factors in Computing Systems*. CHI ’13. New York, NY, USA: Association for Computing Machinery, Apr. 2013, pp. 2603–2612. DOI: [10.1145/2470654.2481360](https://doi.org/10.1145/2470654.2481360) (cit. on p. 117).
- [125] Nick Taylor, Ursula Hurley and Philip Connolly. ‘Making Community: The Wider Role of Makerspaces in Public Life’. en. In: *Proceedings of the 2016 CHI Conference on Human Factors in Computing Systems - CHI ’16*. Santa Clara, California, USA: ACM Press, 2016, pp. 1415–1425. DOI: [10/gdtm3r](https://doi.org/10/gdtm3r) (cit. on pp. 20, 26).
- [126] Thomas Thwaites. *The Toaster Project: Or a Heroic Attempt to Build a Simple Electric Appliance from Scratch*. Princeton Architectural Press, 2011 (cit. on p. 1).
- [127] Maryam Tohidi et al. ‘Getting the Right Design and the Design Right’. In: *Proceedings of the SIGCHI Conference on Human Factors in Computing Systems*. New York, NY, USA: Association for Computing Machinery, 2006, pp. 1243–1252 (cit. on pp. 90, 91, 124).
- [128] Iremnur Tokac et al. ‘Fabrication grammars: bridging design and robotics to control emergent material expressions’. In: *Construction Robotics* 5.1 (2021). Publisher: Springer, pp. 35–48. DOI: [10.1007/s41693-021-00053-0](https://doi.org/10.1007/s41693-021-00053-0) (cit. on p. 130).

- [129] Austin Toombs, Shaowen Bardzell and Jeffrey Bardzell. 'Becoming Makers: Hackerspace Member Habits, Values, and Identities'. en. In: *Journal Of Peer Production* 5 (2014), p. 24 (cit. on p. 116).
- [130] Austin L. Toombs, Shaowen Bardzell and Jeffrey Bardzell. 'The Proper Care and Feeding of Hackerspaces: Care Ethics and Cultures of Making'. In: *Proceedings of the 33rd Annual ACM Conference on Human Factors in Computing Systems*. New York, NY, USA: Association for Computing Machinery, Apr. 2015, pp. 629–638 (cit. on pp. 20, 26, 116).
- [131] Cristen Torrey, Elizabeth F. Churchill and David W. McDonald. 'Learning how: the search for craft knowledge on the internet'. en. In: *Proceedings of the 27th international conference on Human factors in computing systems - CHI 09*. Boston, MA, USA: ACM Press, 2009, p. 1371. DOI: [10.1145/1518701.1518908](https://doi.org/10.1145/1518701.1518908) (cit. on pp. 29, 30, 37, 43, 44).
- [132] Cristen Torrey et al. 'How-To pages: Informal systems of expertise sharing'. en. In: *ECSCW 2007*. Ed. by Liam J. Bannon et al. London: Springer London, 2007, pp. 391–410. DOI: [10.1007/978-1-84800-031-5_21](https://doi.org/10.1007/978-1-84800-031-5_21) (cit. on pp. 27–29, 37, 40, 41, 43, 44, 70).
- [133] Jasper Tran O'Leary, Khang Lee and Nadya Peek. 'A Grammar of Digital Fabrication Machines'. en. In: *Extended Abstracts of the 2021 CHI Conference on Human Factors in Computing Systems*. Yokohama Japan: ACM, May 2021, pp. 1–6. DOI: [10.1145/3411763.3451829](https://doi.org/10.1145/3411763.3451829) (cit. on p. 130).
- [134] Peter Troxler and Harmen Zipp. 'A Next Step Towards FabML: A narrative for knowledge sharing use cases in Fab Labs'. en. In: *International Fab Lab Association, the 9th International Fab Lab Conference, Fab9*. Vol. 9. Yokohama, Japan: Citeseer, 2013, p. 11 (cit. on pp. 71, 130).
- [135] Tiffany Tseng. 'Making Make-throughs: Supporting Young Makers Sharing Design Process'. en. In: *Conference on Creativity and Fabrication in Education - Fablearn '15*. Stanford, CA, USA: MIT, 2015, p. 8 (cit. on pp. 17, 28, 37, 42, 43, 47, 52–55, 74, 92).
- [136] Tiffany Tseng. 'Spin: A photography turntable system for creating animated documentation'. en. In: *Proceedings of the 14th International Conference on Interaction Design and Children - IDC '15*. Boston, Massachusetts: ACM Press, 2015, pp. 422–425. DOI: [10.1145/2771839.2771869](https://doi.org/10.1145/2771839.2771869) (cit. on pp. 73, 74, 76, 78, 82).
- [137] Tiffany Tseng, Robert Hemsley and Mitchel Resnick. 'Replay: a self-documenting construction kit'. en. In: *Proceedings of the 11th International Conference on Interaction Design and Children*. IDC '12. New York, NY, USA: Association for Computing Machinery, June 2012, pp. 320–322. DOI: [10.1145/2307096.2307156](https://doi.org/10.1145/2307096.2307156) (cit. on p. 126).

- [138] Tiffany Tseng and Mitchel Resnick. ‘Product versus process: representing and appropriating DIY projects online’. en. In: *Proceedings of the 2014 conference on Designing interactive systems - DIS '14*. Vancouver, BC, Canada: ACM Press, 2014, pp. 425–428. DOI: [10.1145/2598510.2598540](https://doi.org/10.1145/2598510.2598540) (cit. on pp. 2, 28, 29, 37, 39–43, 45, 53, 59, 70, 74, 84, 112).
- [139] Tiffany Tseng and Mitchel Resnick. ‘Spin: Examining the Role of Engagement, Integration, and Modularity in Supporting Youth Creating Documentation’. en. In: *Proceedings of the 2016 ACM Conference on Designing Interactive Systems*. DIS '16. event-place: Brisbane, QLD, Australia. New York, NY, USA: Association for Computing Machinery, June 2016, pp. 996–1007. DOI: [10.1145/2901790.2901868](https://doi.org/10.1145/2901790.2901868) (cit. on pp. 37, 42, 44, 50, 52–55, 59, 60).
- [140] Koji Tsukada et al. ‘FabNavi: Support system to assemble physical objects using visual instructions’. en. In: *Paper presented at Fab10 2* (July 2014), p. 10 (cit. on pp. 50, 52–55, 73, 75, 76, 78, 82, 85).
- [141] Katja Vilhunen, Sinikka Hannele Pöllänen and Harri Pitkaniemi. ‘Reasons for knitting blogging and its importance for crafting’. en. In: *Techne serien - Forskning i slöjdpedagogik och slöjdvetsenskap* 21.3 (June 2021), pp. 48–62. DOI: [10.7577/TechneA.4185](https://doi.org/10.7577/TechneA.4185) (cit. on p. 29).
- [142] Francesco Vitale, William Odom and Joanna McGrenere. ‘Keeping and Discarding Personal Data: Exploring a Design Space’. In: *Proceedings of the 2019 on Designing Interactive Systems Conference*. DIS '19. New York, NY, USA: Association for Computing Machinery, June 2019, pp. 1463–1477. DOI: [10.1145/3322276.3322300](https://doi.org/10.1145/3322276.3322300) (cit. on pp. 91, 115).
- [143] Shirin Vossoughi and Bronwyn Bevan. *Making and Tinkering: A Review of the Literature*. en. 2014 (cit. on p. 20).
- [144] Ron Wakkary et al. ‘Tutorial Authorship and Hybrid Designers: The Joy (and Frustration) of DIY Tutorials’. en. In: *Proceedings of the 33rd Annual ACM Conference on Human Factors in Computing Systems*. CHI '15. New York, NY, USA: Association for Computing Machinery, Apr. 2015, pp. 609–618. DOI: [10.1145/2702123.2702550](https://doi.org/10.1145/2702123.2702550) (cit. on pp. 37, 41, 42, 70, 71, 74).
- [145] Etienne Wenger. *Communities of Practice: Learning, Meaning, and Identity*. en. ISBN: 9780511803932 Publisher: Cambridge University Press. July 1998. DOI: [10.1017/CB09780511803932](https://doi.org/10.1017/CB09780511803932) (cit. on p. 2).
- [146] Matt Whitlock et al. ‘AuthAR: Concurrent Authoring of Tutorials for AR Assembly Guidance’. en. In: *Proceedings of Graphics Interface 2020*. GI 2020. University of Toronto: Canadian Human-Computer Communications Society / Société canadienne du dialogue humain-machine, 2020, pp. 431–439. DOI: [10.20380/GI2020.43](https://doi.org/10.20380/GI2020.43) (cit. on pp. 74, 75, 126).

- [147] Vincent Wilczynski. 'Academic Maker Spaces and Engineering Design'. en. In: *2015 ASEE Annual Conference and Exposition Proceedings*. Seattle, Washington: ASEE Conferences, June 2015, pp. 26.138.1–26.138.19. DOI: [10.18260/p.23477](https://doi.org/10.18260/p.23477) (cit. on p. 16).
- [148] Michael Björn Winkler et al. 'Automatic Camera Control for Tracking a Presenter during a Talk'. In: *2012 IEEE International Symposium on Multimedia*. Irvine, CA, USA: IEEE, 2012, pp. 471–476. DOI: [10/gn934v](https://doi.org/10/gn934v) (cit. on p. 77).
- [149] Jacob O. Wobbrock and Julie A. Kientz. 'Research contributions in human-computer interaction'. In: *Interactions* 23.3 (Apr. 2016), pp. 38–44. DOI: [10.1145/2907069](https://doi.org/10.1145/2907069) (cit. on p. 5).
- [150] Patricia Wolf and Peter Troxler. 'Look Who's Acting!: Applying Actor Network Theory for Studying Knowledge Sharing in a Co-Design Project'. en. In: *International Journal of Actor-Network Theory and Technological Innovation (IJANTTI)*, 7(3) 7 (2015), pp. 15–33. DOI: [10.4018/IJANTTI.2015070102](https://doi.org/10.4018/IJANTTI.2015070102) (cit. on pp. 37, 40, 44).
- [151] Patricia Wolf et al. 'Sharing is Sparing: Open Knowledge Sharing in Fab Labs'. en. In: *Journal of peer production* 5.1 (2014), p. 11 (cit. on pp. 2, 27, 37, 40, 42–44, 74, 112, 117).
- [152] M. Yang. 'A study on the comparison and inspiration for operation mode of the maker space brand in China and America'. In: *Lecture Notes in Computer Science (including subseries Lecture Notes in Artificial Intelligence and Lecture Notes in Bioinformatics)*. Vol. 9741. Type: Conference Paper. 2016, pp. 316–325. DOI: [10.1007/978-3-319-40093-8_32](https://doi.org/10.1007/978-3-319-40093-8_32) (cit. on p. 16).
- [153] D. A. Zakoldaev et al. 'The life cycle of technical documentation in the smart factory of Industry 4.0'. en. In: *IOP Conference Series: Materials Science and Engineering* 665.1 (Oct. 2019). Publisher: IOP Publishing, p. 012016. DOI: [10.1088/1757-899X/665/1/012016](https://doi.org/10.1088/1757-899X/665/1/012016) (cit. on p. 123).
- [154] Ce Zhang and Jianming Yang. *A History of Mechanical Engineering*. en. Singapore: Springer Singapore, 2020 (cit. on pp. 10, 14).

Implementing Capush

A.

There are many different ways to reify the Capush design concept into functional prototypes. Overall, the specific choices heavily depend on one's principles and constraints: For example, for maker spaces with extremely limited resources it might be important to find a frugal solution; others might value ecologically responsible choices most and may want to upcycle otherwise obsolete materials; other places might consider capture quality as the most important property.

For our own proof of concept implementations ¹, our guiding decision criterion was that the used material should be rather *low cost and easily available* to a large range of different maker spaces, even if only modest resources are at hand. We implemented proof-of-concept prototypes for the fixed, pan-tilt, clamp, and table bot concepts to explore the feasibility of the desired functionality and of our design concept overall. All our prototypes are based on Raspberry PI boards as they have a small form factor and are often readily available in fabrication workshops.

Table A.1 provides a summary of how we implemented various features of Capush and limitations we observed.

In principle, any camera accessible via network could be used as a fixed camera unit. For example, upcycling otherwise obsolete smartphone models or the use of GoPro cameras would result in higher quality footage than the above approach. The concrete choice affects, however, the extendability of the unit type: extensions based on GoPro or smartphones are likely limited to physical appendages permitting to attach it in various places whereas units built on top of a microcontroller provide more avenues for new features or the automation of features. A property which can be automated and which we explored in our study is view point control. Both manual and

1: Bill of material and current state of implementation are available on <https://af-fab-le.github.io/capush>

Table A.1.: Overview of our proof of concept implementations sorted by feature.

Feature	Description	Implementa- tion	Limitations of our ap- proach	Units types
Networked camera	Camera accessible via local wifi	Raspberry Pi3b+ w/ camera module V2	Size of the Raspberry PI reduces easy manipulation + alternatives exist	all
Mobility	Portable power supply	RPi UPSPack V3	Limited autonomy	Clamp camera
Pan/tilt assembly	Mechanism to adjust the camera viewpoint	Pan/tilt with 2 servos	Active servos limit manual ma- nipulation while active	Pan-tilt camera, clamp camera, table bot, (head-mounted camera)
Clamp	Attachment mechanism	clamps with strong springs and a hole to attach a unit	Opening and spring strength limit where it can be attached	Clamp camera
Locomotion	Robotic base to enable locomotion	Alphabot V2	Low camera viewpoint, limited autonomy	Table bot
Tool tracking	Cameras follows a tool or object around	Color tracking with OpenCV + colored dot on tool	Marker needs to remain in all frame; requires constant lighting	all pan/tilt assembly with
Location recognition	Cameras localise themselves	Fiducial markers associated to location or machine	Sufficiently sized fiducials required throughout the space	Clamp, head-mounted camera, table bot

automatic control require some form of user interface though to indicate where the camera should point or tell an automated control what to keep in the field of view. Depending on the level of indirection [14] and the desired automation, different control interfaces are possible, much of which have already been explored in previous work for both manual [52] and mixed control [9]. With our proof-of-concept prototype, we tested a basic implementation of the automatic tracking mode mentioned in the study and the video shown to respondents. It is based on color detection using OpenCV² which enables tool tracking as long as a colored dot is attached to the tool and visible in the camera image. More advanced tracking, including tool detection based on the appearance of the tool, is beyond the aims of our proof-of-concept but

²: <https://opencv.org/>

might be feasible based on results from previous work [23].

A major concern with automatic viewpoint control is that the camera image may move excessively and thus require some mechanism to stabilise the image which can be done programmatically (*e.g.*, [9]) or through a physical stabiliser unit. Unstable footage is also one of the reasons for which we did not realise a prototype for the head-mounted unit type. Previous work already explored capturing using head-worn Google glass and observed that the resulting footage risks being unstable and of low quality [26]. Thus, an image stabiliser unit, such as a gimbal pan/tilt unit, would be necessary to address the issue and achieve smooth footage. A usable prototype combining these features would require a high degree of miniaturisation to be portable on one's head so as to not disturb makers while working on their projects. While this is a promising avenue for future work, realising such a prototype goes beyond the scope of our proof of concept implementations which focused on exploring low cost implementations based on easily available material.

Asking ChatGPT for fabrication tips **B.**

I present here some examples of questions asked to ChatGPT (GPT4) about fabrication techniques. The idea is both to show how a chatbot interface could be used as a one-off resource for makers' work, but more importantly to illustrate the possibilities of the underlying machine learning algorithms. If these algorithms could be trained by the users themselves around their projects, they could generate information both specific to the project, but also general to the practice.

Show me how to use a soldering iron

Sure, I can provide you with a step-by-step guide on how to use a soldering iron:

1. Gather your tools: You'll need a soldering iron, solder, soldering stand, wire cutters, and safety glasses.
2. Set up your workspace: Choose a well-ventilated area, and make sure you have a stable surface to work on. Plug in your soldering iron and let it heat up. The ideal temperature for most soldering jobs is between 350°C to 400°C (662°F to 752°F), but this can vary depending on the type of solder and materials you are using.
3. Clean the soldering iron tip: Use a damp sponge to clean the tip of the soldering iron. This will help remove any dirt or oxidation, and ensure that the solder will adhere properly.
4. Cut the wire: Use wire cutters to trim the wire to the desired length. Strip off about 1/2 inch of insulation from the end of the wire using a wire stripper.
5. Apply flux: Apply a small amount of flux to the exposed wire. Flux is a material that helps the solder flow and bond to the wire.
6. Heat the wire: Hold the soldering iron tip against the wire and apply gentle pressure. The heat will melt the

solder, which will then flow onto the wire.

7. Apply solder: Once the wire is heated up, touch the solder to the wire. The solder should melt and flow onto the wire. Be careful not to use too much solder, as this can cause a "cold joint" that will not bond properly.
8. Let the solder cool: Allow the solder to cool for a few seconds. Do not move the wire while the solder is cooling, as this can cause the joint to weaken.
9. Inspect the joint: Once the solder has cooled, inspect the joint to ensure that it is strong and the wire is securely attached.
10. Clean up: Turn off the soldering iron and allow it to cool. Clean the tip of the soldering iron again with a damp sponge. Store your tools in a safe place.

It's important to note that using a soldering iron can be dangerous if proper safety precautions are not taken. Always wear safety glasses to protect your eyes, and make sure to use the soldering iron in a well-ventilated area. Keep the iron away from flammable materials and never touch the tip of the iron while it is hot.

Can you now explain how to build a chair?

Sure, building a chair can be a challenging but rewarding project. Here is a general guide on how to build a chair:

Materials you will need:

- ▶ Lumber (for the seat, backrest, legs, and support)
- ▶ Wood glue
- ▶ Screws or nails
- ▶ Sandpaper
- ▶ Paint or stain (optional)

Tools you will need:

- ▶ Circular saw or handsaw
- ▶ Miter saw or jigsaw
- ▶ Drill with bits and screws
- ▶ Hammer or nail gun
- ▶ Clamps
- ▶ Wood chisels
- ▶ Wood rasp

Step 1: Design the chair Before you start building, you should have a clear idea of what your chair will look like. You can find plans online, or design your own. Consider the size, shape, and style of your chair.

Step 2: Cut the lumber Using a circular saw or handsaw, cut the lumber to the appropriate lengths and angles. Use a miter saw or jigsaw to make angled cuts for the legs and backrest. Use a wood chisel or rasp to smooth any rough edges.

Step 3: Assemble the seat Using wood glue and screws or nails, assemble the seat by attaching the legs to the seat boards. Use clamps to hold the pieces in place while the glue dries. You may need to add support pieces under the seat boards to make the chair sturdier.

Step 4: Build the backrest Attach the backrest to the chair using wood glue and screws or nails. The backrest can be attached directly to the legs or to support pieces that you attach to the legs.

Step 5: Sand and finish Sand the entire chair with sandpaper to smooth any rough edges or surfaces. Apply paint or stain to the chair if desired. This will not only add to the chair's aesthetics but will also help protect it from the elements.

Step 6: Add cushions (optional) If you want your chair to be more comfortable, you can add cushions to the seat and backrest. You can buy cushions or make your own.

Building a chair requires a lot of attention to detail and can be time-consuming. It's important to have the right tools and materials and take safety precautions while working with power tools. You can modify these steps based on your specific design and needs.

What are the risks of building a chair?

Building a chair, like any woodworking project, carries some risks. Here are some potential risks to consider:

1. **Power tool injuries:** Using power tools such as saws, drills, and nail guns can be dangerous if not used properly. It's important to read the user manual, wear appropriate safety gear, and follow safety guidelines to avoid injuries.

2. Sharp objects: Woodworking involves using sharp tools like chisels and hand saws, which can cause cuts or other injuries if not used carefully.
3. Splinters: Handling rough or unfinished wood can result in splinters, which can be painful and cause infections if not properly treated.
4. Chemical exposure: Woodworking often involves the use of chemicals like wood stains, paints, and glues, which can be hazardous if not used in a well-ventilated area or with proper safety gear.
5. Structural integrity: Poorly constructed chairs can collapse or break, potentially causing injury to the user.
6. Fire hazards: Using power tools, paints, and stains can create sparks or flammable vapors, which can cause fires if proper precautions are not taken.

It's important to take necessary precautions to minimize these risks when building a chair or any other woodworking project. Wear appropriate safety gear, work in a well-ventilated area, follow the manufacturer's instructions for all tools and chemicals, and make sure the chair is structurally sound before using it.

What are the advantages of building a chair?

Building a chair can have many advantages, such as:

1. Customization: When you build a chair, you have complete control over the design, size, and materials used. This means you can create a chair that is unique and tailored to your specific needs and preferences.
2. Quality: When you build a chair, you can use high-quality materials and ensure that it is constructed with care and attention to detail. This can result in a chair that is more durable and longer-lasting than a mass-produced chair.
3. Satisfaction: Building a chair can be a rewarding experience, both in terms of the satisfaction of creating something with your own hands and in using the chair you built in your home.
4. Cost savings: Building a chair can be a cost-effective alternative to purchasing a chair from a store, especially if you have access to low-cost or salvaged materials and tools.

5. Skill development: Building a chair can help you develop your woodworking skills, such as using power tools, reading plans and blueprints, and assembling and finishing furniture. These skills can be useful for future projects and home repairs.
6. Environmentally friendly: Building a chair can be an environmentally friendly option, especially if you use salvaged or reclaimed wood. It can also reduce the environmental impact of shipping and manufacturing associated with mass-produced furniture.

Overall, building a chair can be a satisfying and rewarding experience, with the added benefits of customization, quality, cost savings, and skill development.

What should I do to document my work?

Documenting your work is important to keep track of your progress and to share your work with others. Here are some steps you can take to document your work:

1. Take photos: Take photos of your work at different stages of completion. This will help you keep track of your progress and can also be used to create a visual record of your work.
2. Keep a journal: Write down your thoughts, ideas, and progress in a journal or notebook. This can help you remember what you did and what you learned, and can be a helpful reference for future projects.
3. Record videos: If you're working on a project that involves movement, such as a robotics project, record videos to show how it works. This can be especially useful if you're trying to troubleshoot or explain your work to others.
4. Create diagrams and schematics: If you're working on a project that involves electronics or circuitry, create diagrams and schematics to document your work. This can help you remember how the circuit was designed and can be helpful if you need to make changes or repairs in the future.
5. Use version control software: If you're working on a software project, use version control software such as Git to keep track of changes and document your work. This can help you collaborate with others and can be

helpful if you need to roll back changes or troubleshoot issues.

6. Share your work: Once you've documented your work, share it with others. This can be a great way to get feedback, collaborate with others, and inspire others with your work.

Remember, documenting your work is an ongoing process that can help you stay organized and share your work with others. By taking the time to document your work, you can create a record of your progress and inspire others with your creativity and ingenuity.

How should I create a tutorial about building a chair?

Creating a tutorial about building a chair can be a great way to share your knowledge and help others learn a new skill. Here are some steps you can take to create an effective tutorial:

1. Plan your tutorial: Before you start creating your tutorial, plan out the steps you'll need to take to build the chair. Make a list of the tools and materials you'll need, and create a detailed outline of each step in the process.
2. Write out the steps: Once you've planned out your tutorial, write out each step in detail. Be sure to include any tips or tricks you've learned along the way, and provide clear and concise instructions that are easy to follow.
3. Take photos or videos: To make your tutorial more engaging and easy to follow, take photos or videos of each step in the process. This can help your readers or viewers see exactly what they need to do and how to do it.
4. Edit your tutorial: Once you've written out the steps and taken photos or videos, edit your tutorial to make sure it's clear and easy to understand. Look for any areas where you can simplify the instructions, and make sure all of the steps are in the correct order.
5. Test your tutorial: Before you publish your tutorial, test it out to make sure it works as intended. Build a chair using your tutorial to make sure that all of the steps are accurate and that there are no missing details.

6. Publish your tutorial: Once you're happy with your tutorial, publish it on a platform where others can access it. You can share it on your own website or blog, or post it on a platform like YouTube or Instructables.

Remember, creating a tutorial can take time and effort, but it can be a rewarding way to share your knowledge and help others learn a new skill. By following these steps, you can create a tutorial that is clear, easy to follow, and helpful for others who want to build a chair.

Describe me how to build a reverb pedal made of metal and wood with FreeCAD and a CNC

Building a reverb pedal with FreeCAD and a CNC involves several steps. Here's a general guide to get started:

1. Design the pedal enclosure: First, create a design for the pedal enclosure in FreeCAD. This can involve creating a 3D model of the enclosure using the software's tools. The enclosure can be made of metal and wood, so you may need to create separate models for each material.
2. Prepare the CNC: Once you've created your design, you'll need to prepare your CNC machine to cut the parts. This involves setting up the machine with the right tools and materials, and programming it to follow the design you created in FreeCAD.
3. Cut the parts: Once your CNC machine is set up, you can start cutting the parts for the pedal enclosure. This involves following the programming you created in FreeCAD and cutting the metal and wood parts to the appropriate size and shape.
4. Assemble the pedal: Once you have all of the parts cut, you can begin assembling the pedal. This involves attaching the metal and wood parts together using screws or other fasteners, and installing the reverb circuitry and other components inside the enclosure.
5. Test the pedal: Once the pedal is assembled, you can test it to make sure it works as intended. This involves connecting it to a guitar amplifier and testing the reverb effect to ensure that it sounds the way you want it to.
6. Finish the pedal: Finally, you can finish the pedal by sanding and painting the enclosure, or applying other finishes to give it a polished look.

Note that this is a general guide, and there may be specific steps involved in building a reverb pedal that are not covered here. Additionally, FreeCAD and CNC machines can be complex tools, so it may be helpful to have some experience using them before attempting this project.

How can I build a reverb circuitry ?

Building a reverb circuitry can be a fun and rewarding project for electronics enthusiasts. Here's a general guide on how to build a simple reverb circuitry:

1. Gather your materials: To build a reverb circuit, you'll need a few basic components, including a spring reverb tank, an op-amp, resistors, capacitors, and a power source. You may also need a printed circuit board (PCB) or a breadboard to assemble the circuit.
2. Connect the spring reverb tank: Start by connecting the spring reverb tank to the circuit. The tank should have input and output jacks that you can connect to the circuit using wires. Be sure to follow the manufacturer's instructions for wiring the tank correctly.
3. Assemble the op-amp circuit: Next, assemble the op-amp circuit. This involves connecting the op-amp to resistors and capacitors to create a feedback loop that generates the reverb effect. You can find schematics for reverb circuits online, or design your own using software like LTSpice.
4. Connect the op-amp to the reverb tank: Once you've assembled the op-amp circuit, you can connect it to the spring reverb tank. This involves connecting the output of the op-amp to the input of the tank, and vice versa. Again, be sure to follow the manufacturer's instructions for wiring the tank correctly.
5. Connect the power source: Finally, connect the power source to the circuit to power the op-amp and other components. You can use a battery or a DC power supply, depending on the voltage requirements of the circuit.
6. Test the circuit: Once the circuit is assembled and powered, you can test it to make sure it works as intended. Connect an audio source to the input of the circuit, and listen for the reverb effect at the output. You may need

to adjust the settings on the op-amp or reverb tank to get the desired sound.

Note that this is a general guide, and there may be specific steps involved in building a reverb circuit that are not covered here. Additionally, building electronic circuits can be complex and potentially dangerous, so it's important to take proper safety precautions and have some experience with electronics before attempting this project.